

# SERIES 7800

## Check Valves

For use in Grooved-End Piping Systems

The Gruvlok Series 7800 Check Valve is a compact, cost effective valve offering low pressure-drop, non-slam performance. The Series 7800 Check Valve assembly is lighter and faster to install, and costs less than flanged and wafer valve assemblies.

In the full-open position the Series 7800 swing clapper is held tightly against the valve body, out of the flow stream, to provide maximum flow area and prevention of clapper flutter. The clapper design produces quick, non-slam closure before flow reversal can occur, while meeting FM requirements for an anti-water hammer valve rating.

Each valve is hydrostatically tested for leak tightness to 500 PSI. The clapper-seat design permits leak free sealing of back pressures in service conditions ranging from 300 PSI (20.7 bar) to as low as 1 PSI (0.07 bar) (28" water head).



### PERFORMANCE:

**Pressure Rating:**  
Commercial Applications - Sizes 2" thru 12" inclusive, 300 psi (20.7 bar) maximum working pressure.

## MATERIAL SPECIFICATIONS

- BODY:** Ductile iron conforming to ASTM A 536, Grade 65-45-12
- COATING:** Rust inhibiting paint on exterior and interior - color, black enamel
- CLAPPER:** 2" - 5" Type 304 or 302 stainless steel to ASTM A 167  
6" - 12" Ductile iron conforming to ASTM A 536, Grade 65-45-12
- CLAPPER FACING:**  
**Grade E EPDM:** -40° to 230°F (-40° to 110°C) Service Temperature Range  
Recommended for water service, dilute acids, alkaline, oil-free air and many chemical services.  
NOT FOR USE IN PETROLEUM SERVICES.  
**Grade T Nitrile:** -20° to 180°F (-29° to 80°C) Service Temperature Range  
Recommended for petroleum products, air with oil vapors, vegetable oils and mineral oils.  
NOT FOR USE IN HOT WATER SERVICES.
- SEAT RING:** Type 304 stainless steel to ASTM A 123, ASTM A 213, ASTM A 312 or ASTM A 269
- SPRING:** Type 302 stainless steel to ASTM A 313
- HINGE PIN:** Type 304 or 302 stainless steel to ASTM A 580
- HINGE PIN BUSHINGS:** Sintered bronze to ASTM B 438
- HINGE PIN PLUGS & DRAIN PLUGS:** Cast iron to ASTM A 126 Class A

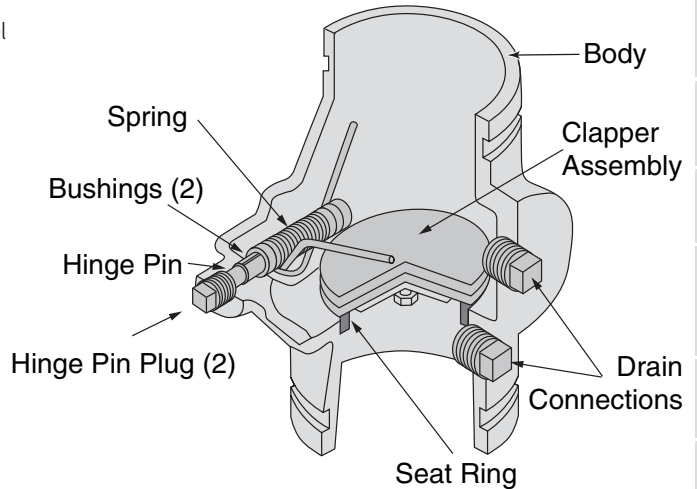

- Introduction
- Couplings
- Outlets
- Fittings
- Valves & Accessories
- High Pressure
- Advanced Copper Method (IPS)
- CTS Copper System
- DI-LOK® Nipples
- Plain-End Fittings
- HDPE Couplings
- Socket-It® Fittings
- Stainless Steel Method
- Roll Groovers
- Installation & Assembly
- Special Coatings
- Design Services
- Technical Data
- Master Format 3 Part Specs.
- Pictorial Index