

SOCK-IT® PIPING METHOD FITTINGS

FIG. 7105 - Reducing Outlet Tee (Sock-It® x Sock-It® x NPT)

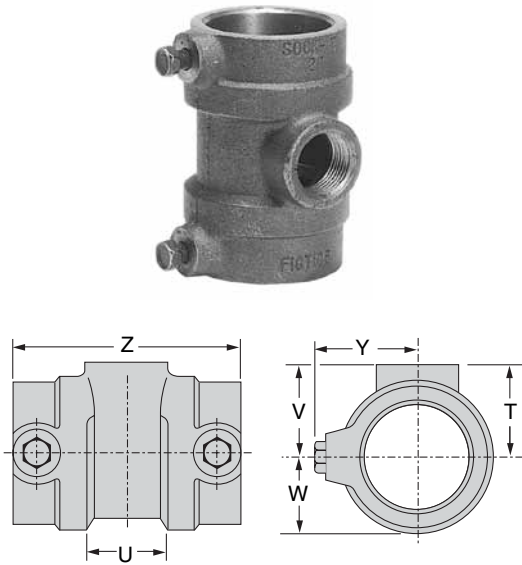

FIGURE 7105 SOCK-IT® REDUCING OUTLET TEE (S X S X NPT)									
Nominal Size	Max. Working Pressure		Dimensions						Approx. Wt. Ea.
	UL/ULC Listed	FM Approved	**T	U*	V	W	Y	Z	
In./DN(mm)	PSI/bar	PSI/bar	In./mm	In./mm	In./mm	In./mm	In./mm	In./mm	Lbs./Kg
1 x 1 x 1/2 25 x 25 x 15	300 20.7	300 20.7	1 25	1 3/8 35	1 1/16 37	1 1/16 27	1 11/16 43	4 1/4 108	2.0 0.9
1 x 1 x 3/4 25 x 25 x 20	300 20.7	300 20.7	7/8 22	1 3/8 35	1 1/16 37	1 1/16 27	1 11/16 43	4 1/4 108	1.9 0.9
1 x 1 x 1 25 x 25 x 25	300 20.7	300 20.7	7/8 22	1 3/8 35	1 1/16 37	1 1/16 27	1 11/16 43	4 1/4 108	1.9 0.9
1 1/4 x 1 1/4 x 1/2 32 x 32 x 15	300 20.7	300 20.7	1 1/8 29	1 3/8 35	1 5/8 41	1 1/4 32	1 13/16 46	4 1/4 108	2.2 1.0
1 1/4 x 1 1/4 x 3/4 32 x 32 x 20	300 20.7	300 20.7	1 25	1 3/8 35	1 5/8 41	1 1/4 32	1 13/16 46	4 1/4 108	2.2 1.0
1 1/4 x 1 1/4 x 1 32 x 32 x 25	300 20.7	300 20.7	1 25	1 3/8 35	1 5/8 41	1 1/4 32	1 13/16 46	4 1/4 108	2.0 0.9
1 1/2 x 1 1/2 x 1/2 40 x 40 x 15	300 20.7	300 20.7	1 1/4 32	1 3/8 35	1 3/4 44	1 3/8 35	1 15/16 49	4 3/8 111	2.7 1.2
1 1/2 x 1 1/2 x 3/4 40 x 40 x 20	300 20.7	300 20.7	1 1/8 29	1 3/8 35	1 3/4 44	1 3/8 35	1 15/16 49	4 3/8 111	2.6 1.2
1 1/2 x 1 1/2 x 1 40 x 40 x 25	300 20.7	300 20.7	1 1/8 29	1 3/8 35	1 3/4 44	1 3/8 35	1 15/16 49	4 3/8 111	2.5 1.1
2 x 2 x 1/2 50 x 50 x 15	175 12.1	250 17.2	1 1/2 38	1 3/8 35	1 15/16 49	1 5/8 41	2 3/16 56	4 3/4 121	3.5 1.6
2 x 2 x 3/4 50 x 50 x 20	175 12.1	250 17.2	1 3/8 35	1 3/8 35	1 15/16 49	1 5/8 41	2 3/16 56	4 3/4 121	3.4 1.5
2 x 2 x 1 50 x 50 x 25	175 12.1	250 17.2	1 3/8 35	1 3/8 35	1 15/16 49	1 5/8 41	2 3/16 56	4 3/4 121	3.3 1.5
2 1/2 x 2 1/2 x 3/4 65 x 65 x 20	175 12.1	175 12.1	1 1/2 38	1 3/8 35	2 1/8 54	1 15/16 49	2 1/16 62	4 3/4 121	5.2 2.4
2 1/2 x 2 1/2 x 1 65 x 65 x 25	175 12.1	175 12.1	1 1/2 38	1 3/8 35	2 1/8 54	1 15/16 49	2 1/16 62	4 3/4 121	5.2 2.4

* "U" - Run take-out dimension.

** "T" - Outlet take-out dimension.

FIG. 7106 - Reducing Tee (Sock-It® x Sock-It® x NPT)

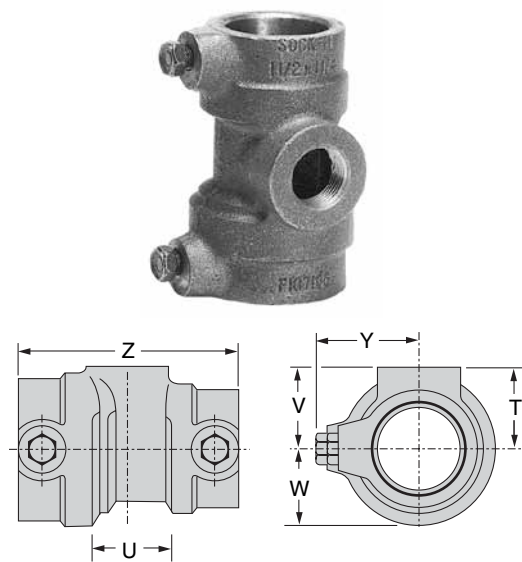

FIGURE 7106 SOCK-IT® REDUCING TEE (S x S x NPT)									
Nominal Size	Max. Working Pressure		Dimensions						Approx. Wt. Ea.
	UL/ULC Listed	FM Approved	**T	U*	V	W	Y	Z	
In./DN(mm)	PSI/bar	PSI/bar	In./mm	In./mm	In./mm	In./mm	In./mm	In./mm	Lbs./Kg
1 1/4 x 1 x 1/2 32 x 25 x 15	300 2.1	300 2.1	1 25	1 3/8 35	1 1/16 37	1 1/4 32	1 13/16 46	4 1/4 108	2.1 1.0
1 1/4 x 1 x 3/4 32 x 25 x 20	300 20.7	300 20.7	7/8 22	1 3/8 35	1 1/16 37	1 1/4 32	1 13/16 46	4 1/4 108	2.1 1.0
1 1/4 x 1 x 1 32 x 25 x 25	300 20.7	300 20.7	7/8 22	1 3/8 35	1 1/16 37	1 1/4 32	1 13/16 46	4 1/4 108	2.0 0.9
1 1/2 x 1 1/4 x 1/2 40 x 32 x 15	300 20.7	300 20.7	1 1/8 29	1 3/8 35	1 9/16 40	1 3/8 35	1 15/16 49	4 3/8 111	2.5 1.1
1 1/2 x 1 1/4 x 3/4 40 x 32 x 20	300 20.7	300 20.7	1 25	1 3/8 35	1 9/16 40	1 3/8 35	1 15/16 49	4 3/8 111	2.4 1.1
1 1/2 x 1 1/4 x 1 40 x 32 x 25	300 20.7	300 20.7	1 25	1 3/8 35	1 9/16 40	1 3/8 35	1 15/16 49	4 3/8 111	2.2 1.0
2 x 1 1/2 x 1/2 50 x 40 x 15	175 12.1	250 17.2	1 1/4 32	1 3/8 35	1 3/4 44	1 5/8 41	2 3/16 56	4 9/16 116	3.2 1.5
2 x 1 1/2 x 3/4 50 x 40 x 20	175 12.1	250 17.2	1 1/8 29	1 3/8 35	1 3/4 44	1 5/8 41	2 3/16 56	4 9/16 116	3.1 1.4
2 x 1 1/2 x 1 50 x 40 x 25	175 12.1	250 17.2	1 1/8 29	1 3/8 35	1 3/4 44	1 5/8 41	2 3/16 56	4 9/16 116	3.0 1.4

* "U" - Run take-out dimension.

** "T" - Outlet take-out dimension.