

Fig. 281

Wedge Type Concrete Insert

Size Range: $\frac{3}{8}$ " through $\frac{7}{8}$ "

Material: Carbon steel body; malleable iron nut

Finish: Plain or Galvanized

Service: Upper attachment for suspending pipe or conduit from concrete ceiling.

Approvals: Complies with Federal Specification A-A-1192A (Type 18), WW-H-171-E (Type 19), ANSI/MSS SP-69 and MSS SP-58 (Type 18). UL, ULC Listed and FM Approved (Sizes $\frac{3}{8}$ " - $\frac{3}{4}$ ").

Installation:

1. Nail insert to wooden forms.
2. Where convenient, reinforcing rods may be placed in the opening through the top of the insert, or short lengths of reinforcing rod may be wired to the insert prior to pouring concrete. However, note that the specified load ratings and approvals are not dependent on the use of any reinforcing rods in contact with the insert.
3. After concrete is poured and forms removed, insert screw driver into slot in knockout plate and snap it out.
4. The nut may be put on the rod before inserting in the insert body. Then, turn rod so that elongated nut lies across the slot; screw rod through nut until rod is firmly against the top of the recess.



Features:

- Nut may be put on hanger rod before insertion, avoiding need of locating nut in insert body prior to inserting rod.
- Insert nut, when located in position, wedges against the sloping sides of insert, providing greater support than if resting on lower edge of the insert body.
- Wedge-shaped body is so held by concrete in compression thus increasing load carrying capacity.
- Easily removed knockout plate.
- Rod can be adjusted along complete length of slot.
- One body for six sizes of rod.

Ordering: Specify figure number, name and size of nut.

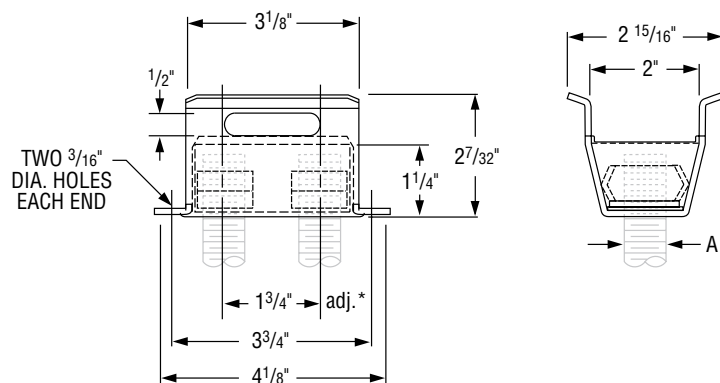

FIG. 281: LOAD (LBS) • WEIGHT (LBS) • DIMENSIONS (IN)			
	Rod Size A	Max Load ■	Weight
Insert Complete With Nut	$\frac{3}{8}$	730	0.82
	$\frac{1}{2}$	1,130	0.86
	$\frac{5}{8}$	1,200	0.89
	$\frac{3}{4}$		0.86
	$\frac{7}{8}$		0.93
Insert Only	—	—	0.69
Nut Only	$\frac{1}{4}$	—	0.13
	$\frac{3}{8}$	—	
	$\frac{1}{2}$	—	0.17
	$\frac{5}{8}$	—	0.20
	$\frac{3}{4}$	—	0.17
	$\frac{7}{8}$	—	0.24

■ Based on insert and nut only. Rating is subject to the condition that the concrete used is of sufficient strength to hold the insert.