

Fig. 199

Heavy Welded Steel Bracket

Material: Carbon steel

Finish: Plain or Galvanized

Service: Recommended for the support of loads from above or below bracket.

Approvals: Complies with Federal Specification A-A-1192A (Type 33)

WW-H-171-E (Type 34), ANSI/MSS SP-69 and MSS SP-58 (Type 33).

How to size: Determine size by dimensions most suitable to the installation (see dimensions of standard brackets below). Special welded steel brackets can be furnished on order.

Installation: When bolted to a wall, an additional back plate may be required of such thickness and size as to properly distribute the weight over the wall. Size and thickness of the back plate is governed by the load to be carried and the nature and conditions of the wall. Back plates furnished upon request.

Features: If supporting pipe by rod, rod can be installed at any point along the length of the bracket thus providing horizontal adjustment.

Ordering: Specify bracket number, figure number, name. Orders for special brackets are to be accompanied by detailed sketch.

Order Separately: Rod, Fig. 60, bolts, nuts, and back plates for fastening brackets to wall. Specify size and length of rod, bolts size, thickness, and drilling of back plates.

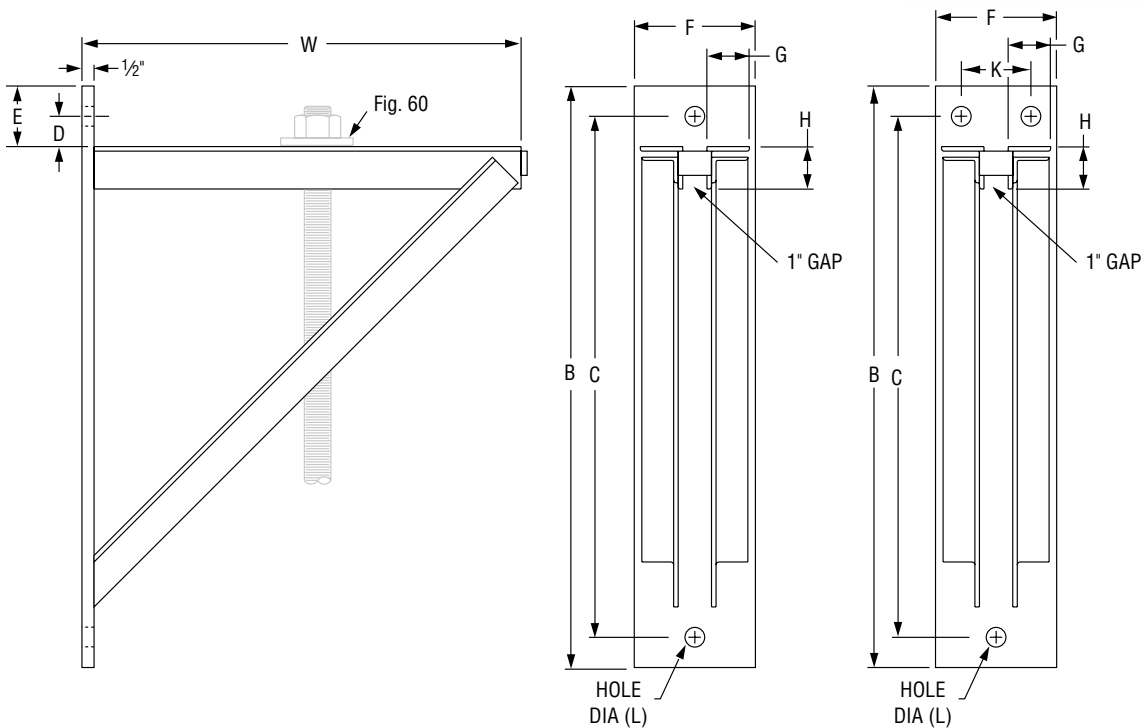
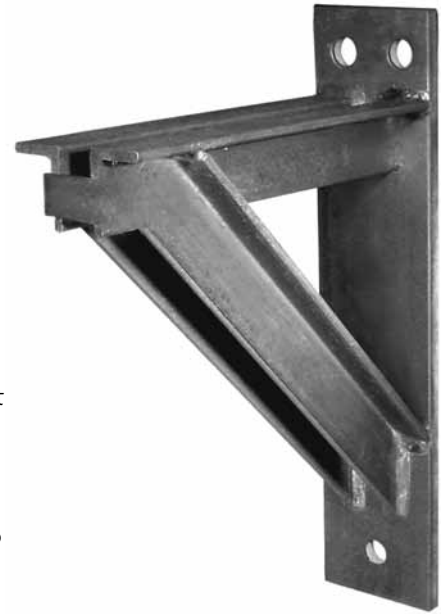

FIG. 199: LOAD (LBS) • WEIGHT (LBS) • DIMENSIONS (IN)

Bracket no.	Max Load	Weight	W	B	C	D	E	F	G	H	K	L
0	3,000	24.3	12	18	15 ¹ / ₄	1 ³ / ₈	2 ³ / ₄	4	1 ¹ / ₄	2	—	1 ³ / ₁₆
1		51.8	18	24	21 ³ / ₈	1 ⁷ / ₁₆		5	2		2 ³ / ₄	1 ⁵ / ₁₆
2		65.8	24	30	27 ¹ / ₂	1 ¹ / ₂	3	6	2 ¹ / ₂	3 ¹ / ₂	2 ¹ / ₂	1 ¹ / ₁₆
3		82.1	30	36	33 ³ / ₄	1 ⁵ / ₈						
4		140.5	36	42	39	1 ¹ / ₂						
5		166.4	42	50	46		3 ¹ / ₂					