



# AIR MAINTENANCE DEVICE MODEL H-1

## DESCRIPTION AND OPERATION

Globe's Model H-1 Air Pressure Maintenance Device is an automatic, field-adjustable device of the pressure reducing type. It is used to control the supervisory air pressure in a dry pipe sprinkler system, preaction system, or dry pilot line system of a dry pilot sprinkler actuated deluge or preaction valve. The H-1 is utilized in applications where there is a compressed air (or nitrogen) source which is at a higher pressure than the desired system pressure. Pressure sources include plant air supplies having their own automatic compressor controls, or nitrogen supplies having single-stage cylinder mounted pressure regulators.

The 1/2" globe valve is opened to admit air speedily to the dry pipe system. It is closed once the desired system air pressure has been established. As pressure drops on the system side of the 1/4" check valve, the regulator and metering orifice operate automatically to replace small losses of air which periodically occur in the system due to temperature or other system variations. The regulator and metering orifice limit the volume of air introduced to assure that the rate of air replacement is less than that from a discharging sprinkler so that system activation may take place.

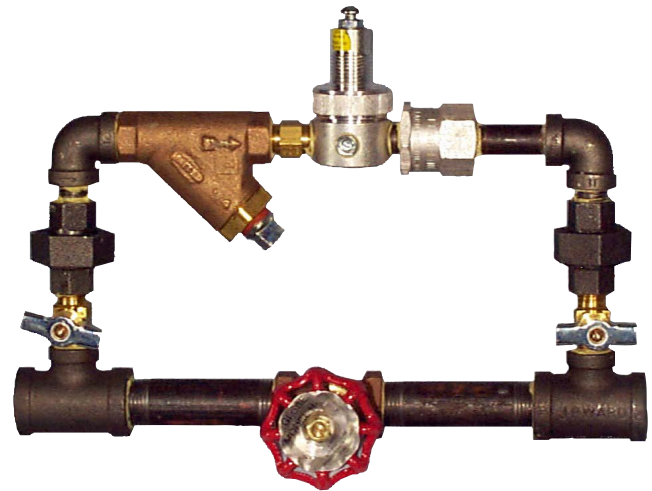

**MODEL H-1  
AIR MAINTENANCE DEVICE**

## APPROVALS

- UL Listed
- FM Approved
- NYC-DOB MEA 335-91-M

## TECHNICAL DATA

- Physical Dimensions  
9 11/16" X 7 3/4"  
(246 mm X 197 mm)

## SPECIFICATIONS

	U.S.	METRIC
PRESSURE RANGE OUTPUT	15-50 PSI	1.05-3.51 kg/cm <sup>2</sup>
PRESSURE DIFFERENTIAL	2 1/2 PSI	0.176 kg/cm <sup>2</sup>
CONNECTIONS		
FROM AIR SUPPLY	1/2" FEMALE NPT	
TO SYSTEM	1/2" FEMALE NPT	

NOTE: METRIC CONVERSIONS ARE APPROXIMATE.

# AIR MAINTENANCE DEVICE MODEL H-1

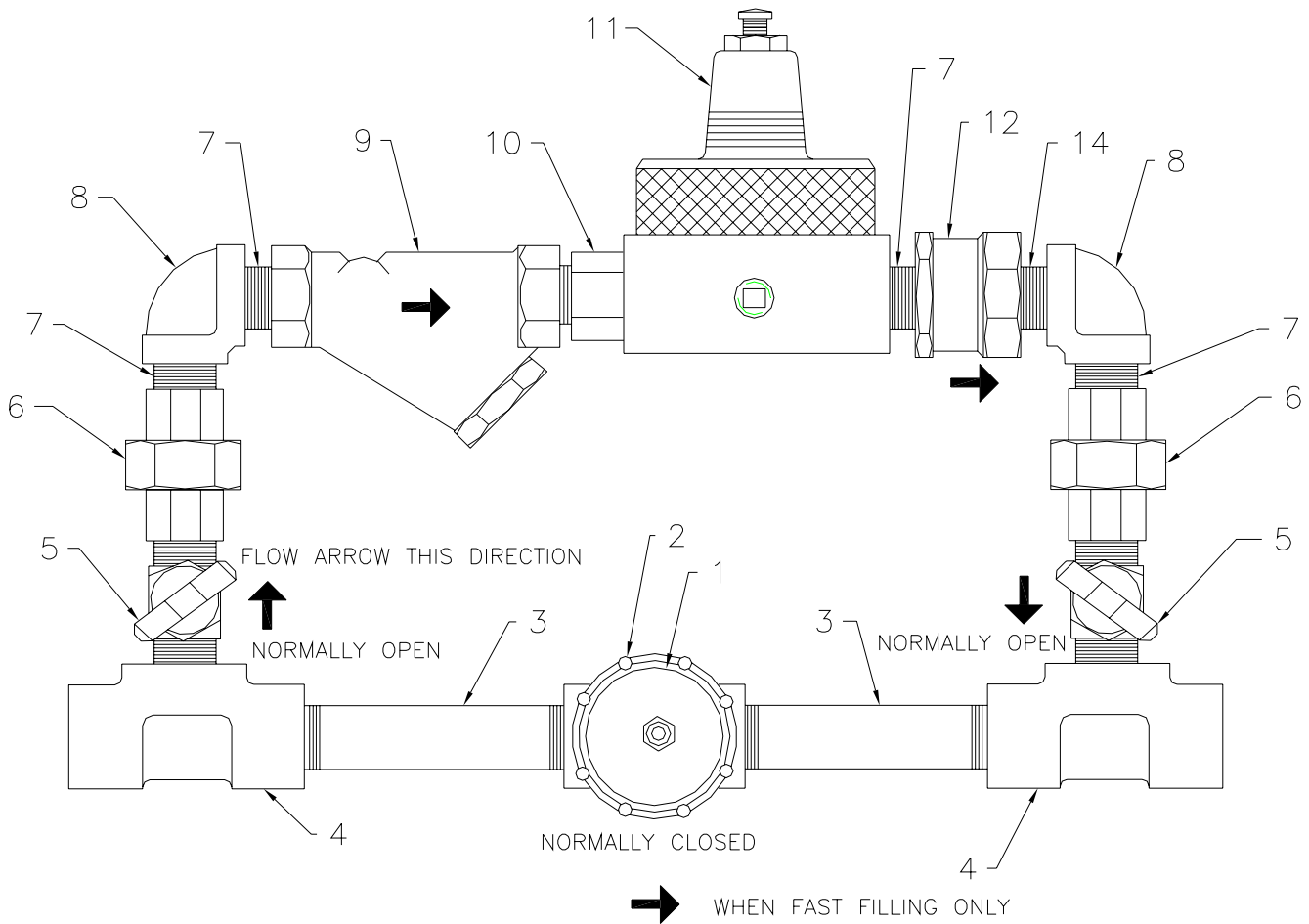

ITEM	DESCRIPTION	MAT'L	P/N	ITEM	DESCRIPTION	MAT'L	P/N
1	Name Plate	Aluminum	320592	8	1/4 Black Elbow	Steel	311201
2	1/2 Globe Valve	Brass	311601	9	1/4 Strainer	Brass	320587
3	1/2 X 3 1/2 Nipple	Steel	310305	10	Metering Orifice	Brass	320588
4	1/2 X 1/2 X 1/4 Tee	Steel	311314	11	Air Regulator	Aluminum	320590
5	1/4 Needle Valve	Brass	320586	12	1/4 Check Valve	Aluminum	320589
6	1/4 Union	Steel	311401	14	1/4 X 2 Nipple	Steel	310102
7	1/4 Close Nipple	Steel	310100				

## ORDERING INFORMATION

### SPECIFY

- Quantity • Model Number



JULY 2010

## GLOBE® PRODUCT WARRANTY

Globe agrees to repair or replace any of its own manufactured products found to be defective in material or workmanship for a period of one year from date of shipment.

For specific details of our warranty please refer to Price List Terms and Conditions of Sale (Our Price List).

4077 AIRPARK DRIVE, STANDISH, MICHIGAN 48658

989-846-4583

1-800-248-0278

FAX 989-846-9231

www.globesprinkler.com

PRINTED U.S.A.

BULLETIN H1 REV# 1