

Fig. 170

Horizontal Traveler

Size Range: Available in four sizes to take loads to 20,700 (lbs). All sizes provide for 12" of horizontal travel.

Approvals: Complies with ANSI/MSS SP-69 and MSS SP-58 (Type 58).

Features:

- Highly economical
- Minimum friction
- Virtually dust proof
- Compact – designed for minimum head room
- Versatile

Installation: Shipped ready for installation. Attach to the supporting steel by welding around the frame.

Ordering: Specify size number, figure number, name and "H" dimension, if required. Horizontal travelers will be designed for special loads, travels or dual directional travel upon request.



The Anvil Fig. 170 horizontal traveler facilitates the supporting of piping systems subject to linear horizontal movements where head room is limited. Designed for use with Anvil Variable Spring Hangers or Constant Supports it can also be used in conjunction with a rigid type hanger assembly. Refer to Fig. 71SD and 72SD for additional horizontal traveler designs.

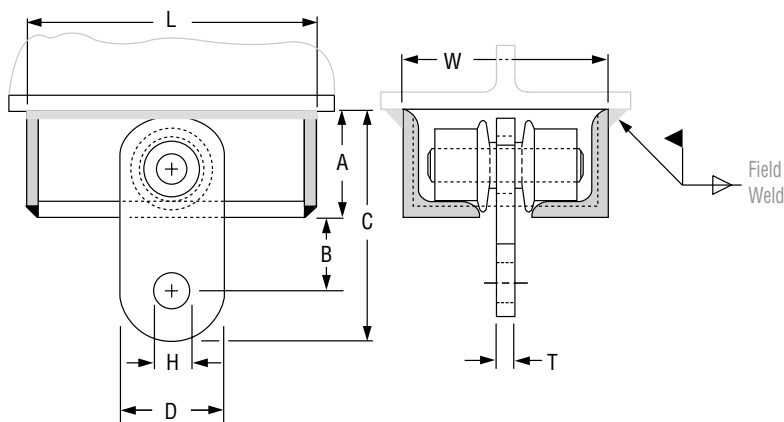

FIG. 170: LOADS (LBS) • WEIGHTS (LBS) • DIMENSIONS (IN)

Size	Maximum Load	Weight	A	B	C	D	H Max	L	T	W
1	3,770	15	2½	1⅝	5⅜	2½	1⅝	15⅝	¾	4⅝
2	6,230	37	3½	2⅝	7⅞	3½	1⅝	16⅝		6⅞
3	11,630	69	5	3	10½	5	1¾	17⅞	1	8⅞
4	20,700	102	6	3½	12½	6	2⅝	19⅞	1½	9⅞