

Electrofusion Fittings: High Volume Tapping Tees (EF HVTT)

1 1/4" Outlet

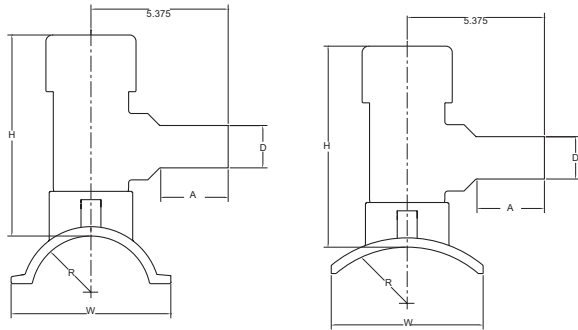

2" IPS-6" DIPS

8" IPS-12" DIPS

2" Outlet

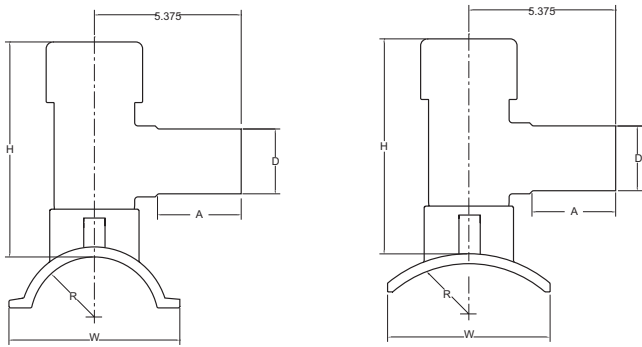

2" IPS-6" DIPS

8" IPS-12" DIPS



EF HVTT DIMENSIONS w/1 1/4" BUTT OUTLET

Size	A	W	H	D
2" IPS	2.680	3.590	6.650	1.660
3" IPS	2.680	4.600	6.660	1.660
4" IPS/DIPS	2.680	6.260	7.270	1.660
6" IPS/DIPS	2.680	8.68	8.43	1.660
8" IPS/DIPS	2.680	6.10	7.88	1.660
10" IPS/DIPS	2.680	6.10	7.88	1.660
12" IPS/DIPS	2.680	6.10	7.880	1.660

EF HVTT DIMENSIONS w/2" OUTLET

Size	A	W	H	D
2" IPS	3.000	3.590	6.65	2.600
3" IPS	3.000	4.600	6.66	2.600
4" IPS/DIPS	3.000	6.260	7.27	2.600
6" IPS/DIPS	3.000	8.680	8.43	2.600
8" IPS/DIPS	3.000	5.92	7.88	2.600
10" IPS/DIPS	3.000	6.10	7.88	2.600
12" IPS/DIPS	3.000	6.100	7.88	2.600

(PE2406/PE2708) ELECTROFUSION HIGH VOLUME TAPPING TEE

Outlet Size	Main Size	Cutter Size Material	Pin Type	Clamp Type	Part Number	Pack. Qty.	Wt.	CSA	
1 1/4" IPS	2" IPS	1.5 / Steel	4.7 R	B	5757109	10	3.32	YES	
1 1/4" IPS	3" IPS	1.5 / Steel	4.7 R	C	5757110	10	3.30	YES	
1 1/4" IPS	4" IPS	1.5 / Steel	4.7 R	D	5757111	8	3.48	YES	
1 1/4" IPS	6" IPS	1.5 / Steel	4.7 R	E	5757112	5	3.65	YES	
1 1/4" IPS	8" IPS	1.5 / Steel	4.7 R	H	5757113	10	3.45	YES	
1 1/4" IPS	12" IPS	1.8 / Steel	4.7 S	H	10009831	8	3.35	-	Low Torque Cutter
2" IPS	2" IPS	1.5 / Steel	4.7 R	B	5757114	10	3.25	YES	
2" IPS	3" IPS	1.8 / Steel	4.7 R	C	10009496	10	3.44	YES	Low Torque Cutter
2" IPS	3" IPS	1.8 / Steel	4.7 R	Underpart	10009719			-	Low Torque Cutter
2" IPS	4" IPS	1.8 / Steel	4.7 R	D	10009498	8	3.62	YES	
2" IPS	4" IPS	1.8 / Steel	4.7 R	Underpart	10009725			-	Low Torque Cutter
2" IPS	6" IPS	1.8 / Steel	4.7 R	E	10009500	5	3.83	YES	
2" IPS	6" IPS	1.8 / Steel	4.7 R	Underpart	10009731			-	Low Torque Cutter
2" IPS	8" IPS	1.8 / Steel	4.7 R	H	10009502	10	3.52	YES	
2" IPS	10" IPS	1.8 / Steel	4.7 S	H	10009518	8	6.16	-	
2" IPS	12" IPS	1.8 / Steel	4.7 S	H	10009520	8	6.16	-	

4.7R = 4.7 Pin with Resistor

4.7S = 4.7 Solid Pin

Call for availability of other sizes and dimensions.