

SOCKET CLAMPS

Fig. 600

Socket Clamp for Ductile Iron or Cast Iron Pipe

Size Range: 3" through 24" pipe

Material: Two carbon steel halfbands and two bolts and nuts.

Finish: Plain or Galvanized

Service: Clamps joints of socket fittings together to prevent distortion of pipe line under excessive water pressure.

Approvals: Complies with Federal Specification A-A-1192A (Type 8), ANSI/MSS SP-69 and MSS SP-58 (Type 8).

Features: An economical method of anchoring joints of socket fittings when used on other than fire protection work.

Ordering: Specify pipe size, figure number, name and finish.



Fig. 599

Socket Clamp Washer

Two cast iron or steel washers, Fig. 599, are used with each Fig. 600 socket clamp and these must be ordered separately.

Ordering: Specify washer size, figure number, name and finish.

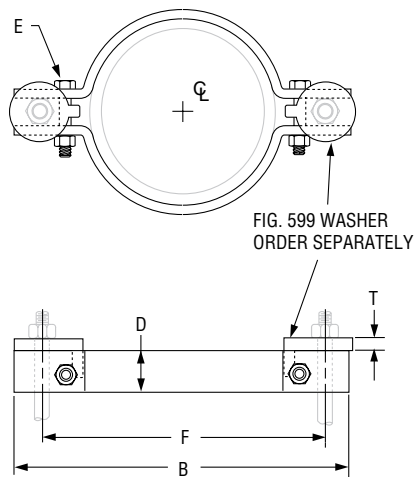

FIG. 600, FIG. 599: WEIGHT (LBS) • DIMENSIONS (IN)

D.I./C.I. Pipe Size	Weight		Pipe O.D.	B	D Width	Bolt Dia. E	F	T	Fig. 599: Washer Rod Dia.
	Fig. 600: Clamp	Fig. 599: Washer							
3	9.7	1.2	4	11 ⁵ / ₈	2	5/8	8 ⁵ / ₈	5/8	3/4
4	11.0		5	12 ¹ / ₈			9 ³ / ₄		
6	12.7		7 ¹ / ₁₆	14 ³ / ₈			12		
8	14.5		9 ³ / ₁₆	16 ⁵ / ₈			14 ¹ / ₄		
10	16.3		11 ³ / ₈	18 ⁷ / ₈			16 ¹ / ₂		
12	18.3		13 ¹ / ₂	21 ¹ / ₄			18 ³ / ₈		
14	48.7	2.7	15 ³ / ₄	25 ¹ / ₂	3	7/8	23	1 ¹ / ₈	1 ¹ / ₄
16	69.2		17 ⁷ / ₈	28	4	1	25 ¹ / ₂		
18	82.0	4.5	20	31 ¹ / ₂	4 ¹ / ₂	1 ¹ / ₄	27 ⁵ / ₈		
20	97.5		22 ¹ / ₈	33 ³ / ₄			29 ³ / ₄		
24	132.0	6.8	26 ³ / ₈	39 ³ / ₄	5	1 ¹ / ₂	35 ¹ / ₄	1 ¹ / ₄	1 ¹ / ₂