

Fig. 291

Clevis Pin with Cotters

Size Range: 1/2" through 4"

Material: Carbon steel

Finish: Plain or Galvanized

Maximum Temperature: 650° F

Service: For use with type C variable spring hanger, type C constant support (Fig. 81-H only) and Fig. 66 welded beam attachment.

Ordering: Specify pin diameter, figure number, name, finish and if cotter pins are required.

Note: The acceptability of galvanized coatings at temperatures above 450° F is at the discretion of the end user.

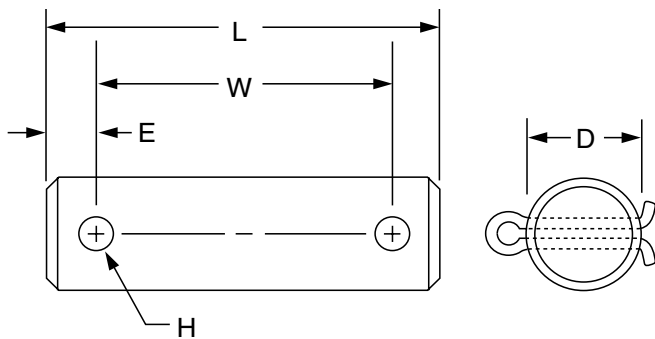

FIG. 291: LOADS (LBS) • WEIGHTS (LBS) • DIMENSIONS (IN)

Pin Dia. D	Max Load		Weight	L	W	E	H	Cotter Pin Size
	650° F	750° F						
1/2	730	572	0.12	2 7/8	2 1/8	3/8	5/32	1/8 x 1 1/4
5/8	1,350	1,057	0.18	3 1/8	2 3/8		7/32	3/16 x 1 1/2
3/4	2,160	1,691	0.29	3 5/8	2 7/8			
7/8	3,230	2,529	0.47	4	3 1/4		3/16 x 2	
1	4,480	3,508	0.67	4 3/4	4	1/2	9/32	1/4 x 2
1 1/8	5,900	4,620	1.00	5 3/8	4 3/8			
1 1/4	9,500	7,439	2.10	6	5	5/8	3/8	3/8 x 3
1 3/8	13,800	10,805	3.30	7 1/8	5 7/8			
1 1/2	18,600	14,564	4.80	7 5/8	6 3/8			3/8 x 4
1 3/4	24,600	19,262	7.20	7 7/8	6 5/8			
2	32,300	25,291	9.30	8 1/4	6 3/4	3/4	1/2	1/2 x 5
2 1/4	39,800	31,163	12.50	8 1/2	7			
2 1/2	49,400	38,680	16.60	8 3/4	7 1/4			1/2 x 6
2 3/4	60,100	47,058	20.00	9 1/2	8			
3	84,700	66,320	25.10	9 3/4	8 1/4			
3 1/4	98,500	77,125	34.80					