



**EXTENDED COVERAGE
LIGHT HAZARD AUTOMATIC
SPRINKLERS MODEL
GL8159 PENDENT TO MEET
IBC-ASCE/SEI 7 CODES FOR
SEISMIC AREAS C, D & E**

DESCRIPTION AND OPERATION

The Globe Model GL8159-EQ Extended Coverage Pendent Sprinkler for Light Hazard occupancies is a low profile yet durable design which utilizes a 5mm frangible glass ampule as the thermosensitive element. While the sprinkler provides an aesthetically pleasing appearance, it serves to protect various light hazard area coverages and should be installed in accordance with NFPA 13. This sprinkler series is available in four temperature ratings and several finishes to meet many varying design requirements.

The heart of Globe's GL Series sprinkler proven actuating assembly is a hermetically sealed frangible glass ampule that contains a precisely measured amount of fluid. When heat is absorbed, the liquid within the bulb expands increasing the internal pressure. At the prescribed temperature the internal pressure within the ampule exceeds the strength of the glass causing the glass to shatter. This results in water discharge which is distributed in an approved pattern.

The use of the 4 1/2" diameter recessed escutcheon allows for 1" of clearance around the sprinkler body, and meets the IBC-ASCE/SEI 7 requirements for use in seismic design categories C, D & E.

The sprinkler, and escutcheon are not factory assembled. Assembly is done at the time of installation.

TECHNICAL DATA

- See reverse side for Approvals and Specifications.
- Temperature Rating - 135°F (57°C), 155°F (68°C), 175°F (79°C), 200°F (93°C)
- Water Working Pressure Rating - 175 psi (12 Bars)
- Factory tested hydrostatically to 500 psi (34 Bars)
- Maximum low temperature glass bulb rating is -67°F (-55°C)
- Frame - bronze • Deflector - brass • Screw - brass
- Bulb seat - copper • Spring - nickel alloy • Seal - teflon
- Bulb - glass with glycerin solution, 5mm
- Escutcheon Assembly - steel



**EXTENDED COVERAGE PENDENT
WITH OPTIONAL 4 1/2" SEISMIC
RECESSED ESCUTCHEON**

• SPRINKLER TEMPERATURE RATING/CLASSIFICATION and COLOR CODING

CLASSIFICATION	AVAILABLE SPRINKLER TEMPERATURES		BULB COLOR	N.F.P.A. MAXIMUM CEILING TEMPERATURE	
	135°F/155°F	57°C/68°C		100°F	38°C
ORDINARY	175°F/200°F	79°C/93°C	ORANGE/RED	150°F	66°C
INTERMEDIATE			YELLOW/GREEN		

EXTENDED COVERAGE LIGHT HAZARD AUTOMATIC SPRINKLERS MODEL GL 8159 PENDENT TO MEET IBC-ASCE/SEI 7 CODES FOR SEISMIC AREAS C, D & E

SPECIFICATIONS

NOMINAL "K" FACTOR	THREAD SIZE	LENGTH	FINISHES
8.1 (116 metric)	3/4" NPT	3" (7.6 cm)	Factory Bronze *Satin Chrome Bright Chrome White Polyester+ Black Polyester+ *Lead Coated +

NOTE: METRIC CONVERSIONS ARE APPROXIMATE.

*FINISHES AVAILABLE ON SPECIAL ORDER.
+AVAILABLE AS UL LISTED CORROSION
RESISTANT WHEN SPECIFIED ON ORDER.

APPROVALS

STYLE	SIN MODEL	K FACTOR	135°F 57°C	155°F 68°C	175°F 79°C	200°F 93°C	cULus
PENDENT	GL8159	8.1	X	X	X	X	X

U.L. LISTING DESIGN - USE REQUIREMENTS FOR LIGHT HAZARDS ONLY

STYLE	TEMP.	AREA OF COVERAGE	MIN. PRESSURE P.S.I.	FLOW IN G.P.M.
RECESSED PENDENT	135°F / 57°C	16' x 16'	10.3	26
	155°F / 68°C	18' x 18'	16.6	33
	175°F / 79°C	20' x 20'	24.4	40
	200°F / 93°C			

NOTE: DUE TO THE HIGH SPRAY PATTERN CREATED BY THIS SPRINKLER, THERE MUST BE A MINIMUM SPACING OF 8'-0" BETWEEN SPRINKLERS TO ELIMINATE THE RISK OF COLD SOLDERING.

CROSS SECTION

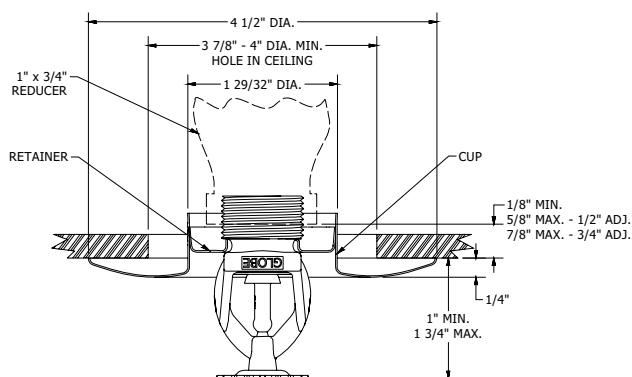

PENDENT WITH OPTIONAL IBC
SEISMIC RECESSED ESCUTCHEON

ORDERING INFORMATION

SPECIFY

- Quantity • Model Number • Style
- Orifice • Temperature • Finishes desired
- Quantity - Recessed Wrenches - P/N 325401, Rev. D
- Quantity - Protective Caps - P/N 327109-CAP (Friction Fit Recessed)

GLOBE® PRODUCT WARRANTY

Globe agrees to repair or replace any of its own manufactured products found to be defective in material or workmanship for a period of one year from date of shipment.

For specific details of our warranty, please refer to Price List Terms and Conditions of Sale (Our Price List).

