

Fig. 432

Special Clamp

Size Range: 2" through 24"

Material: Carbon steel

Finish: Plain or Galvanized

Maximum Temperature: Plain 750° F, Galvanized 450° F
for carbon steel pipe only

Service: Used with and where pipe slides cannot be welded directly to pipe or copper tube. When used with fiberglass, plastic, or aluminum pipe, a thin protective liner should be inserted between the pipe and the clamp. Clamp is designed for use with Figure 257 and Figures 436 and 439 slides and tees.

Ordering: Specify figure number, pipe size, name and finish.

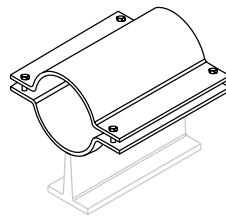

Fig. 257
w/Fig 432 Clamp

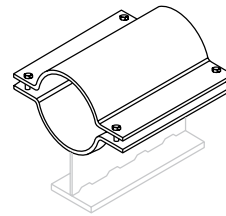

Fig. 436
w/Fig 432 Clamp

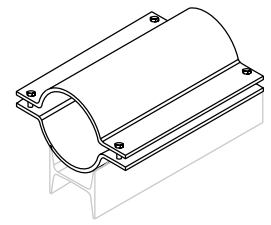

Fig. 439
w/Fig 432 Clamp

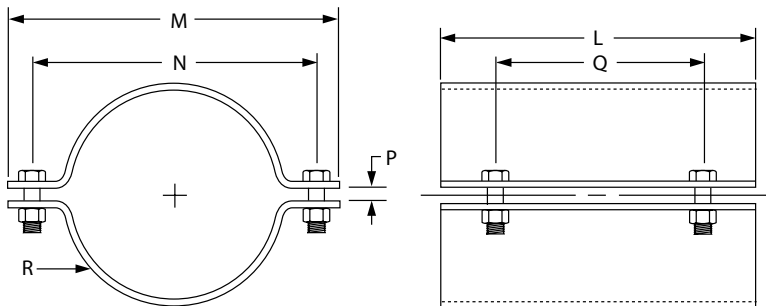

FIG. 432: WEIGHT (LBS) • DIMENSIONS (IN)

Pipe Size	L	M	N	P	Q	R Stock Size	Weight
2	6	5	4	1/4	4 1/2	1/8 x 6	2
2 1/2		5 1/2	4 1/2				3
3		6	5				3
3 1/2		6 1/2	5 1/2				4
4		7	6				4
5	8	8	7	3/8	6	3/16 x 8	5
6		9 5/8	8 1/2				12
8		11 5/8	10 1/2				15
10		13 3/4	12 5/8				18
12		15 3/4	14 5/8				21
14	12	17 7/8	16 1/2	1/2	8	1/4 x 12	41
16		19 7/8	18 1/2				46
18		21 7/8	20 1/2				52
20		23 7/8	22 1/2				57
24		28 1/8	26 7/8				67