

CLEVIS HANGERS

Fig. 260

Adjustable Clevis Hanger

Size Range: 1/2" through 30"

Material: Carbon steel

Finish: Plain, Galvanized, or Primed, also available in Plastic or Epoxy Coated

Service: Recommended for the suspension of stationary pipe lines.

Maximum Temperature: Plain 650° F, Galvanized and Epoxy 450° F

Approvals: Complies with Federal Specification A-A-1192A (Type 1), WW-H-171-E (Type 1), ANSI/MSS SP-69 and MSS SP-58 (Type 1). UL, ULC Listed and FM Approved (Sizes 3/4" through 8").

Installation: Hanger load nut above clevis must be tightened securely to assure proper hanger performance.

Adjustment: Vertical adjustment without removing pipe may be made from 3/8" through 5 1/8", varying with the size of clevis. Tighten upper nut after adjustment.

Features:

- Design has yoke on outside of lower U-strap so yoke cannot slide toward center of bolt, thus bending of bolt is minimized.
- Sizes 5" and up have rod and two nuts instead of bolt and nut; thread length on clevis rod is such that the thread locks the nuts in place, and threads are not in shear plane.

Ordering: Specify pipe size, figure number, name and finish.

Notes: Punched forming holes may be present on certain sizes of this clevis hanger. These holes are solely for the purpose of manufacturing, and do not effect the structural integrity or load carrying capacities of these hangers.

For insulated line options without shields, see Figures 260 ISS and Figure 300. For insulated line options with shields, see Figures 167 and 168. For ductile iron pipe sizes, see Figure 590.

Caution: When an oversize clevis is used, a pipe spacer or multispacer should be placed over clevis bolt to ensure that the lower U-strap will not move in on the bolt.

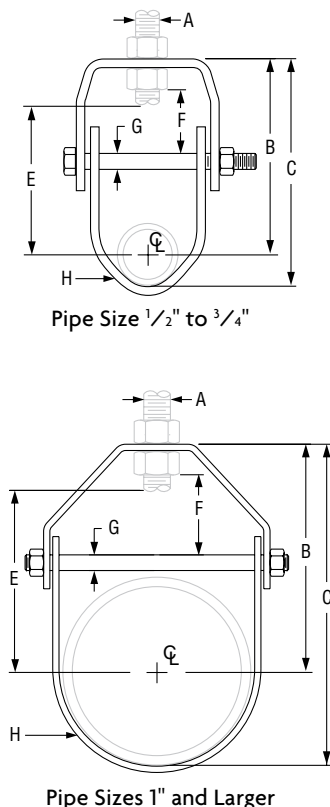
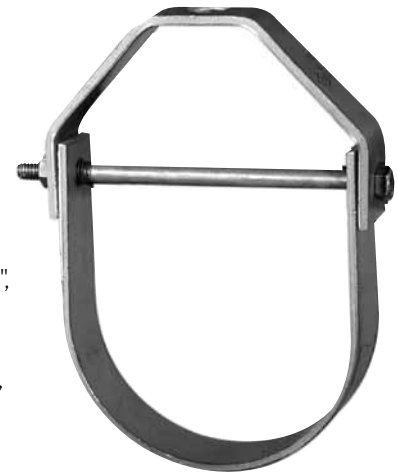

FIG. 260: LOADS (LBS) • WEIGHTS (LBS) • DIMENSIONS (IN)												
Pipe Size	Max Load	Span Ft.	Weight	Rod Size A	B	C	Rod Take Out E	Adjust. F	G	H Width Lower		
1/2	610	7*	0.34	3/8	2 3/16	2 11/16	1 1/2	5/8	1/4	1		
3/4			0.34		2		1 5/16					
1	730	9*	0.35	3/8	2 5/16	3 1/4	1 5/8	7/8	1/4	1		
1 1/4			0.40		2 5/8		1 11/16					
1 1/2			0.45		2 13/16		3 3/16				2 1/8	
2	1,350	11*	0.50	1/2	3 5/16	4 1/2	2 5/8	1 1/8	3/8	1 1/4		
2 1/2			0.65		4 1/16		5 1/2				3 3/16	1 5/16
3			0.85		4 3/4		6 1/2				4 1/16	1 5/8
3 1/2	1,430	13*	1.10	5/8	5 1/16	7 1/16	4 3/16	1 13/16	3/8	1 3/16		
4			1.51		5 9/16		7 13/16				4 1/2	1 11/16
5	1,940	16*	1.70	3/4	6 9/16	8 5/16	5 1/2	1 15/16	1/2	1 7/16		
6			3.10		6 15/16		10 1/4				5 3/4	1 11/16
8	2,000	19*	4.75	3/4	8 3/8	12 11/16	7 3/16	2	5/8	1 3/4		
10			8.60		9 7/8		15 1/4				8 7/16	2 1/8
12	3,800	23*	11.20	7/8	11 9/16	17 15/16	10 1/8	2 3/16	3/4	2		
14			12.50		12 9/16		19 9/16				10 11/16	2 1/16
16	4,600	27	19.85	1	14	22	12	2 3/4	1	2 1/2		
18			22.25		15 15/16		24 15/16				13 15/16	3 3/16
20	4,800	30	40.33	1 1/4	17 7/16	27 9/16	15 1/16	3 7/8	1 1/4	3		
24			49.83		19 13/16		31 13/16				17 9/16	
30	6,000	33	70.18	1 1/4	24 3/16	39 3/16	21 1/16	5 1/8				

"Span" represents the maximum recommended distance between hangers on a continuous and straight run of horizontal standard weight steel pipe filled with water. In all cases, verify that chosen location of hangers does not subject hangers to a load greater than the maximum recommended load shown above. *Indicates that span represents the maximum span for water filled pipe as given in Table 1 of page 211.