

Fig. 256

Pipe Alignment Guide

Size Range: 1" through 24" pipe and insulation thickness of 1" through 4"

Material: Carbon steel

Finish: Plain or Galvanized

Service: For maintaining alignment of piping through its axial expansion and contraction cycles. Normally, two or more pipe alignment guides are used on a single piping run to avoid a pivoting effect within the piping system. It is recommended that the first guide be located a maximum of four pipe diameters from an expansion joint. The second guide should be placed a maximum of 18 pipe diameters from the expansion joint. Additional guides should be employed in accordance with the guide spacing data on next page. Supports are usually required between the intermediate guides to comply with standard support practice.

Maximum Temperature: 750° F

Installation:

- (1) Attach outer housing to structure by bolting or welding.
- (2) Swing upper section of housing to open positions.
- (3) Attach spider clamp to pipe and completely insulate.
- (4) Set pipe and spider clamp into outer housing.
- (5) Replace upper section of housing to closed position and secure.

Note: Spider attachments to pipe must be properly located during installation to insure that a minimum of one-half the spider width remains within the length of the outer housing for all conditions of operation. See table on opposite page for maximum recommended travels. If larger travels are required, special guides can be furnished to special order.

How to size: Size by nominal pipe size and insulation thickness in accordance with the selection table on opposite page.

Ordering: Specify size number, pipe size, insulation thickness, figure number, name and finish.

Caution: The primary function of the Figure 256 is to maintain axial alignment of a system. Other components should be incorporated into the system to carry the primary loading of the system. Guides are designed such that minor loading amounts may be transferred to the guide in any given direction, up to 20% of dead weight load for typical maximum spans of a given pipe diameter.

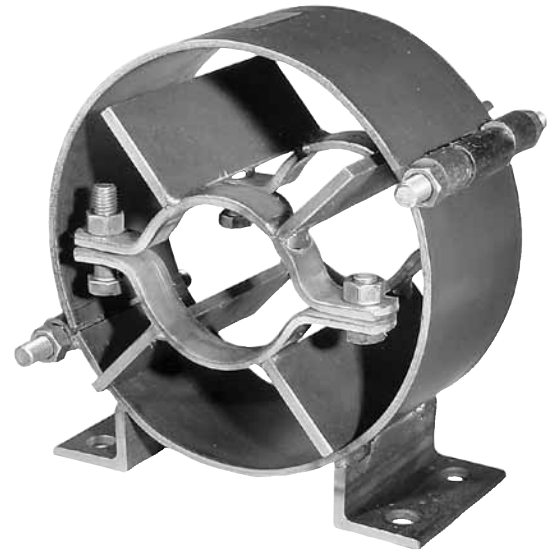

Pipe Size (in)	L (in)	Maximum Movement
1" to 6"	6	6
8" to 16"	8	8
18" to 24"	10	10

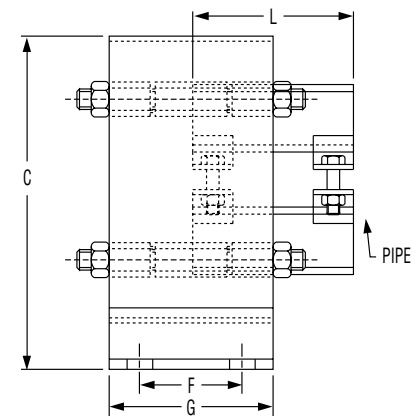
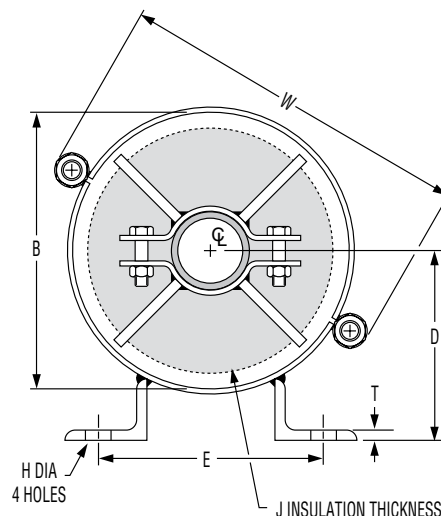

Dimensional Data on Following Page.