

Fig. CT-65

Light Weight Adjustable Clevis

Size Range: 1/2" through 4"

Material: Carbon steel

Finish: Copper plated

Service: Recommended for suspension of non-insulated, **stationary** copper tube.

Approvals: Complies with Federal Specification WW-H-171-E (Type 12).

Installation:

- (1) Adjustment may be made either before or after tubing is in place without temporary support of pipe.
- (2) Hanger rod and nuts may be locked into position after adjustment by use of the upper nut.

Features: Provides for adjustment up to 1 7/8".

Ordering: Specify nominal tube size, figure number, name and finish

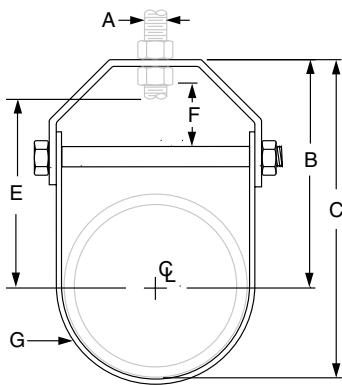

FIG. CT-65: LOADS (LBS) • WEIGHT (LBS) • DIMENSIONS (IN)

Tube Size	Max Load	Weight	Rod Size A	B	C	D	Rod Take Out - E	Adjustment F	G Width Lower
1/2	150	0.09	3/8	1 1/2	1 27/32	1 7/16	1 1/16	5/16	5/8
3/4		0.10		1 11/16	2 3/32	1 9/16	1 1/4	7/16	3/4
1	250	0.17		1 7/8	2 13/32	1 5/8	1 7/16	1/2	
1 1/4		0.18		2 5/32	2 13/16	1 3/4	1 11/16	5/8	
1 1/2		0.21		2 17/32	3 3/8	1 15/16	2 1/16	13/16	
2		0.26		3 11/32	4 17/32	2 5/16	2 7/8	1 3/16	
2 1/2	350	0.48		3 27/32	5 9/32	2 3/4	3 1/4	1 5/16	
3		0.55		4 15/32	6 7/32	3	3 3/8	1 5/8	
4	400	0.60	4 31/32	6 31/32	3 1/4	4 3/8	1 7/8		

Note: Reflects changes in rod diameter from previously published data per recent revisions in MSS-SP-58 & 69