



**QUICK RESPONSE
EXTENDED COVERAGE
LIGHT HAZARD
AUTOMATIC SPRINKLERS
MODEL GL8109
PENDENT**

DESCRIPTION AND OPERATION

The Globe Quick Response Model GL8109 Extended Coverage Pendent Sprinkler for Light Hazard occupancies is a low profile yet durable design which utilizes a 3mm frangible glass ampule as the thermosensitive element. This provides sprinkler operation approximately six times faster than ordinary sprinklers. While this Quick Response Sprinkler provides an aesthetically pleasing appearance, it can be installed wherever standard light hazard extended coverage pendent sprinklers are specified; but offers the additional feature of greatly increased safety to life. Quick Response Sprinklers should be used advisedly and under the direction of approving authorities having jurisdiction, in accordance with their listings and in accordance with NFPA 13.

The heart of Globe's GL Series sprinkler proven actuating assembly is a hermetically sealed frangible glass ampule that contains a precisely measured amount of fluid. When heat is absorbed, the liquid within the bulb expands increasing the internal pressure. At the prescribed temperature the internal pressure within the ampule exceeds the strength of the glass causing the glass to shatter. This results in water discharge which is distributed in an approved pattern.

TECHNICAL DATA

- See reverse side for Approvals and Specifications.
- Temperature Rating - 135°F (57°C), 155°F (68°C), 175°F (79°C) and 200°F (93°C).
- Water Working Pressure Rating - 175 psi (12 Bars).
- Factory tested hydrostatically to 500 psi (34 Bars).
- Maximum low temperature glass bulb rating is -67°F (-55°C).
- Frame - bronze • Deflector - brass • Screw - brass
- Bulb seat - copper • Spring - nickel alloy • Seal - teflon
- Bulb - glass with alcohol based solution, 3mm size.
- Escutcheon Assembly - steel

• SPRINKLER TEMPERATURE RATING/CLASSIFICATION and COLOR CODING

CLASSIFICATION	AVAILABLE SPRINKLER TEMPERATURES		BULB COLOR	N.F.P.A. MAXIMUM CEILING TEMPERATURE	
	135°F/155°F	57°C/68°C		100°F	38°C
ORDINARY	175°F/200°F	79°C/93°C	ORANGE/RED	150°F	66°C
INTERMEDIATE			YELLOW/GREEN		



**QUICK RESPONSE
EXTENDED COVERAGE
PENDENT**



**QUICK RESPONSE
RECESSED
EXTENDED COVERAGE
PENDENT**

QUICK RESPONSE
EXTENDED COVERAGE
LIGHT HAZARD AUTOMATIC SPRINKLERS
MODEL GL8109
PENDENT

SPECIFICATIONS

NOMINAL "K" FACTOR	THREAD SIZE	LENGTH	FINISHES
8.1 (116 metric)	3/4" NPT	3" (7.6 cm)	Factory Bronze Satin Chrome ¹ Bright Chrome White Polyester ² Black Polyester ² Lead Coated ¹

NOTE: METRIC CONVERSIONS ARE APPROXIMATE.

¹FINISHES AVAILABLE ON SPECIAL ORDER.

²AVAILABLE AS cULus LISTED CORROSION RESISTANT WHEN SPECIFIED ON ORDER.

APPROVALS

STYLE	SIN MODEL	K FACTOR	135°F 57°C	155°F 68°C	175°F 79°C	200°F 93°C	cULus
PENDENT	GL8109	8.1	X	X	X	X	X

U.L. LISTING DESIGN - USE REQUIREMENTS FOR LIGHT HAZARDS ONLY

SIN MODEL	STYLE	TEMP.	AREA OF COVERAGE	MIN. PRESSURE P.S.I.	FLOW IN G.P.M.
GL8109	Standard & Recessed	135°F/57°C	16' x 16'	10.3	26
		155°F/68°C 175°F/79°C 200°F/93°C	18' x 18'	16.6	33
		135°F/57°C	20' x 20'	24.4	40

NOTE: DUE TO THE HIGH SPRAY PATTERN CREATED BY THIS SPRINKLER, THERE MUST BE A MINIMUM SPACING OF 8'-0" BETWEEN SPRINKLERS TO ELIMINATE THE RISK OF COLD SOLDERING.

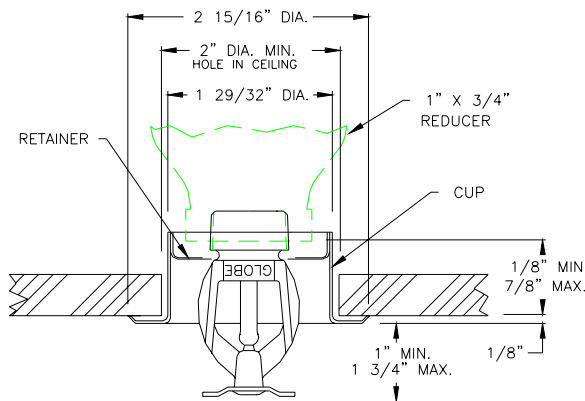

CROSS SECTION



ORDERING INFORMATION

SPECIFY

- Quantity • Model Number • Style
- Orifice • Temperature • Finishes desired
- Quantity - Wrenches - P/N 312366
- Quantity - Recessed Wrenches - P/N 325401, Rev. D
- Quantity - Protective Caps - P/N 327109-CAP (Friction Fit Recessed)

GLOBE® PRODUCT WARRANTY

Globe agrees to repair or replace any of its own manufactured products found to be defective in material or workmanship for a period of one year from date of shipment.

For specific details of our warranty, please refer to Price List Terms and Conditions of Sale (Our Price List).

4077 AIRPARK DRIVE, STANDISH, MICHIGAN 48658

989-846-4583

FAX 989-846-9231

1-800-248-0278

www.globesprinkler.com