

# CLEVIS HANGERS

## Fig. 300

## Adjustable Clevis for Insulated Lines

**Size Range:** 3/4" through 12"

**Material:** Carbon steel

**Finish:** Plain, Galvanized or Epoxy coated

**Service:** Recommended for suspension of insulated **stationary** pipe lines.

**Maximum Temperature:** Plain 650° F, Galvanized and Epoxy 450° F

**Approvals:** Complies with Federal Specification A-A-1192A (Type 1) WW-H-171-E (Type 1), ANSI/MSS SP-69 and MSS SP-58 (Type 1).

**Installation:** Hanger load nut above clevis must be tightened securely to assure proper hanger performance.

**Adjustment:** Vertical adjustment is provided, varying with the size of the clevis. Tighten upper nut after adjustment.

**Features:**

- Designed for 2" of insulation on 3/4" through 1 1/2" pipe and 4" of insulation on 2" and larger pipe.
  - When properly installed, clevis bolt is outside the insulation.
- Ordering: Specify pipe size, figure number, name and finish.

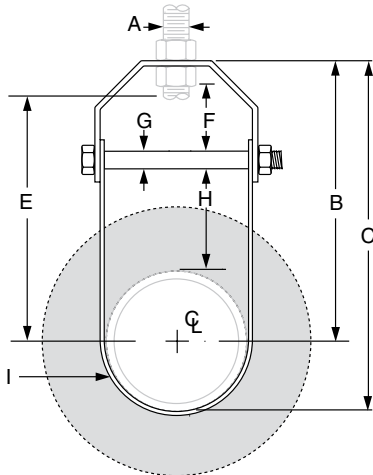

**FIG. 300: LOADS (LBS) • WEIGHT (LBS) • DIMENSIONS (IN)**

Pipe Size	Max Load	Weight	Rod Size A	B	C	E	Adjustment F	G	H	I Width Lower
3/4	730	0.51	3/8	3 5/8	4 1/4	2 7/8	1/2	1/4	2	1
1		0.58		4	4 11/16	3 1/4	5/8			
1 1/4		0.64		4 7/16	5 1/4	3 5/8	7/8			
1 1/2		0.72		4 3/4	5 3/4	4 1/16	1 1/16			
2		0.85		7 7/16	8 11/16	6 1/2	1 5/8			
2 1/2	1,350	1.90	1/2	8 7/16	9 15/16	7 1/2	2	3/8	4	1 1/4
3		2.00		8 5/8	10 5/16	7 9/16	1 3/4			
4	1,430	2.50	5/8	9 3/8	11 5/8	8 3/16	1 15/16	1/2	4	1 1/2
5		3.00		9 7/8	12 5/8	8 3/4	1 3/4			
6		3.40		10 5/8	14	9 3/8	1 7/8			
8	2,000	6.70	3/4	12 3/8	16 3/4	11	2	5/8	4	1 3/4
10	3,600	11.0		13 3/4	19 9/16	12 1/4	2 1/8			
12	3,800	13.8		15 1/8	21 9/16	13 3/8	2 7/16			