

ACCELERATOR AND ANTI-FLOODING DEVICE MODEL C

DESCRIPTION AND OPERATION

Globe's Model C Accelerator is a precision made device used to reduce the time lag normally associated with the opening of a Dry Pipe Valve after one or more system sprinklers have operated. In essence, the Model C Accelerator "accelerates" the opening of the Dry Pipe Valve resulting in faster water discharge from the opened sprinkler(s).

The Model C Accelerator basically monitors the air pressure in a Dry Pipe System. If a rapid loss of system air pressure occurs, as would with the opening of one or more sprinklers, the accelerator senses this loss and immediately sends pressurized air to the intermediate chamber of the Dry Pipe Valve upsetting the pressure differential and causing it to operate instantly.

Globe incorporates the use of its Model C Anti-Flooding Device to help ensure the proper operation of the Model C Accelerator by preventing most water-borne foreign objects from entering the Accelerator. Such objects could cause clogging of the Accelerator and hinder its proper operation. Because of its importance, the Model C Anti-Flooding Device is always included with orders for the Model C Accelerator and should always be properly installed. Accelerators are precision made devices, however, and must be kept clean of foreign matter. A thorough cleaning after use is recommended.

After the Accelerator has operated, the pressurized air in the Accelerator Body and its associated piping is discharged to the Model C Anti-Flooding Device's lower inlet stopping any flow through the piping leading to the Accelerator. This occurs very quickly and always before water reaches the Anti-Flooding Device.

APPROVALS

- cULus Listed
- F.M. Approved
- N.Y.C. - D.O.B. MEA 353-91-M

TECHNICAL DATA

- Water Working Pressure Rating - 175 psi (1207 kPa).



ACCELERATOR

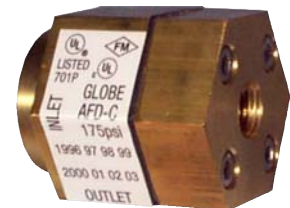

**ANTI-FLOODING
DEVICE**

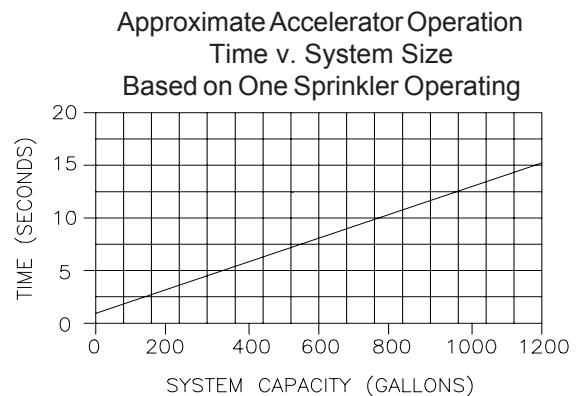

ACCELERATOR AND ANTI-FLOODING DEVICE MODEL C

CROSS SECTIONS

TO PRESSURE
GAUGE

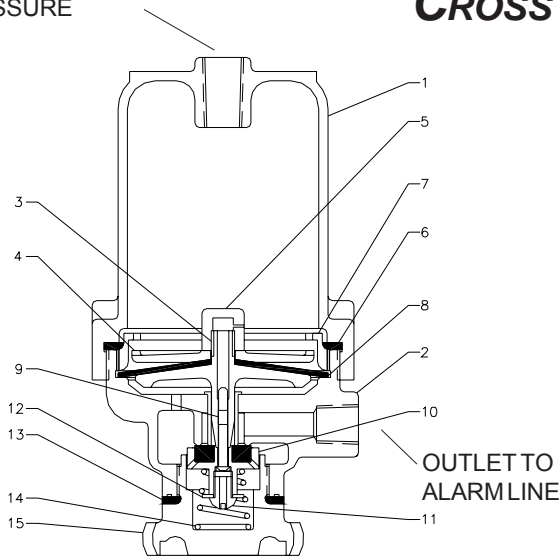

FRONT VIEW

ITEM	DESCRIPTION	MATERIAL	PART NO.
1	Upper Chamber	Bronze	300401
2	Lower Chamber and Valve Seat Assembly	Bronze	300402
3	Pressure Plate	Brass	300405
4	Diaphragm Plate	Brass	300406
5	Nut	Bronze	300407
6	Gasket	EPD.M.	300408
7	Clamping Ring	Brass	300409
*8	Diaphragm	Neoprene	300410
9	Restricted Orifice Pin	Monel	300411
10	Valve Disc and Disc Retainer Assembly	Neoprene/Brass	300412
11	Retaining Screw	Bronze	300415
12	Spring Retainer Disc	Brass	300416
13	Gasket	EPD.M.	300417
14	Spring	Bronze	300418
15	Plug	Brass	300419

*323489 Accelerator Clamping Ring Wrench (Item #7) for use when replacing the Diaphragm Item #8.

ACCELERATOR

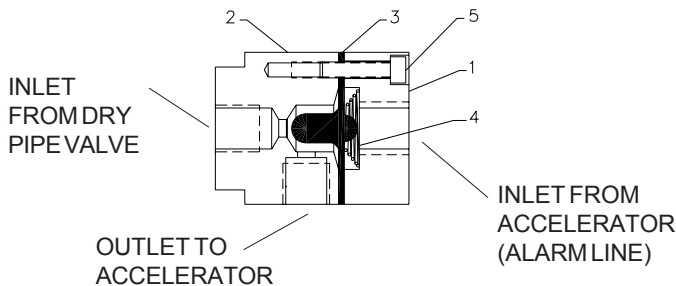

ITEM	DESCRIPTION	MATERIAL	PART NO.
1	Top	Brass	323334
2	Body	Brass	323333
3	Diaphragm	E.P.D.M.	323335
4	Spring	Stainless Steel	323336
5	Screw	Steel	323337

ANTI-FLOODING DEVICE

Refer to Globe's Dry Pipe Valve Installation and Maintenance Guide (Bulletin D.P.V.I.M.) for trim set-up.

ORDERING INFORMATION

SPECIFY

- Quantity • Model Number
- Untrimmed or Factory Trimmed and Leak Tested Hydrostatically

GLOBE® PRODUCT WARRANTY

Globe agrees to repair or replace any of its own manufactured products found to be defective in material or workmanship for a period of one year from date of shipment.

For specific details of our warranty please refer to Price List Terms and Conditions of Sale (Our Price List).



4077 AIRPARK DRIVE, STANDISH, MICHIGAN 48658

989-846-4583

1-800-248-0278

FAX 989-846-9231

www.globesprinkler.com