

## Fig. 243

### Pipe Strap

**Size Range:** 1/2" through 6" pipe  
**Material:** Carbon steel  
**Finish:** Plain  
**Service:** Restraint of pipe in specified direction while permitting movement in non-restrained direction.  
**Maximum Temperature:** 650° F  
**Ordering:** Specify figure number, name, and pipe size. Larger sizes available upon request.

**FIG. 243:  
LOADS (LBS) • WEIGHT (LBS) • DIMENSIONS (IN)**

Pipe Size	L	T	W	Rated Load P <sub>n</sub>	Weight
1/2	3	1/4	2	600	0.71
3/4	3 1/2				0.84
1	4				0.98
1 1/4	4 1/2	3/8	3	1,500	2.64
1 1/2	5				2.94
2	5 1/2				3.39
2 1/2	6	1/2	4	2,500	5.20
3	6 1/2				7.93
4	7 1/2				9.63
6	9 3/4				19.97

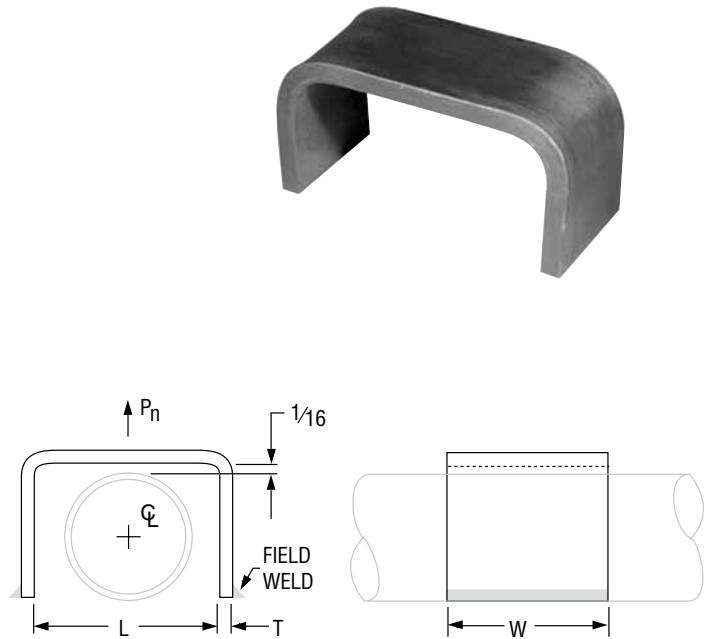

## Fig. 244

### Pipe Strap

**Size Range:** 1/2" through 6" pipe  
**Material:** Carbon steel  
**Finish:** Plain  
**Service:** Restraint of pipe in specified direction while permitting movement in non-restrained direction.  
**Maximum Temperature:** 650° F  
**Ordering:** Specify figure number, name, and pipe size. Larger sizes available upon request.

**FIG. 244:  
LOADS (LBS) • WEIGHT (LBS) • DIMENSIONS (IN)**

Pipe Size	Rated Load		L	T	W	Weight
	P <sub>s</sub>	P <sub>n</sub>				
1/2	250	1,500	1	1/4	2	0.39
3/4			1 3/16			0.47
1			1 7/16			0.56
1 1/4	500	2,000	1 3/4	3/8	3	1.62
1 1/2			2			1.81
2			2 1/2			2.20
2 1/2	650	2,300	3	1/2	4	3.56
3			3 7/8			5.74
4			4 3/4			7.16
6	700		6 3/4		6	15.32

