

**Metraflex**  
*for pipes in motion*

**BIM**  
**3D**  
online

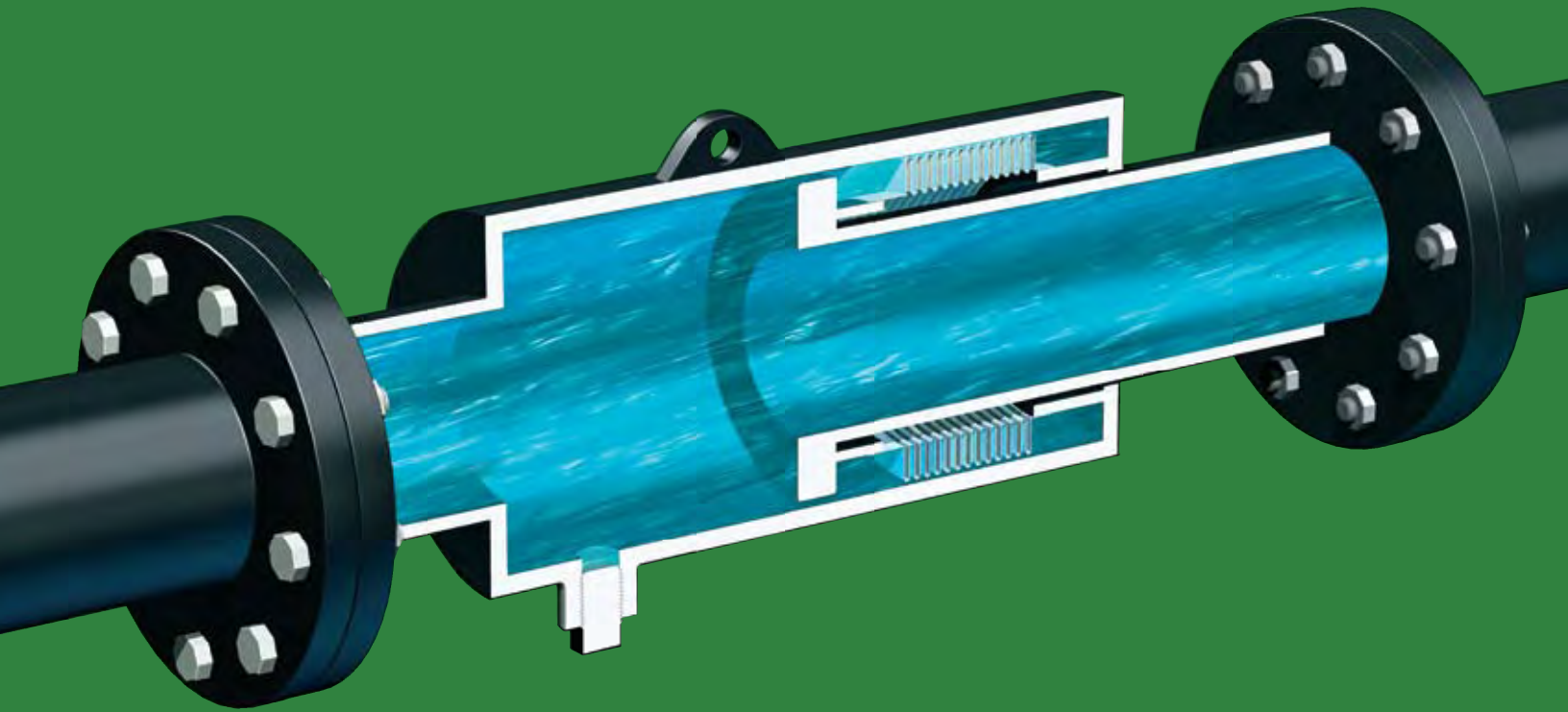

# MetraGator

Externally pressurized  
expansion joint



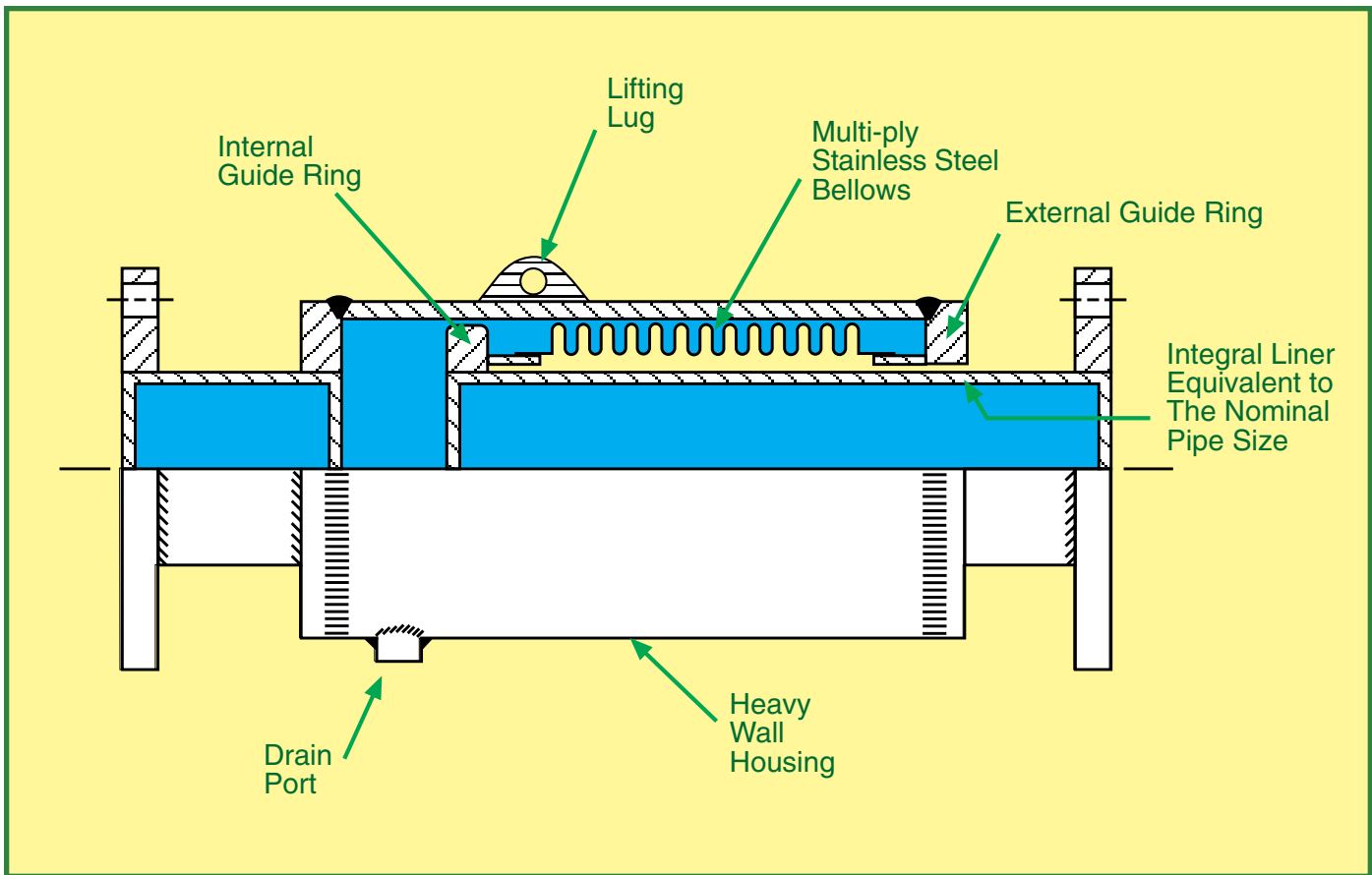

**This unique expansion joint design, incorporating an externally pressurized bellows, imparts upon the MetraGator a number of advantages over the traditional internally pressurized joint.**

- Large axial movements. External pressurization eliminates bellows squirm allowing longer movements of 4, 6 or 8 inch for single units, and 12 or 16 inch movements for dual units.
- Maintenance free. All welded construction, no packing!
- Integral liner. The bellows is not exposed directly to any abrasive impact of the flowing media. No erosion.
- Self cleaning bellows. With the media on the outside of the bellows there is no accumulation of sediment in the root of the convolutions.
- Cover / Housing. The heavy wall housing adds extra protection to the joint minimizing external damage.

## Specification:

1. General:
  - a. Expansion joints to be of the packless, externally pressurized type where system line pressure is external to the bellows.
  - b. All joints to be provided with drain connection and lifting lug. Double end joints shall have anchor base to act as intermediate anchor.
  - c. All materials of construction, pressure ratings, and end fittings shall be appropriate for the application. Guiding and anchoring per EJMA recommendations and guidelines
2. Products
  - a. Manufacturer: Expansion joints shall be “**MetraGator**” as manufactured by The Metraflex Company®, Chicago, IL.
  - b. Performance: Expansion joints shall be pressure rated for 150psi @ 700 F or 300psi @ 700°F. as required.
  - c. Movement capabilities to be 4”, 6”, or 8” axial movement, as required.
  - d. Construction: All welded construction with stainless steel bellows, steel shroud, integral guide rings, and internal liner.
  - e. Bellows: shall be low corrugation style manufactured from T304 stainless steel. The number of corrugations and overall length of the expansion joints shall be determined by the thermal expansion requirements, system design engineer, and manufacturer’s recommendations based on EJMA (Expansion Joint Manufacturers Association) standards.
3. Execution
  - a. Guiding: Pipe guides adjacent to the expansion joint shall be in accordance to EJMA guidelines based on design pressure and line size.
  - b. When installed in vertical pipe runs expansion joint shall be installed with the traveling end on top.
  - c. Drain: Expansion joint shall be installed so that the drain connection is on the low end of the joint.
  - d. Installation shall be in accordance to manufacturers printed instructions.

## Installation:

The **MetraGator** can be installed at any location in the pipe run and in any orientation, horizontal, vertical and anything in-between.

Although there is no flow direction for the joint, if the joint is to be installed in a vertical line, it should be installed with the traveling nipple up. This will allow the joint to drain, preventing liquid and sediment from accumulating between the housing and bellows.

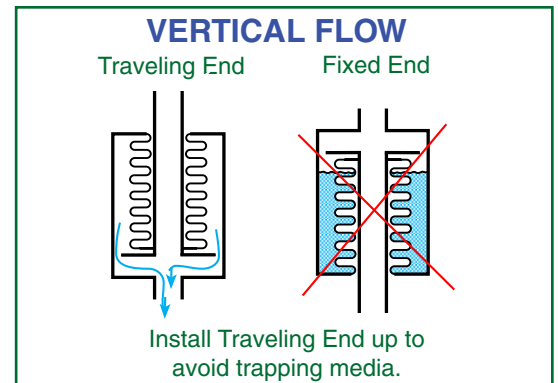

## Anchoring and Guiding:

Anchoring and guiding requirements are similar to most bellows type expansion joints. Any pipeline with expansion joints must have anchors at the end of the pipe run sufficiently strong to withstand the pressure thrust imposed by the effective area of the joint plus the joint’s spring rate. Guides are also required to prevent the pipe from bowing. (See Metraflex’s Expansion joint design guide for full details.)

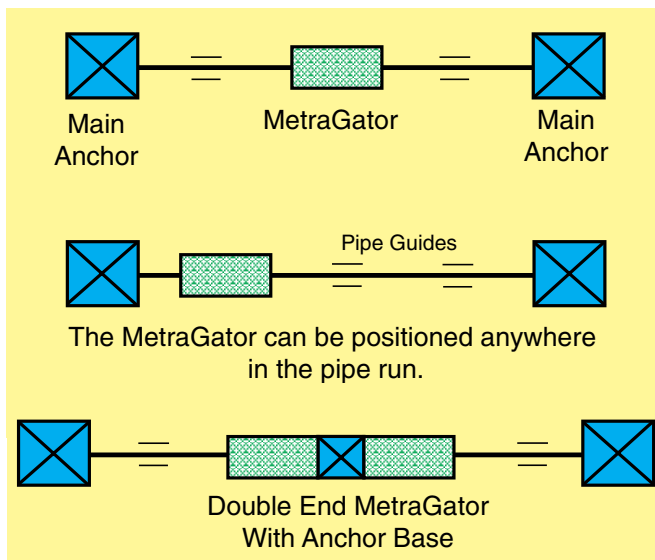

Anchor loads can be calculated from the information given in the tables using the following formula:

$$\text{Main Anchor Load} = \text{Effective Area of Joint} \times \text{Maximum System Pressure} + (\text{Spring Rate} \times \text{Actual Movement})$$

Sample calculation for a 6” diameter 150# METRAGATOR, maximum pressure of 135 psi, and 3.25 inches of movement.

$$\begin{aligned} \text{Main Anchor Load} &= 58.9 \text{ in}^2 \times 135 \text{ psi} + (269 \text{ lbs/in} \times 3.25 \text{ ins}) \\ &= 8,825.75 \text{ lbs} \end{aligned}$$

Anchor Bases are typically provided on double end joints which are installed in the middle of the pipe run. This anchor base would be classified as an intermediate anchor and as such is not designed to withstand the loads seen by main anchors. Contact factory for more information.

**OPTIONS:** METRAGATORS can be custom made in almost any weldable material with almost any end

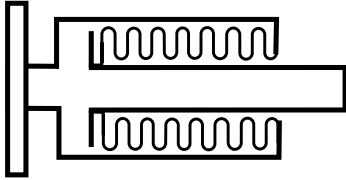

**Flanged by Weld End**

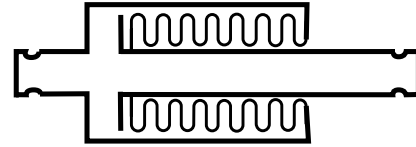

**Grooved Ends**

Use only Non flexing couplings  
and consult coupling manufacturer

**STANDARD CONSTRUCTION:** Stainless Steel Bellows, Carbon Steel Housing, Plate Steel Flange

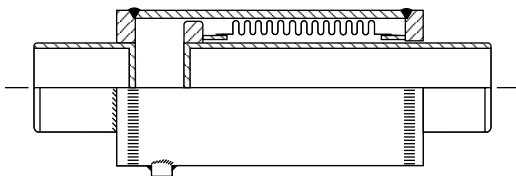

**Weld End**

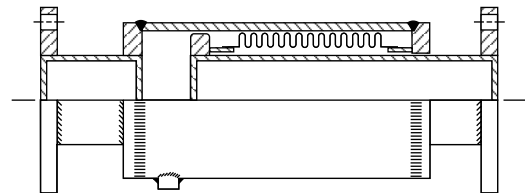

**Flanged End**

150 PSI WORKING PRESSURE AT 700°F (225 psi max. test press.)								
SIZE (mm)	AXIAL COMPRES- SION	WELD ENDS		FLANGED ENDS		HOUSING O.D.	EFFECTIVE AREA (in sq.)	SPRING RATE (lbs./in.)
		OAL	LBS	OAL	LBS			
2" (50)	4"	24-1/2"	26	24-7/8"	34	5-1/2"	13	183
	6	31	33	31-5/8"	41			115
	8	37-3/4	42	38-3/8"	50			92
2-1/2" (65)	4"	24-1/2"	29	25-1/8"	40	5-1/2"	13	183
	6	31-1/4	37	31-7/8"	48			115
	8	38	47	38-5/8"	58			92
3 (80)	4"	23-1/4	38	23-7/8"	51	6-5/8"	21	343
	6	29-1/2	47	30-1/8"	60			235
	8	37-3/4	62	38-3/8"	75			172
4 (100)	4"	24-1/4	59	23-7/8"	75	8-5/8"	36	200
	6	30-3/4	73	31-3/8"	89			143
	8	37-1/4	94	37-7/8"	110			103
5 (125)	4"	24-1/4	91	25	112	10-3/4"	47	235
	6	30-3/4	112	31-1/2"	133			166
	8	37-1/2	144	38-1/4"	165			120
6 (150)	4"	24-3/4	115	25-1/2"	138	12-7/8"	59	269
	6	31-1/2	139	32-1/4"	162			189
	8	37-3/4	177	38-1/2"	200			138
8 (200)	4"	27-1/4	153	28-1/4"	198	14"	89	332
	6	33-3/4	185	34-3/4"	230			235
	8	41	238	42	283			166
10 (250)	4"	26	186	27	240	16"	125	400
	6	33	227	34	281			280
	8	39-1/4	288	40-1/4"	342			200
12 (300)	4"	26	226	27	308	18"	167	463
	6	32-1/4	273	33-1/4"	355			326
	8	38-3/4	346	39-3/4"	428			235

Larger Size - Consult Factory

and configuration. - Consult factory for your specific needs.

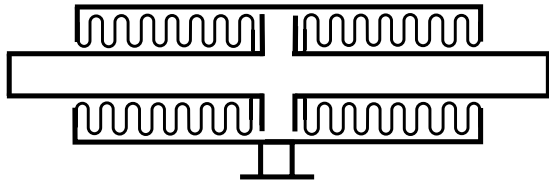

**Dual Weld End**  
with Anchor Base

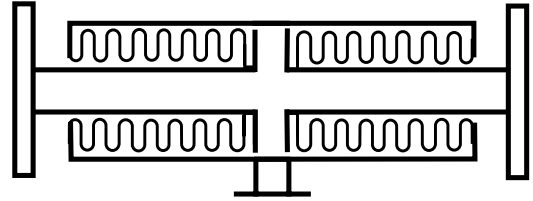

**Dual Flanged End**  
with Anchor Base

or Schedule 40 Weld Ends.

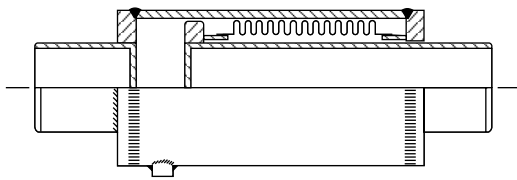

**Weld End**

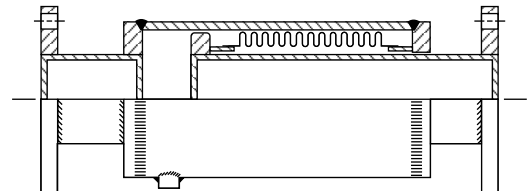

**Flanged End**

300 PSI WORKING PRESSURE AT 700°F (450 psi max. test press.)								
SIZE (mm)	AXIAL COMPRES- SION	WELD ENDS		FLANGED ENDS		HOUSING O.D.	EFFECTIVE AREA (in sq.)	SPRING RATE (lbs./in.)
		OAL	LBS	OAL	LBS			
2" (50)	4"	23-1/4"	35	25-3/4"	49	5-9/16"	12	388
	6	32	48	34-3/4	63			260
	8	39-1/4	58	41-3/4	72			194
2-1/2 (65)	4"	23-1/4"	36	25-3/4"	56	5-9/16"	12	388
	6	32	52	34-3/4	73			260
	8	39-1/4	63	41-3/4	84			194
3 (80)	4"	22-1/4"	47	24-3/4"	75	6-5/8"	16	504
	6	28-1/2	59	31-1/4	87			380
	8	37-1/4	78	39-3/4	106			252
4 (100)	4"	22-3/4"	74	25-3/4"	121	8-5/8"	30	850
	6	29-1/2	94	32-1/2	141			566
	8	38-1/2	124	41-1/4	170			424
5 (125)	4"	21-1/2"	97	24-1/2"	158	10-3/4"	42	1002
	6	27-1/2	120	30-3/4	181			668
	8	33-3/4	143	36-3/4	203			501
6 (150)	4"	21-1/2"	106	25-1/4"	190	10-3/4"	53	1140
	6	27-1/2	130	31-1/4	214			760
	8	33-3/4	155	37-1/2	239			570
8 (200)	4"	22-1/2"	168	26-3/4"	295	12-3/4"	83	2424
	6	29	209	33-1/2	336			1616
	8	35-3/4	250	40	377			1212
10 (250)	4"	23-3/4"	216	28-1/2"	396	16"	135	3266
	6	30-3/4	272	35-3/4	452			2177
	8	40	354	44-3/4	534			1633
12 (300)	4"	25"	285	30-1/2"	540	18"	182	3491
	6	32-1/2	355	38-1/4	610			2327
	8	42-1/4	457	47-3/4	712			1745

Larger Size - Consult Factory