

Fig. 986 - Mechanical Fast Clamp

Size Range — Standard 1/2" anchor available, for other sizes consult factory

Material — Carbon steel

Function — Used for attachment of seismic bracing to pipe hanger or trapeze

Features —

- Allows up to 12" of adjustability in brace length, when used with Fig. 985
- Break-off bolt heads visually verify required installation torque
- Swivel allows adjustment to various surface angles

Finish — Electro-galvanized

Order By — Figure number, rod size & finish

PATENT PENDING

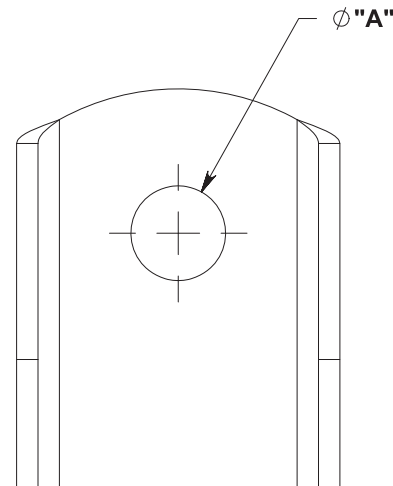
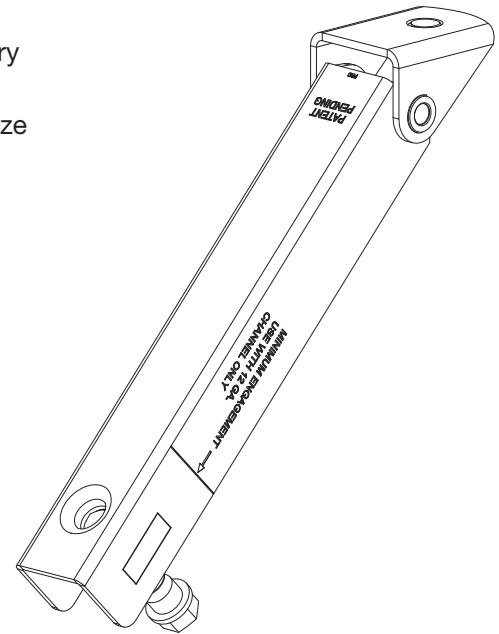

Fig. 986

Dimensions • Weights

Rod Size	A	Max. Rec. Load Lbs.*	Approx Wt./100
1/2	9/16"	2015	204

* When used with 1-5/8" x 1-5/8" 12 gauge channel

