

**Class 125 • Bolted Bonnet • Non-Rising Stem • All Iron • Flanged Ends**

**Figure 473**

Flanged - All Iron

**Size Range:**

2 through 8 inches

**Working Pressures Non-Shock**

200 psi Cold Working Pressure

**Features**

- Tapered Solid Wedge Disc
- Body Guide Ribs
- Integral Seats
- Stem with ACME Double Threads
- Non-Asbestos Packing and Gaskets
- MSS SP-70 Type 1 and MSS SP-25
- ASME B16.10, ASME B16.1
- Valves can be equipped with by-passes when specified

For more detailed features, refer to Page 9.

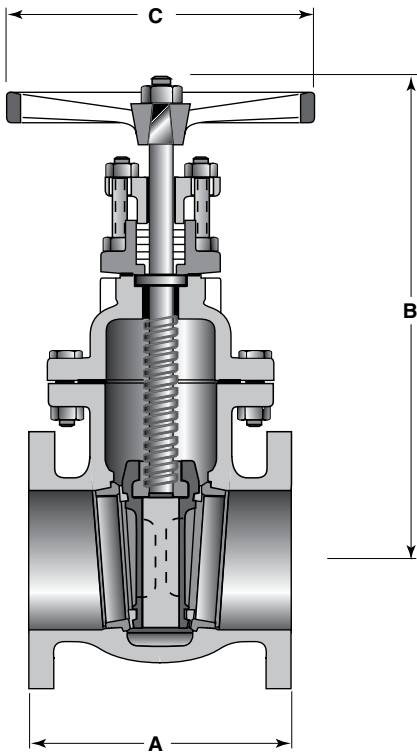

**Principal Parts & Materials**

Fig. No.	Size	Stem	Seating	End Conn.
473	2" - 8"	Steel Nickel plated	Iron	Flanged

**Dimensions and Weights**

Inches (millimeters) - pounds (kilograms)

Valves	2	2 ½	3	4	5	6	8
	(50)	(65)	(80)	(100)	(125)	(150)	(200)
A	7.00 (178)	7.50 (191)	8.00 (203)	9.00 (229)	10.00 (254)	10.50 (267)	11.50 (292)
B	11.31 (287)	12.40 (315)	13.25 (337)	16.31 (414)	18.00 (457)	20.69 (526)	24.12 (613)
C	8.00 (203)	8.00 (203)	8.00 (203)	10.00 (254)	10.00 (254)	12.00 (305)	14.00 (356)
Wt.	30 (14)	44 (20)	56 (25)	91 (41)	126 (57)	152 (69)	260 (118)