

200 CWP • Threaded Cap • Brass/Bronze Disc • Solder Ends

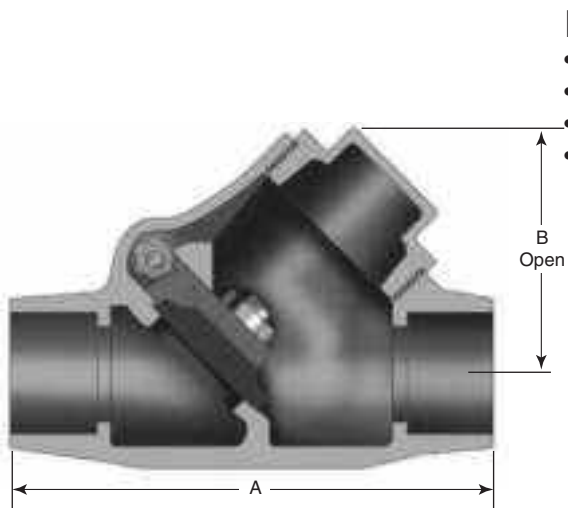

Features

- Y-Pattern Body
- Solder Joint Ends
- Screwed Cap
- MSS Specification SP-80, Type 3

For more detailed features, refer to page 47.

Figure 1340

Size Range:

½" through 3"

Working Pressures Non-Shock:

200 psi Cold Working Pressure

Principal Parts & Materials

Part	Size	Material	ASTM
Body	All	Bronze	B62 alloy C83600
Cap	All	Bronze	B61 alloy C92200
Disc	½"–¾"	Brass	B16 alloy H02
Disc	1"–3"	Bronze	B62 alloy C83600
Hinge	All	Bronze	B584 alloy C87600
Hinge Pin	All	Stainless Steel	A276 type 304

Dimensions and Weights

Inches (millimeters) - pounds (kilograms)

	½ (15)	¾ (20)	1 (25)	1 ¼ (32)	1 ½ (40)	2 (50)	2 ½ (65)	3 (80)
A	2.69 (68)	3.63 (92)	4.25 (108)	4.81 (122)	5.56 (141)	6.87 (174)	7.78 (198)	9.19 (233)
B	1.63 (41)	2.00 (51)	2.50 (62)	3.00 (76)	3.50 (89)	4.00 (102)	4.75 (121)	5.63 (143)
WTS.	0.60 (0.27)	1.00 (0.45)	1.50 (0.68)	2.20 (1.00)	3.30 (1.50)	5.40 (2.45)	9.20 (4.17)	14.30 (6.49)