

TRANSITION PUNCH TEES

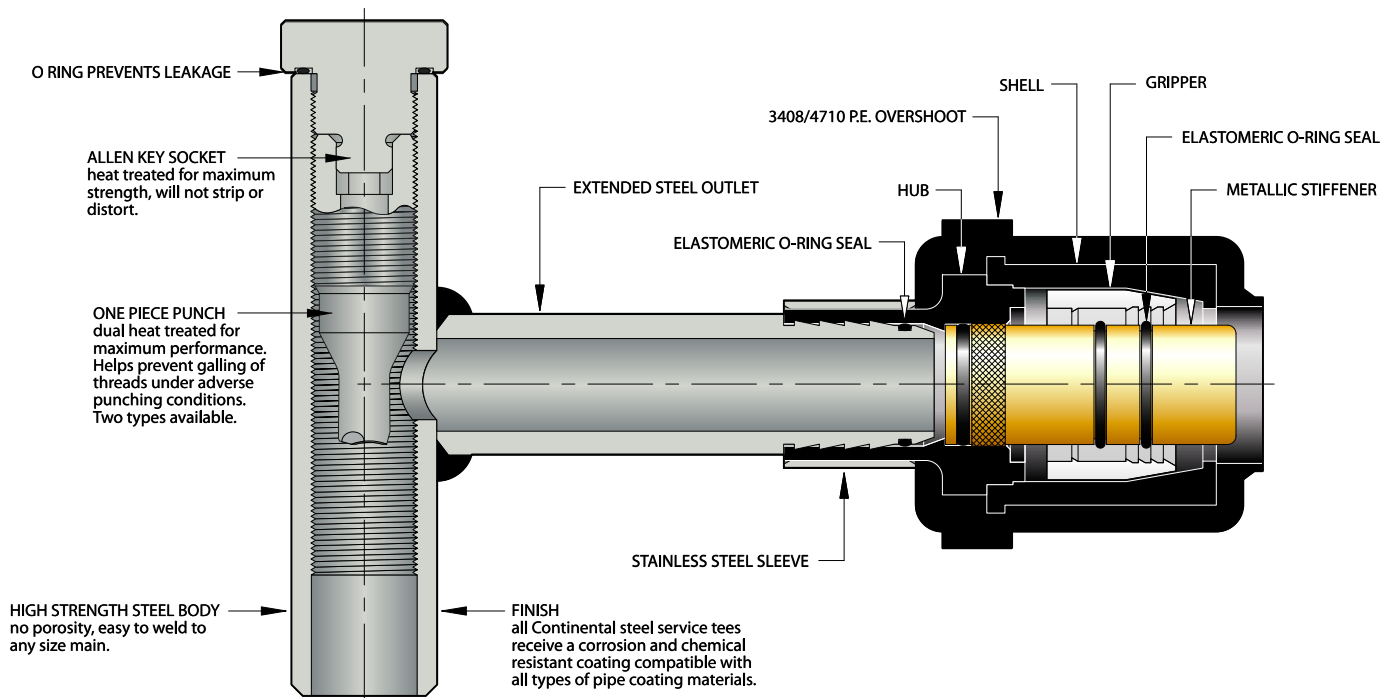

CON-STAB ID SEAL® TRANSITION SERVICE PUNCH TEES WITH SEAL PLUG CAP

The Most Foolproof, Versatile, Economical Punch Tee Available!



- CAP SCREWS DOWN INSIDE TEE BODY
- O-RING IN CAP PREVENTS LEAKAGE, NO NEED FOR TEFLON TAPE OR THREAD SEALANT
- CAP CAN BE TIGHTENED BY HAND TO SEAL AT 800 PSI
- WELDS ARE TESTED TO 800 PSI
- PUNCH PROVIDES POSITIVE VALVE ACTION AT MAIN
- FAST - NO BULKY DRILLING EQUIPMENT NEEDED
- SAFE - NO BLOWING OF GAS
- TWO TYPES OF PUNCHES AVAILABLE (SEE PG 31)
- AVAILABLE IN WELD, THREADED OR SADDLE INLETS