

Material

	764-WE, 765M-WE, 766M-WE, 767-WE
Body	Carbon Steel, ASTM A216 Grade WCB
Cover	Carbon Steel, ASTM A216 Grade WCB
Gasket	Spiral Wound SS, Graphite Filled

ALSO AVAILABLE:

Body/Cap: Carbon-Moly ASTM A217 Gr. W1,
 Chrome-Moly ASTM A217 Gr. WC6,
 Chrome-Moly ASTM A217 Gr. WC9

Pressure Drop

See Pressure Drop Charts in Technical Data Section of the Mueller Steam Specialty Engineering binder.

Dimensions and Weights

SIZE	DIMENSIONS								WEIGHT	
	A		B		C		D Screen Removal		lbs.	kgs.
in. mm	in.	mm	in.	mm	in.	mm	in.	mm	in.	mm
764-WE										
1/2 15	6 5/8	168	3 1/2	89	3/8	10	5	130	6	2.7
3/4 20	8 5/16	211	3 3/4	95	1/2	15	5	130	12.3	5.5
1 25	8 5/16	211	3 3/4	95	1/2	15	5	130	12.3	5.5
1 1/4 32	10 5/8	257	5 1/2	140	1/2	15	8	203	19	8.6
1 1/2 40	10 3/4	260	5 1/2	140	1/2	15	8	203	27	12
2 50	11	279	7	178	1/2	15	10	254	40	18
2 1/2 65	12	305	8 1/4	210	1	25	12 1/2	318	60	27
3 80	13 1/2	343	9 1/4	235	1 1/4	32	14 1/2	368	78	35
4 100	17 15/16	456	12 1/2	318	1 1/2	40	19 1/2	495	160	72.7
5 125	22 1/4	565	15	381	2	50	23	584	254	115
6 150	25 5/8	651	20	508	2	50	31	787	364	165
8 200	31 3/4	806	24	610	2	50	38 1/2	978	670	304
10 250	37 11/16	957	28 1/2	724	2	50	45 1/2	1156	1090	495
12 300	45 1/2	1156	34 1/2	876	2	50	52	1321	1558	708

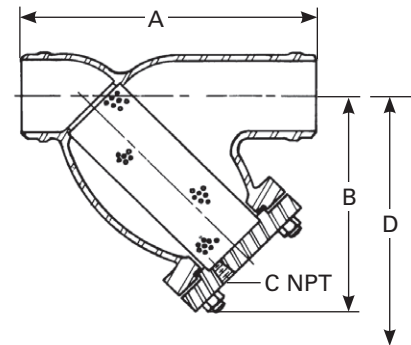

Model 764WE

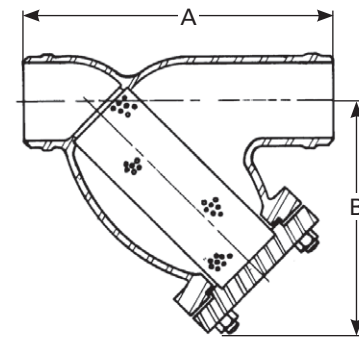

Models 765M-WE, 766M-WE, 767-WE

SIZE	DIMENSIONS				WEIGHT	
	A		B		lbs.	kgs.
in. mm	in.	mm	in.	mm	lbs.	kgs.
765M-WE						
1/2 15	8 1/8	206	4 1/4	108	20	9
3/4 20	9 1/16	230	4 3/4	121	30	13.6
1 25	10 11/16	271	5 3/4	146	52	23
1 1/4 32	12	305	6 3/4	171	64.5	29
1 1/2 40	12	305	6 3/4	171	64.5	29
2 50	13 15/16	354	7 1/2	191	93	42
2 1/2 65	17 1/2	445	10 3/4	273	185	84
3 80	17 1/2	445	10 3/4	273	185	84
4 100	23 1/4	591	15	381	250	113
5 125	—	—	—	—	—	—
6 150	27 3/4	705	18 5/8	479	560	254
8 200	33 3/4	846	23 3/8	606	1000	454
10 250	CF	CF	CF	CF	CF	CF
12 300	CF	CF	CF	CF	CF	CF

SIZE	DIMENSIONS				WEIGHT	
	A		B		lbs.	kgs.
in. mm	in.	mm	in.	mm	lbs.	kgs.
766M-WE						
1/2 15	8 1/8	206	4 1/4	108	20	9
3/4 20	9 1/16	230	4 3/4	121	30	13.6
1 25	10 11/16	271	5 3/4	146	52	23
1 1/4 32	12	305	6 3/4	171	64.5	29
1 1/2 40	12	305	6 3/4	171	64.5	29
2 50	13 15/16	354	7 1/2	191	93	42
2 1/2 65	17 1/2	445	10 3/4	273	185	84
3 80	17 1/2	445	10 3/4	273	185	84
4 100	23 1/4	591	15	381	334	151
6 150	30 5/8	778	18 5/8	479	770	350
8 200	CF	CF	CF	CF	CF	CF
10 250	CF	CF	CF	CF	CF	CF
12 300	CF	CF	CF	CF	CF	CF

SIZE	DIMENSIONS				WEIGHT	
	A		B		lbs.	kgs.
in. mm	in.	mm	in.	mm	lbs.	kgs.
767-WE						
1/2 15	12 5/8	321	7 11/16	195	30	13.6
3/4 20	12 5/8	321	7 11/16	195	40	18
1 25	12 5/8	321	7 11/16	195	65	29.5
1 1/4 32	16 5/8	429	10 1/2	267	140	63.3
1 1/2 40	16 5/8	429	10 1/2	267	140	63.6
2 50	18 15/16	481	12 1/2	318	240	109
2 1/2 65	25 3/4	654	18 13/16	478	500	227
3 80	26 3/4	679	18 13/16	478	560	254
4 100	33 5/8	854	20 1/4	514	850	386
6 150	33 3/4	857	20	508	1900	862
8 200	CF	CF	CF	CF	CF	CF
10 250	CF	CF	CF	CF	CF	CF
12 300	CF	CF	CF	CF	CF	CF

Mueller Steam Specialty product specifications in U.S. customary units and metric are approximate and are provided for reference only. For precise measurements, please contact Mueller Steam Specialty Technical Service. Mueller Steam Specialty reserves the right to change or modify product design, construction, specifications, or materials without prior notice and without incurring any obligation to make such changes and modifications on Mueller Steam Specialty products previously or subsequently sold.



A Watts Water Technologies Company

ES-MS-764WE_765MWE_766MWE_767WE 1020

USA: St. Pauls, NC • Tel. 1-800-334-6259 • Fax 1-800-421-6772 • www.muellersteam.com



© 2010 Mueller Steam Specialty