

Class 250 • Bolted Cap • Bronze Trim • Flanged Ends

Features

- For steam, water, oil, gas and similar high pressure-temperature conditions which do not warrant steel valves. Valves can be installed horizontally, or vertically for upward flow.
- High-Strength Cast Iron Body and Cap conforms to ASTM A126, Class B.
- Solid Bronze Disc in 3" and smaller; Bronze-faced Iron Disc in 4" and larger
- Screwed-in Bronze Body Seat Ring
- Disc moves freely for maximum flow with minimum pressure drop. A disc stop, integral with the cap, prohibits the disc from sticking open when flow is reversed.
- ASME B16.1, ASME B16.10
- MSS SP-71 Type 1 and MSS SP-25

For more detailed features, refer to Page 30.

Figure 39E

Flanged - Bronze Trim

Size Range:

2 through 8 inches

Working Pressures Non-Shock

250 psi Steam, Basic Rating

500 psi Cold Working Pressure

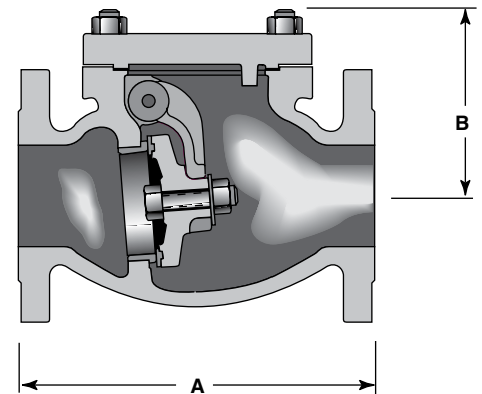

Principal Parts & Materials

Fig. No.	Size	Seating	End Conn.
39E	2" - 8"	Bronze	Flanged

Dimensions and Weights

Inches (millimeters) - pounds (kilograms)

Valves	2 (50)	2 ½ (65)	3 (80)	4 (100)	6 (150)	8 (200)
A	10.50 (267)	11.50 (292)	12.50 (318)	14.00 (356)	17.50 (445)	21.00 (533)
B	5.25 (133)	6.00 (152)	6.25 (159)	7.25 (184)	9.00 (229)	11.00 (279)
Wt.	46 (21)	64 (29)	90 (41)	133 (60)	250 (113)	410 (185)