

## Fig. 325 - Pipe Roller Chair

**Size Range** — 2" thru 24" pipe

**Material** — Cast iron and carbon steel

**Function** — For supporting pipe where movement may occur due to thermal expansion. Used when ceiling suspension is impractical

**Note** — When pipe line is insulated, total outside diameter of pipe and covering should be used to determine size of hanger; also see Figs. 260-1 to 265-4.

**Finish** — Plain

**Note** — Available in Electro-Galvanized and HDG finish or Stainless Steel materials.

**Order by** — Figure number, pipe size and finish

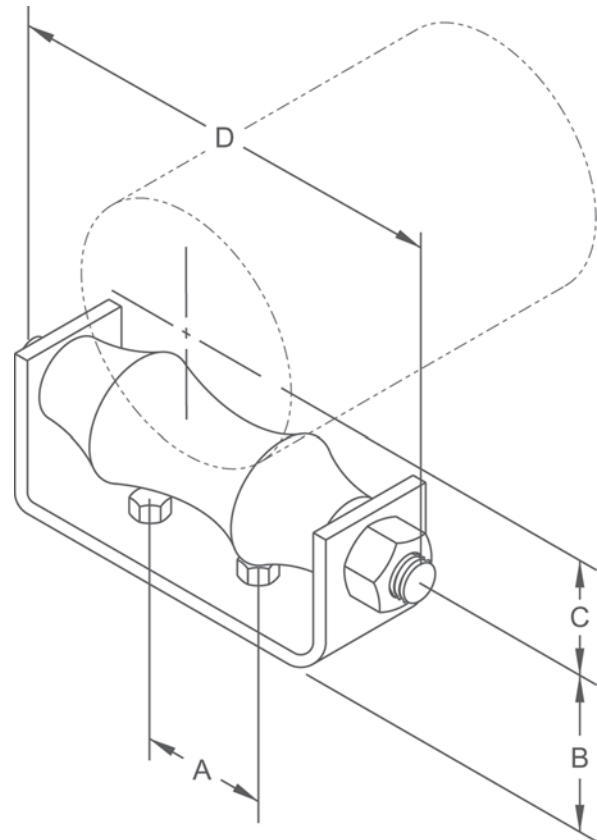

Dimensions • Weights							
Pipe Size	A	B	C	D	Bolt Size	Max. Rec. Load Lbs.	Approx. Wt./100
2	1¼	1½	1⅞	4	3/8 x 1½	600	104
2½	1¼	1⅞	1⅞	4½	3/8 x 1½	660	163
3	2	2	2⅜	5½	3/8 x 1½	700	175
3½	2	2⅝	2½	6	3/8 x 1½	750	245
4	2	2⅝	2⅝	6½	1/2 x 1¾	750	347
5	3	2⅞	3⅞	7½	1/2 x 1¾	750	488
6	3⅞	2¾	4¼	9	1/2 x 1¾	1070	613
8	3⅞	3⅞	5⅞	12⅞	5/8 x 1¾	1350	1039
10	5¼	3⅜	6⅞	14¾	5/8 x 2	1730	1654
12	5½	4⅞	7⅞	16⅞	5/8 x 2	2400	2190
14	6½	4⅞	8⅞	18¾	3/4 x 2	3130	2770
16	8¼	5⅞	9⅞	21	3/4 x 2½	3970	3460
18	9¼	6	10⅞	23⅞	3/4 x 2½	4200	4120
20	10¼	6½	11¾	24⅞	3/4 x 2½	4550	5510
24	12¼	7⅞	13⅞	29⅞	7/8 x 3½	6160	9000