

Class 300 • Union Cap • Bronze Disc • Threaded Ends

Features

- Lift Check Design
- Threaded Ends
- Union Cap
- For more detailed features, refer to page 47.

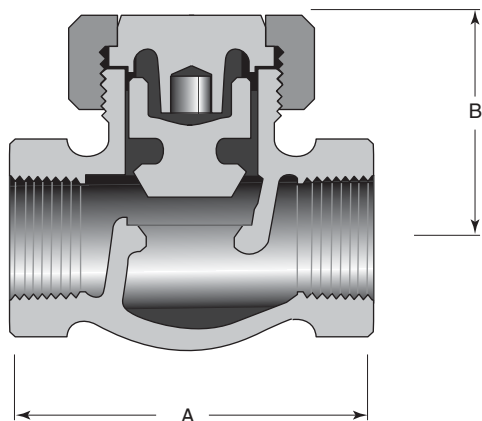

Figure 366E

Size Range:

½" through 2"

Working Pressures Non-Shock:

300 psi Steam, Basic Rating at 450° F
1000 psi Cold Working Pressure

Principal Parts & Materials

Part	Sizes	Material	ASTM
Body	All	Bronze	B62 alloy C83600
Disc	All	Bronze	B62 alloy C83600
Cap	½"	Bronze	B138 alloy C67500
Cap	¾" - 2	Bronze	B62 alloy C83600
Union ring	All	Bronze	B62 alloy C83600

Dimensions and Weights

Inches (millimeters) - pounds (kilograms)

	½ (15)	¾ (20)	1 (25)	1 ¼ (32)	1 ½ (40)	2 (50)
A	2.50 (64)	2.94 (75)	3.50 (89)	4.06 (103)	4.62 (117)	5.75 (146)
B	1.46 (37)	1.88 (48)	2.00 (51)	2.38 (60)	2.62 (66)	3.25 (83)
WTS.	1.0 (.45)	1.7 (.77)	2.6 (1.20)	4.1 (1.88)	5.6 (2.56)	10.0 (4.55)