

Class 125 • Inside Screw • Rising Stem • PTFE Disc • Threaded Ends

Features

- Rising Stem
- Bronze Disc
- Threaded Ends
- Internal Bronze Seat
- MSS SP-80, Type 1

For more detailed features, refer to page 7.

Figure 1702

Size Range:

¼" through 2"

Working Pressures Non-Shock:

125 psi Steam, Basic Rating

200 psi Cold Working Pressure

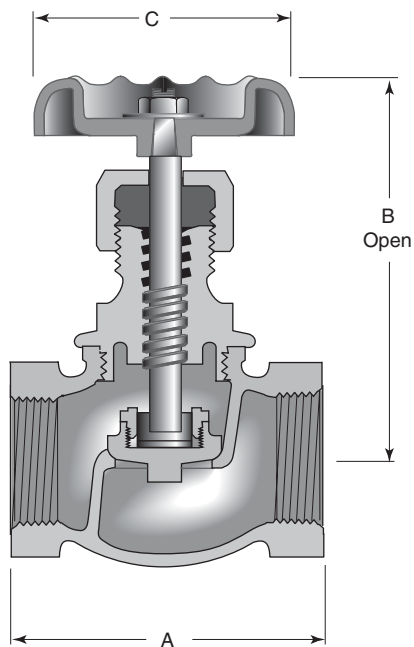

Principal Parts & Materials

Part	Sizes	Material	ASTM
Body	All	Bronze	B62 alloy C83600
Bonnet	All	Bronze	B62 alloy C83600
Disc	All	Bronze	—
Stem	All	Bronze	B21 alloy C48200

Dimensions and Weights

Inches (millimeters) - pounds (kilograms)

	¼ (6)	⅜ (10)	½ (15)	¾ (20)	1 (25)	1 ¼ (32)	1 ½ (40)	2 (50)
A	1.85 (47)	1.85 (47)	2.28 (58)	2.83 (72)	3.46 (88)	4.02 (102)	4.57 (116)	5.35 (136)
B	2.87 (73)	2.87 (73)	3.62 (92)	4.25 (108)	4.65 (118)	5.24 (133)	6.06 (154)	6.54 (166)
C	2.13 (54)	2.13 (54)	2.40 (61)	3.03 (77)	3.03 (77)	3.70 (94)	4.72 (120)	5.28 (134)
WTS.	0.70 (0.32)	0.70 (0.32)	0.96 (0.43)	1.43 (0.65)	2.15 (0.98)	3.20 (1.45)	4.18 (1.90)	4.78 (2.17)