

Class 150 • Union Cap • PTFE Disc • Threaded Ends

Figure 27TF

Size Range:

¼" through 2"

Working Pressures Non-Shock:

150 psi Steam, Basic Rating

300 psi Cold Working Pressure

Features

- Lift Check Design
- Threaded Ends
- Union Cap
- Disc holder is guided top and bottom on sizes ½" and larger
- PTFE disc
- MSS Specification SP-80

Note:

For horizontal installation only.

For more detailed features, refer to page 47.

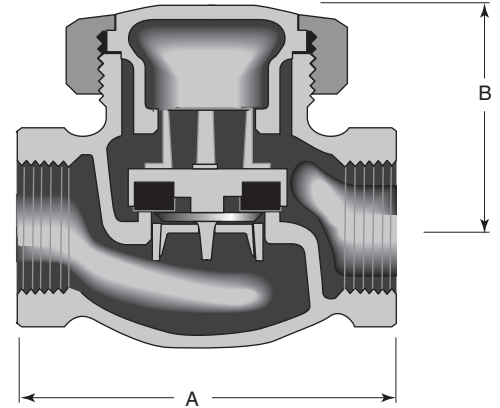

Principal Parts & Materials

| Part | Sizes | Material | ASTM |
|------------------------|-------|---------------------|------------------|
| Body, cap & union ring | All | Bronze | B62 alloy C83600 |
| Disc | All | PTFE w/metal holder | — |

Dimensions and Weights

Inches (millimeters) - pounds (kilograms)

| | ¼ (6) | ⅜ (10) | ½ (15) | ¾ (20) | 1 (25) | 1 ¼ (32) | 1 ½ (40) | 2 (50) |
|------|----------------|----------------|----------------|----------------|----------------|----------------|----------------|----------------|
| A | 1.96 (50) | 1.96 (50) | 2.62 (67) | 2.95 (75) | 3.50 (89) | 4.11 (104) | 4.59 (117) | 5.74 (146) |
| B | 1.32 (34) | 1.28 (33) | 1.56 (40) | 1.89 (48) | 2.29 (58) | 2.66 (68) | 2.87 (73) | 3.32 (84) |
| WTS. | 0.50 (0.23) | 0.50 (0.23) | 1.00 (0.43) | 1.50 (0.68) | 2.30 (1.04) | 3.60 (1.63) | 5.30 (2.38) | 8.90 (4.04) |