

Class 150 • Threaded Bonnet • Non-Rising Stem • Flanged Ends

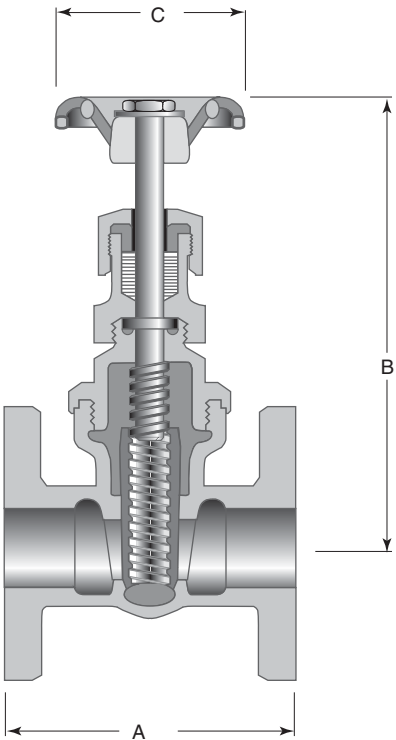

Features

- Screwed Bonnet
- Solid Wedge Disc
- Flanged Ends are plain faced with two V-shaped concentric grooves between the port and bolt holes.
- Full Ports
- Integral Bronze Seat
- MSS SP-80, Type 2

For more detailed features, refer to page 18.

Figure 429

Size Range:

1" through 3"

Working Pressures Non-Shock:

150 psi Steam, Basic Rating
225 psi Cold Working Pressure

Principal Parts & Materials

Part	Material	ASTM
Body & bonnet	Bronze	B62 alloy C83600
Disc	Bronze	B62 alloy C83600
Stem	Bronze	B371 alloy C69400

Dimensions and Weights

Inches (millimeters) - pounds (kilograms)

	1 (25)	1 ¼ (32)	1 ½ (40)	2 (50)	2 ½ (65)	3 (80)
A	3.94 (100)	4.33 (110)	4.72 (120)	5.32 (135)	6.50 (165)	7.28 (185)
B	4.88 (1.24)	5.71 (145)	6.50 (165)	7.44 (189)	9.19 (233)	10.38 (264)
C	2.56 (66)	2.75 (70)	3.06 (78)	3.62 (92)	4.06 (103)	4.75 (121)
WTS.	5.7 (2.6)	6.3 (2.85)	9.00 (4.06)	12.20 (5.51)	18.50 (8.36)	25.50 (11.52)