

**rotork<sup>®</sup>**  
**Fluid Systems**

**RCI200** Range

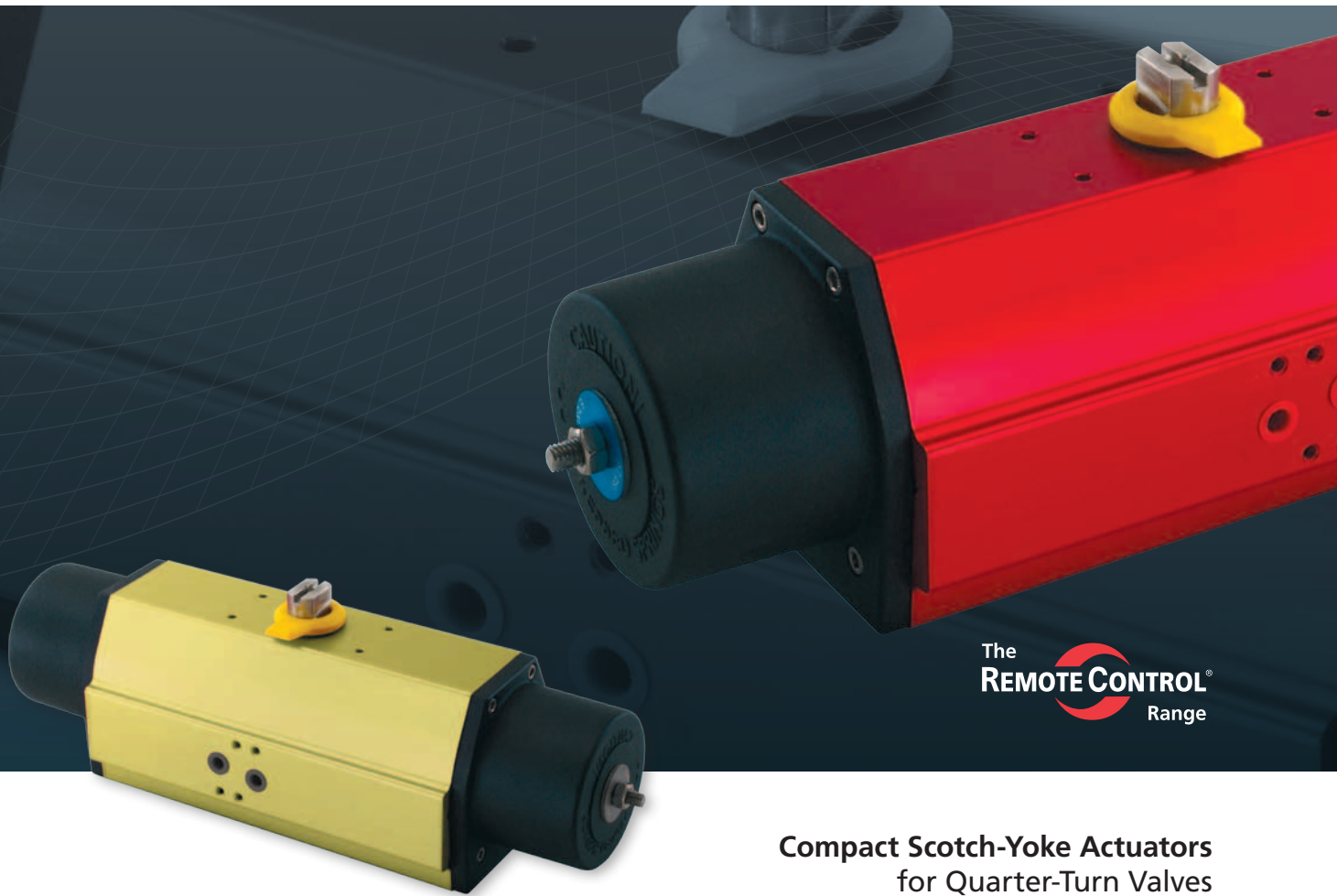

The  
**REMOTE CONTROL<sup>®</sup>**  
Range

**Compact Scotch-Yoke Actuators**  
for Quarter-Turn Valves

**Established Leaders in Actuation Technology**

## Rotork Actuators – Quality Controlled

Since the company was founded in 1957, Rotork has become the standard for excellence in the field of valve and damper automation for the oil, gas, power, water and waste treatment industries around the world.

As established leaders in actuation technology, we owe our success to a commitment to quality at every stage, and at every level, of Rotork's operations.

At the heart of the company is an exceptional workforce – the highly trained, forward thinking engineers, technicians, and sales support staff who each play a crucial role in maintaining Rotork's unrivaled reputation for innovation, reliability and first class after sale support.

With several fluid power factories and additional Centres of Excellence located around the globe, we are able to offer creative solutions and design systems for virtually any application – from subsea hydraulics to the most sophisticated yet simple fluid power control system.

Contact Rotork for your operational or safety application requirements. We will work with you from conception, to design, to manufacture, to installation, and finally to maintenance and service support.



## Remote Control Range RCI200 Compact Scotch-Yoke Actuators

The Rotork Fluid Systems RCI200 pneumatic actuator features a modern scotch-yoke mechanism that provides high start- and end-torque output in a very compact package. It is available in both double-acting and spring-return configurations with an optional integral manual override. Spring-return actuators feature springs that are safely contained within an epoxy coated cartridge. Pistons are guided in two places by high-performance bearings which ensure proper alignment and long seal life. Adjustable travel stops are available in both directions.

RCI200 actuators have the lowest weight and the smallest external dimensions of any actuator with an equivalent torque output. This yields a compact and light yet robust valve / actuator package, particularly when a manual override solution is required. Another benefit is that they have less stroke volume than comparable rack and pinion actuators, providing a significant saving in the use of compressed air.

### Quality

RCI200 actuators are manufactured under strict quality control in an ISO 9001 / 14000 environment. They comply with all standard international requirements and are CE marked according to PED and ATEX. We use only top-quality materials in a precisely engineered and manufactured product so our actuators are very long lasting. We are proud to provide a unique three-year warranty.

### Efficiency

Unlike rack & pinion designs often offered by our competitors, the RCI200 with its scotch-yoke drive gives at least 50% more torque in the end positions, where most valves require it.

### Reliability

Every Rotork Fluid Systems actuator is built to provide long and efficient service with a minimum of maintenance. The design, engineering and materials used in their construction ensure optimum performance even in the harshest of environments.

# Inside The RCI200 Actuator

<b>Operating Pressure:</b>	30-145 psi	(2-10 bar)
<b>Torque Output:</b>	Up to 39,000 lbf-in	(4,400 Nm)
<b>Temperature Ranges:</b>		
Standard:	-4 to +175 °F	(-20 to +80 °C)
High:	+32 to +300 °F	(0 to +150 °C)
Low:	-40 to +140 °F	(-40 to +60 °C)
Arctic:	-52 to +140 °F	(-47 to +60 °C)

### Extra Corrosion Protection:

RCT: hard anodise / low friction polymer treatment.  
 Epoxy coating.  
 Offshore or other finish to meet customer specifications.  
 Stainless screws and drive shaft (standard for RCI210 – 260).

### Standards:

Solenoid valve connection: NAMUR.  
 Fitting accessories: VDI/VDE 3845, NAMUR.  
 Fitting to valve: Hole pattern, centering ring ISO 5211, DIN 3337, NAMUR.  
 Stardrive shaft: ISO 5211 with 90° □ and DIN 79 with 45° ◇ and NAMUR.

Certified suitable for use at SIL 2 & SIL 3 as a single device in accordance with IEC 61508.

### Operating Medium:

Air, inert gases (non-dangerous fluids, group 2 according to directive PED 97/23/EC).

RCI200 actuators also available for water or oil hydraulics.

**CE Marking:** CE marked according to PED and ATEX.

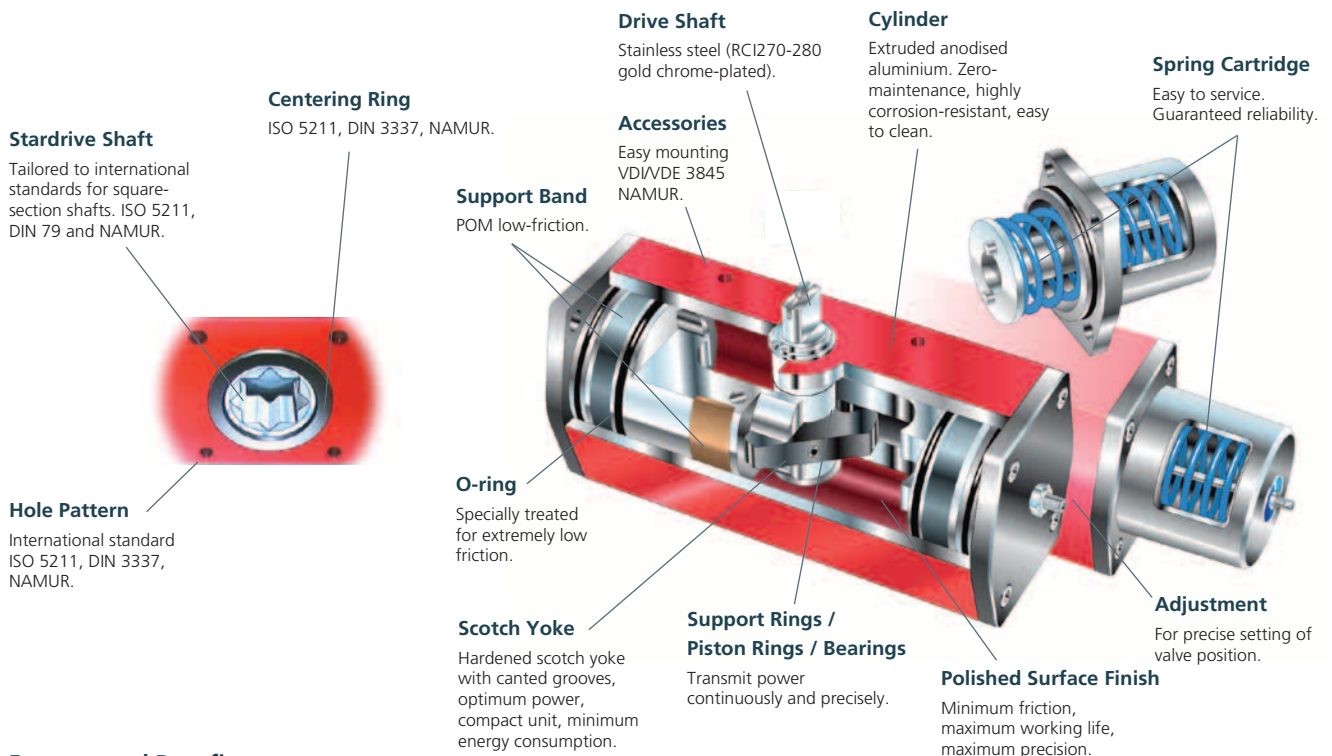

### Features and Benefits

- For either on/off and modulating applications.
- Lightweight, compact design.
- Double-acting and spring-return configurations.
- Pre-tensioned springs for safety.
- High torque in the end-of-stroke positions.
- Connections and mounting according to international standards.
- High efficiency, low air consumption.
- Housing in anodised aluminium.

### Note on the RCI265

The RCI265 size is an addition to the 200 series actuator family. This model was added as an optimum solution to a torque gap between the 260 and 270 sizes. It incorporates all the standard features of the RCI200 series except that it is available only in standard and high temperature builds. An added feature unique to the 265 model is adjustable limit stops that allow ±4° adjustment of both open and close positions. An external stop cam can be custom machined for different degrees of rotation.

# Rotork Actuators – Quality Controlled



RCI240-SR M1

## Compact Declutchable Handwheel

The override is integrated in the endcap of the actuator and can be fitted to all RCI200 series units in both double-acting and spring-return configurations. The RC M1 manual override is the optimum solution for users requiring a compact unit of minimum weight and size.

- For both double-acting and spring-return actuators.
- Lightweight yet rugged design.
- Safe, non-rotating handwheel, eliminates use of levers for manual operation.
- Valve/actuator can be locked in either open or close position.
- Can serve as an adjustable travel stop in either direction.



RCI280-SR M1  
With control accessories

See the comparison below of an RCI200 M1 with a rack and pinion actuator equipped with an intermediate gearbox providing the override function.

Note that the installed height of an RCI200-DA with M1 override is the same as an RCI200 actuator without manual override and is significantly less than that of an actuator/gearbox solution.

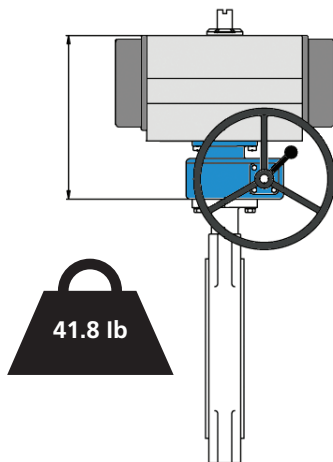

Rack & pinion actuator with intermediate gearbox

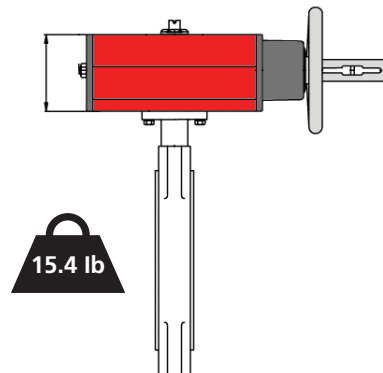

RCI240-DA M1

# Fitting Accessories

## The Right Accessory Solutions

Valves and actuators only perform as well as the solution is engineered. With decades of experience engineering fluid power valve automation for a multitude of applications and markets, you can depend on Rotork to provide a reliable and safe automation solution to meet your requirements.

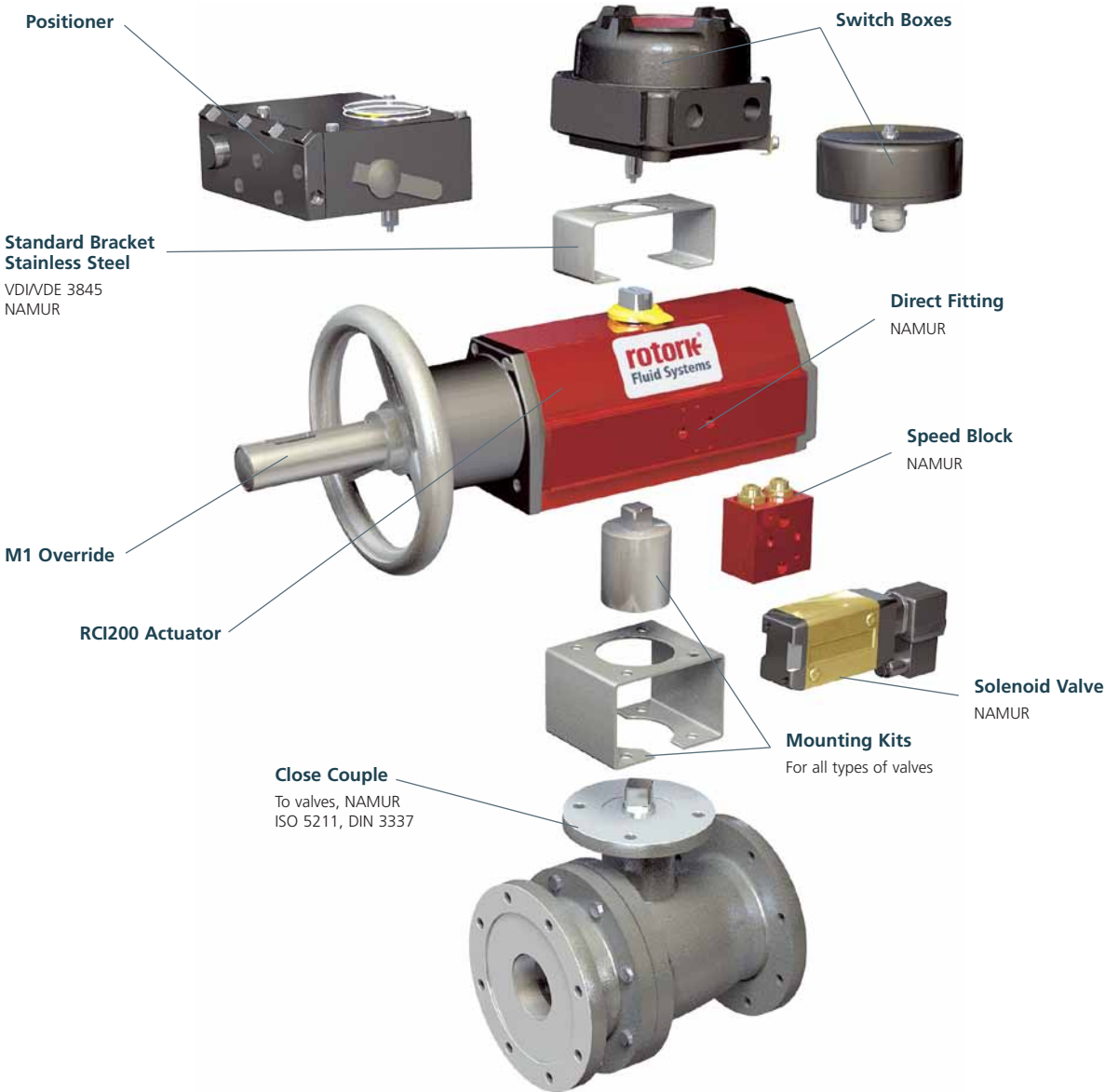



# RCI200 Dimensions

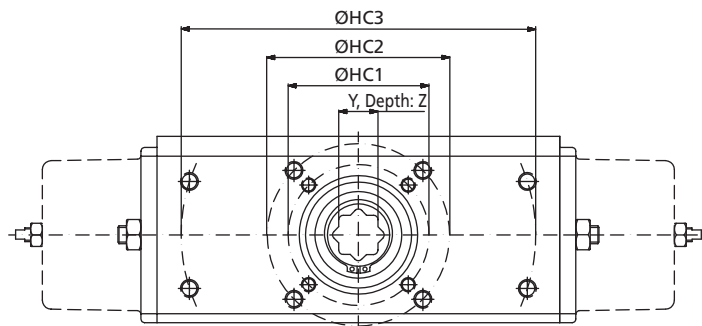

Fig. 1

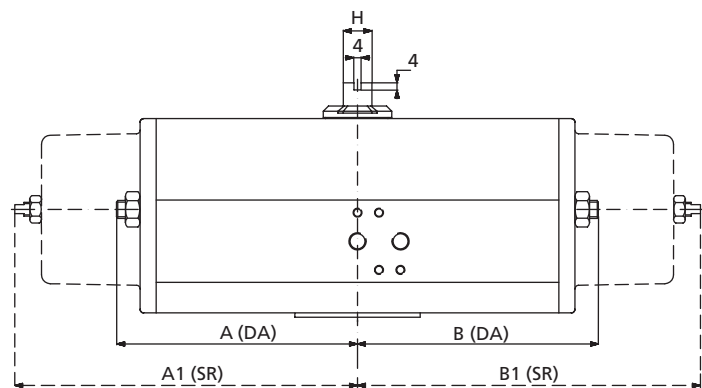

Fig. 2

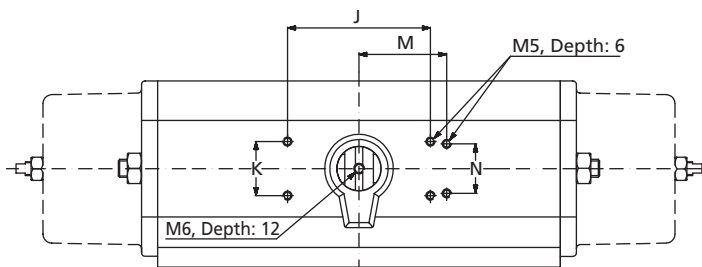
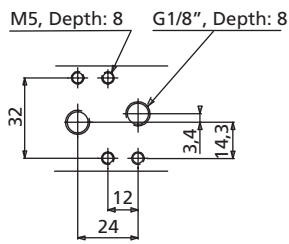

Fig. 3

Model	Dimensions (inch)																				Weight (lbs)	
	Fig. 1					Fig. 2				Fig. 3				Fig. 4/4a								
	HC 1	HC 2	HC 3	Y**	Z	A	B	A1	B1	H	J	K	M	N	C	E	F	G	U*	V	DA	SR
RCI210	F05	F07	-	.551/.553	.75	1.77	3.85	1.77	5.70	.393	1.39	1.39	1.574	1.18	1.26	1.61	2.95	.630	1.378	.078	3.1	4.0
RCI220	F05	F07	-	.551/.553	.75	3.85	3.85	5.91	5.91	.393	3.15	1.18	-	-	1.26	1.61	2.95	.630	1.378	.078	4.0	5.8
RCI230	F07	F10	-	.669/.672	1.18	2.56	5.30	2.56	7.87	.629	3.15	1.18	-	-	1.93	2.17	4.25	.984	2.165	.118	8.0	10.4
RCI240	F07	F10	-	.866/.869	1.18	5.30	5.30	7.70	7.70	.629	3.15	1.18	-	-	1.93	2.17	4.25	.984	2.756	.118	10.6	15.5
RCIO250	F10	F12	-	.866/.869	1.46	3.54	7.48	3.54	11.22	.944	3.15	1.18	-	-	2.72	2.95	6.10	1.378	2.756	.118	20.4	26.8
RCIO260	F10	F12	-	1.063/1.066	1.46	7.48	7.48	11.22	11.81	.944	3.15	1.18	-	-	2.72	2.95	6.10	1.378	3.346	.118	28	40
RCI265	F12	-	-	1.063/1.066	1.46	7.68	7.68	12.48	12.48	.866	3.15	1.18	-	-	2.99	2.99	7.95	1.378	3.346	.118	42	59
RCIO270	F14	-	6.69 x 4.33	1.417/1.420	2.52	5.70	11.60	5.70	20.08	1.574	5.12	1.18	-	-	4.33	4.33	9.76	2.362	3.937	.157	69	100
RCIO280	F12	F16	9.24 x 3.82	1.812/1.815	2.52	11.80	11.60	20.08	20.87	1.574	5.12	1.18	-	-	4.33	4.33	9.76	2.362	5.118	.197	107	142

# RCI200 Dimensions

## RCI210 to 240



Hole pattern for solenoid valves acc. to VDI/VDE 3845, NAMUR

## RCI250 to 280

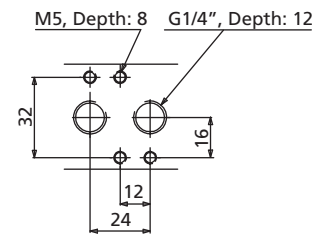

## RCI210 to 265

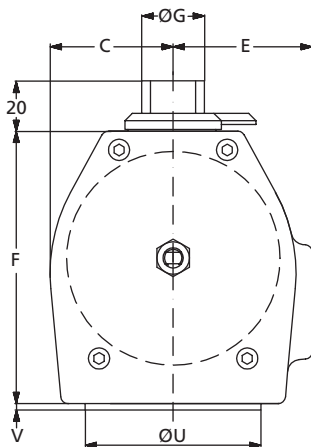

Fig. 4

## RCI270 to 280

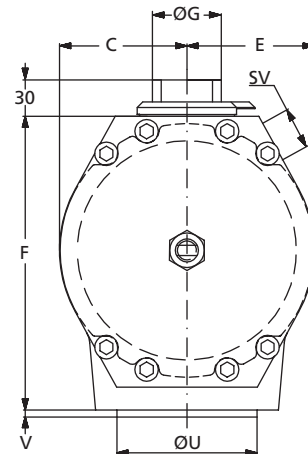

Fig. 4a

SV = Mounting solenoid valves acc. to VDI/VDE 3845, NAMUR

U+V = Guide ring acc. to DIN 3337

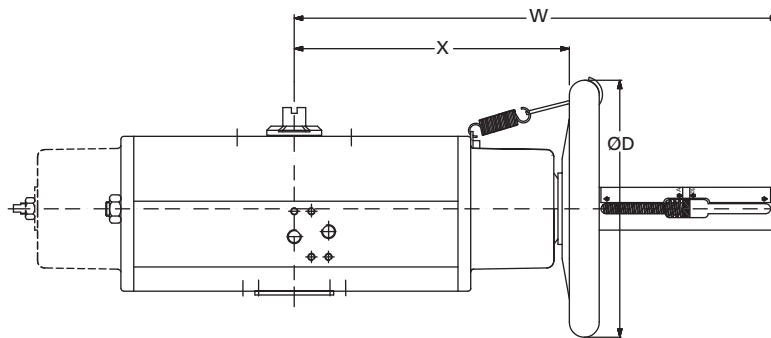

Fig. 5

Model	Dimensions (inch)			Weight w/M1(lbs)	
	D	X	W	DA	SR
RCI210	7.1	5.7	11.4	4.9	5.5
RCI220	7.1	5.7	11.4	6.0	7.0
RCI230	7.1	7.5	13.4	10.6	11.7
RCI240	7.1	7.5	13.4	12.8	15.7
RCIO250	12.6	11.6	19.7	30.4	33.5
RCIO260	12.6	11.6	19.7	36.0	44.5
RCI265	12.6	14.6	19.7	53.6	68.3
RCIO270	15.8	20.3	31.5	104	127
RCIO280	23.6	19.3	31.5	121	192

U\* = Guide ring for other hole circle on request.

Y\*\* = Tolerance H9. The hole is octagonal and adapts to valve stems with squares at either 90° (ISO 5711) or 45° (DIN 3337) orientations.

Hole Dimensions (inch)			
ISO 5211	Circle Ø	Thread	Depth
F05	1.97	1/4-20	.43
F07	2.76	5/16-18	.55
F10	4.02	1/2-13	.67
F12	4.92	3/8-16	.83
F14	5.51	5/8-11	.98
F16	6.50	3/4-10	1.26
170 x 110	-	5/8-11	.98
234.7 x 97.2	10.00	5/8-11	.98

# RCI200 Dimensions

## Air Consumption DA

Model	Free Air at 87 psi (Litres)	
	Anti-clockwise rotation	Clockwise rotation
RCI210	0.6	1.1
RCI220	1.1	1.3
RCI230	2.2	4
RCI240	4.4	5
RCIO250	6.9	13
RCIO260	13.8	16
RCI265	32	36
RCIO270	33	54
RCIO280	66	67

## Air Consumption SR

Model	Free Air at 87 psi (Litres)
	RC210
RC220	1.3
RC230	4
RC240	5
RC250	13
RC260	16
RC265	36
RC270	54
RC280	67

## Operation Times DA/SR

Model	Time at 87 psi (sec)
	Anti-clockwise and Clockwise rotation
RC210	<0.3
RC220	<0.3
RC230	<0.6
RC240	<0.7
RC250	<2.5
RC260	<2.5
RC265	<1.5
RC270	<5
RC280	<5

The times relate to full air flow and may increase depending on solenoid valves and the dimensions of connecting pipes.

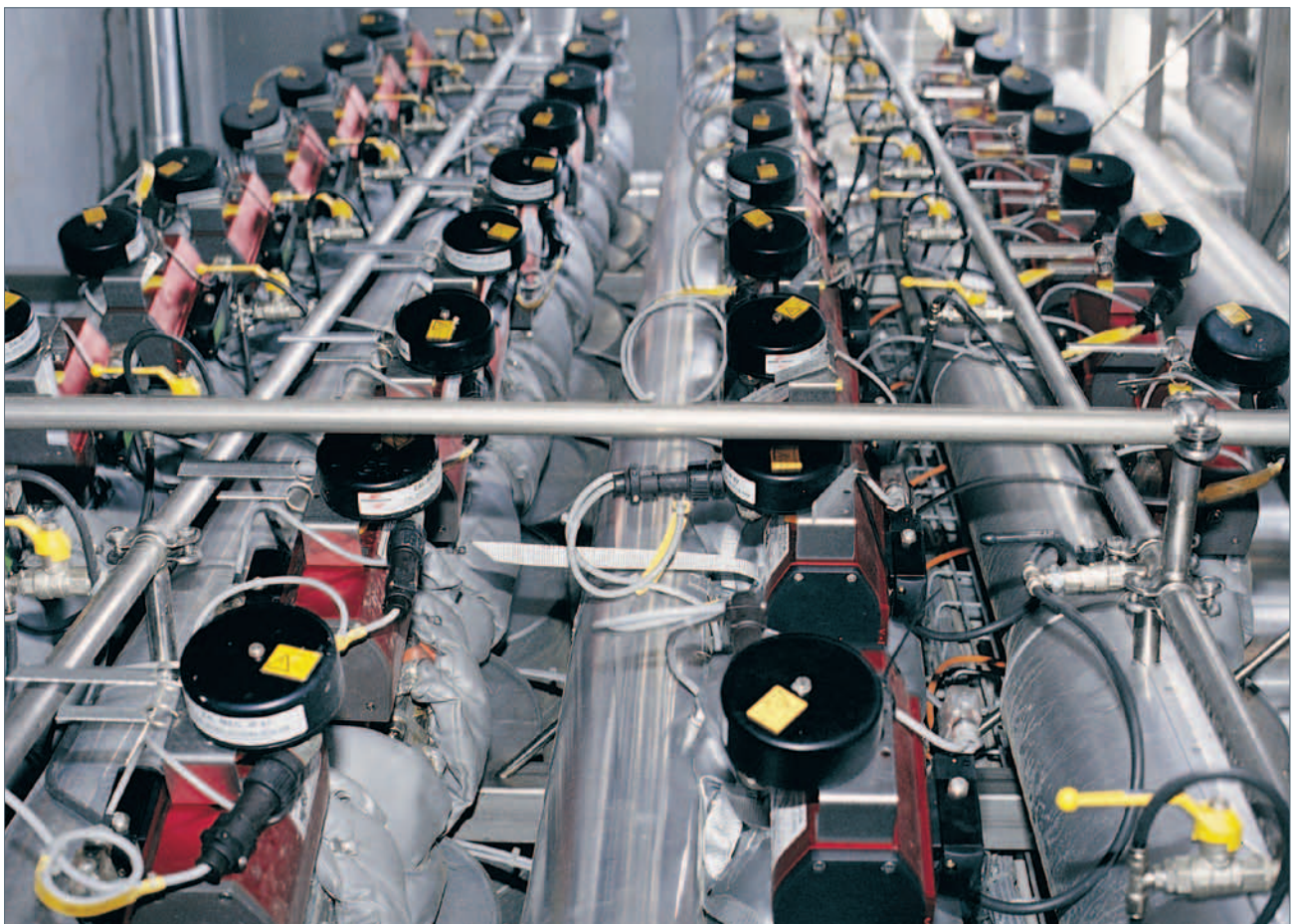



# Torque Data – Double-Acting

## RCI200-DA

Model	Function	Position	Output Torque (lbf-in)*							
		0° = closed 90° = open	2.1 bar 30 psi	2.8 bar 40 psi	3.5 bar 50 psi	4.2 bar 60 psi	4.5 bar 65 psi	5.5 bar 80 psi	6 bar 87 psi	7 bar 100 psi
RCI210	Air open/close	0°	115	150	186	221	239	310	336	389
		60°	53	71	89	106	115	150	168	195
		90°	80	106	133	159	168	221	239	283
RCI220	Air open/close	0°	230	301	372	451	487	620	673	779
		60°	115	150	186	221	239	310	336	389
		90°	159	212	266	319	345	443	478	558
RCI230	Air open/close	0°	425	566	708	850	912	1,177	1,283	1,460
		60°	212	274	345	416	443	584	637	735
		90°	310	407	504	611	655	850	929	1,062
RCI240	Air open/close	0°	867	1,151	1,434	1,726	1,850	2,354	2,567	3,009
		60°	434	575	717	859	920	1,177	1,283	1,505
		90°	620	823	1,036	1,239	1,328	1,708	1,859	2,124
RCIO250	Air open/close	0°	1,328	1,770	2,213	2,655	2,841	3,655	3,983	4,691
		60°	664	885	1,106	1,328	1,425	1,823	1,991	2,301
		90°	956	1,266	1,584	1,903	2,036	2,593	2,832	3,363
RCIO260	Air open/close	0°	2,699	3,602	4,496	5,399	5,788	7,382	8,054	9,470
		60°	1,328	1,770	2,213	2,655	2,841	3,735	4,071	4,691
		90°	1,947	2,593	3,248	3,894	4,169	5,275	5,753	6,815
RCI265	Air open/close	0°	3,824	5,098	6,373	7,647	8,196	10,515	11,471	13,382
		60°	1,797	2,399	2,992	3,593	3,850	4,921	5,364	6,293
		90°	2,717	3,620	4,532	5,434	5,824	7,470	8,152	9,515
RCIO270	Air open/close	0°	5,576	7,435	9,293	11,152	11,949	15,338	16,728	19,472
		60°	2,788	3,717	4,647	5,576	5,974	7,629	8,320	9,736
		90°	4,027	5,372	6,709	8,054	8,629	11,037	12,037	14,073
RCIO280	Air open/close	0°	11,240	14,984	18,737	22,481	24,083	30,827	33,633	39,386
		60°	5,620	7,497	9,364	11,240	12,046	15,418	16,816	19,649
		90°	8,098	10,798	13,497	16,197	17,356	22,233	24,251	28,234

\* Output torque +/- 5%.



# Torque Data – Spring-Return (spring to close)

## RCI200-SR

Model	Function	Position	Output Torque (lbf-in)*							
		0° = closed 90° = open	2.1 bar 30 psi	2.8 bar 40 psi	3.5 bar 50 psi	4.2 bar 60 psi	4.5 bar 65 psi	5.5 bar 80 psi	6 bar 87 psi	7 bar 100 psi
RCI210	Air	0°	62	80	106	124	133	168	177	212
		60°	27	35	44	53	53	71	80	89
		90°	35	44	53	66	71	89	97	115
	Spring	90°	53	71	89	106	115	142	159	186
		30°	27	35	44	53	53	71	80	89
		0°	35	53	62	75	80	97	106	124
RCI220	Air	0°	133	168	212	257	274	345	363	425
		60°	53	71	89	106	115	142	159	186
		90°	71	89	106	133	142	177	195	230
	Spring	90°	115	150	186	221	239	292	327	381
		30°	53	71	89	106	115	142	159	186
		0°	80	97	124	150	159	204	221	257
RCI230	Air	0°	239	319	398	478	513	637	690	814
		60°	106	133	168	204	221	274	292	345
		90°	133	168	212	257	274	345	363	425
	Spring	90°	212	274	345	416	451	558	611	717
		30°	106	133	168	204	221	274	292	345
		0°	150	195	239	292	319	389	416	487
RCI240	Air	0°	487	646	814	974	1,053	1,301	1,398	1,637
		60°	212	274	345	416	451	558	602	708
		90°	257	345	425	513	558	682	743	867
	Spring	90°	425	566	708	850	920	1,133	1,239	1,443
		30°	212	274	345	416	540	558	602	708
		0°	292	389	487	584	628	779	850	1,018
RCIO250	Air	0°	752	1,000	1,257	1,505	1,629	2,009	2,168	2,567
		60°	327	434	549	655	708	876	929	1,106
		90°	398	531	664	797	859	1,062	1,151	1,372
	Spring	90°	664	885	1,106	1,328	1,434	1,770	1,903	2,257
		30°	327	434	549	655	708	876	929	1,106
		0°	443	593	735	885	956	1,177	1,328	1,549
RCIO260	Air	0°	1,531	2,036	2,540	3,054	3,310	4,071	4,425	5,133
		60°	664	885	1,106	1,328	1,434	1,770	1,903	2,213
		90°	797	1,062	1,328	1,593	1,726	2,124	2,345	2,744
	Spring	90°	1,354	1,797	2,248	2,699	2,921	3,602	3,894	4,558
		30°	664	885	1,106	1,328	1,434	1,770	1,903	2,213
		0°	929	1,239	1,549	1,859	2,009	2,478	2,699	3,098
RCI265	Air	0°	2,478	3,301	4,133	4,956	5,372	5,939	6,461	8,275
		60°	1,000	1,328	1,655	1,991	2,160	2,478	2,699	3,186
		90°	1,106	1,478	1,841	2,213	2,399	2,682	2,921	3,762
	Spring	90°	1,859	2,478	3,098	3,717	4,027	4,956	5,399	6,151
		30°	912	1,213	1,513	1,814	1,965	2,416	2,921	3,142
		0°	1,354	1,797	2,248	2,699	2,921	3,602	3,894	4,647
RCIO270	Air	0°	3,142	4,186	5,240	6,284	6,806	8,382	9,116	10,709
		60°	1,372	1,832	2,283	2,744	2,974	3,655	3,894	4,602
		90°	1,682	2,239	2,806	3,363	3,647	4,487	4,868	5,664
	Spring	90°	2,788	3,717	4,647	5,576	6,036	7,435	8,054	9,382
		30°	1,372	1,832	2,283	2,744	2,974	3,655	3,894	4,602
		0°	1,903	2,540	3,169	3,806	4,124	5,071	5,487	6,373
RCIO280	Air	0°	6,328	8,435	10,550	12,657	13,710	16,878	18,410	21,507
		60°	2,744	3,655	4,576	5,487	5,948	7,320	7,966	9,293
		90°	3,363	4,487	5,603	6,727	7,284	8,966	9,824	11,417
	Spring	90°	5,620	7,497	9,364	11,240	12,179	14,984	16,285	19,029
		30°	2,744	3,655	4,576	5,487	5,948	7,320	7,966	9,293
		0°	3,850	5,133	6,417	7,700	8,337	10,267	11,152	13,011

\* Output torque +/- 5%.

Note: Springs adapted to air supply pressure.

# Torque Data – Spring-Return (spring to open)

## RCI200-SRF

Model	Function	Position	Output Torque (lbf-in)*							
		0° = closed 90° = open	2.1 bar 30 psi	2.8 bar 40 psi	3.5 bar 50 psi	4.2 bar 60 psi	4.5 bar 65 psi	5.5 bar 80 psi	6 bar 87 psi	7 bar 100 psi
RCI210	Spring	0°	62	85	106	133	142	177	186	221
		60°	23	32	41	49	53	66	69	80
		90°	27	38	49	58	62	80	89	102
	Air	90°	46	64	80	97	106	133	143	168
		45°	25	34	43	53	57	71	80	89
		0°	40	55	71	89	89	115	127	152
RCI220	Spring	0°	124	177	221	266	292	363	381	443
		60°	47	64	80	97	106	133	137	159
		90°	59	80	106	124	133	168	177	204
	Air	90°	97	124	159	195	212	266	292	336
		45°	50	68	87	106	115	142	159	190
		0°	83	115	142	177	195	239	266	305
RCI230	Spring	0°	239	327	416	504	549	682	743	823
		60°	87	115	150	186	204	248	266	292
		90°	106	142	186	221	239	301	336	354
	Air	90°	186	257	327	389	425	531	549	664
		45°	97	133	168	204	221	274	292	363
		0°	150	204	257	319	345	425	456	584
RCI240	Spring	0°	496	682	867	1,044	1,151	1,416	1,593	1,682
		60°	177	239	310	372	407	504	575	602
		90°	221	301	381	460	496	620	708	726
	Air	90°	372	513	646	788	859	1,062	1,089	1,372
		45°	195	274	345	416	460	566	584	743
		0°	310	425	540	655	717	885	859	1,195
RCIO250	Spring	0°	743	1,018	1,283	1,549	1,726	2,124	2,345	2,699
		60°	266	372	469	566	620	770	850	991
		90°	327	443	566	690	752	929	1,062	1,151
	Air	90°	575	788	974	1,195	1,328	1,637	1,726	1,991
		45°	301	416	531	646	699	867	920	1,089
		0°	478	655	867	1,018	1,106	1,372	1,416	1,726
RCIO260	Spring	0°	1,549	2,124	2,655	3,275	3,540	4,425	4,779	5,487
		60°	558	761	974	1,195	1,283	1,593	1,726	1,947
		90°	682	929	1,195	1,416	1,549	1,947	2,168	2,478
	Air	90°	1,195	1,637	2,832	2,478	2,496	3,408	3,540	4,116
		45°	620	850	1,062	1,328	1,310	1,770	1,859	2,213
		0°	974	1,328	1,682	2,036	1,956	2,788	2,921	3,496
RCI265	Spring	0°	2,222	2,965	3,708	4,425	4,744	5,930	6,461	7,523
		60°	814	1,089	1,363	1,549	1,664	2,036	2,301	2,655
		90°	1,000	1,328	1,664	1,991	2,133	2,655	2,876	3,319
	Air	90°	1,664	2,213	2,770	3,319	3,558	4,425	4,647	5,487
		45°	894	1,195	1,496	1,770	1,894	2,301	2,567	2,965
		0°	1,398	1,859	2,328	2,788	2,992	3,540	3,939	4,647
RCIO270	Spring	0°	3,098	4,248	5,487	6,638	7,169	8,939	9,736	11,063
		60°	1,151	1,549	19,649	2,390	2,567	3,231	3,540	3,983
		90°	1,372	1,859	2,390	2,832	3,098	3,894	4,248	4,868
	Air	90°	2,390	3,275	4,160	5,045	5,487	6,815	7,346	8,851
		45°	1,283	1,726	2,213	2,655	2,921	3,629	3,806	4,779
		0°	2,036	2,744	3,452	4,248	4,602	5,709	6,019	7,169
RCIO280	Spring	0°	6,461	8,851	11,240	13,630	14,781	18,410	19,914	22,127
		60°	2,301	3,186	4,071	4,868	5,310	6,638	6,904	7,258
		90°	2,832	3,894	4,956	6,019	6,550	8,143	8,851	9,736
	Air	90°	4,956	6,815	8,674	10,444	11,417	14,161	15,046	17,702
		45°	2,567	3,540	4,514	5,487	5,930	7,390	7,966	9,736
		0°	4,071	5,576	7,125	8,674	9,382	11,683	12,214	15,046

\* Output torque +/- 5%.

Note: Springs adapted to air supply pressure.



Electric Actuators and Control Systems  
Fluid Power Actuators and Control Systems  
Gearboxes and Gear Operators  
Projects, Services and Retrofit



Corporate headquarters  
Rotork plc  
tel +44 (0)1225 733200  
fax +44 (0)1225 333467  
email mail@rotork.com

A full listing of our worldwide sales and service network is available on our website.

[www.rotork.com](http://www.rotork.com)

PUB014-002-00  
Issue 06/11

All Rotork Fluid Systems actuators are manufactured under a third party accredited ISO9001 quality assurance programme.

Published and produced by Rotork Fluid Systems.

Rotork recognises all registered trademarks. As we are continually developing our products, their design is subject to change without notice. POWTG0611