

rotork®

Gears

IS Multi-turn

Cast Iron Housing Gearboxes

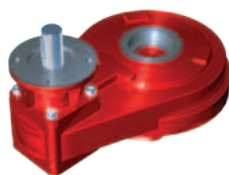
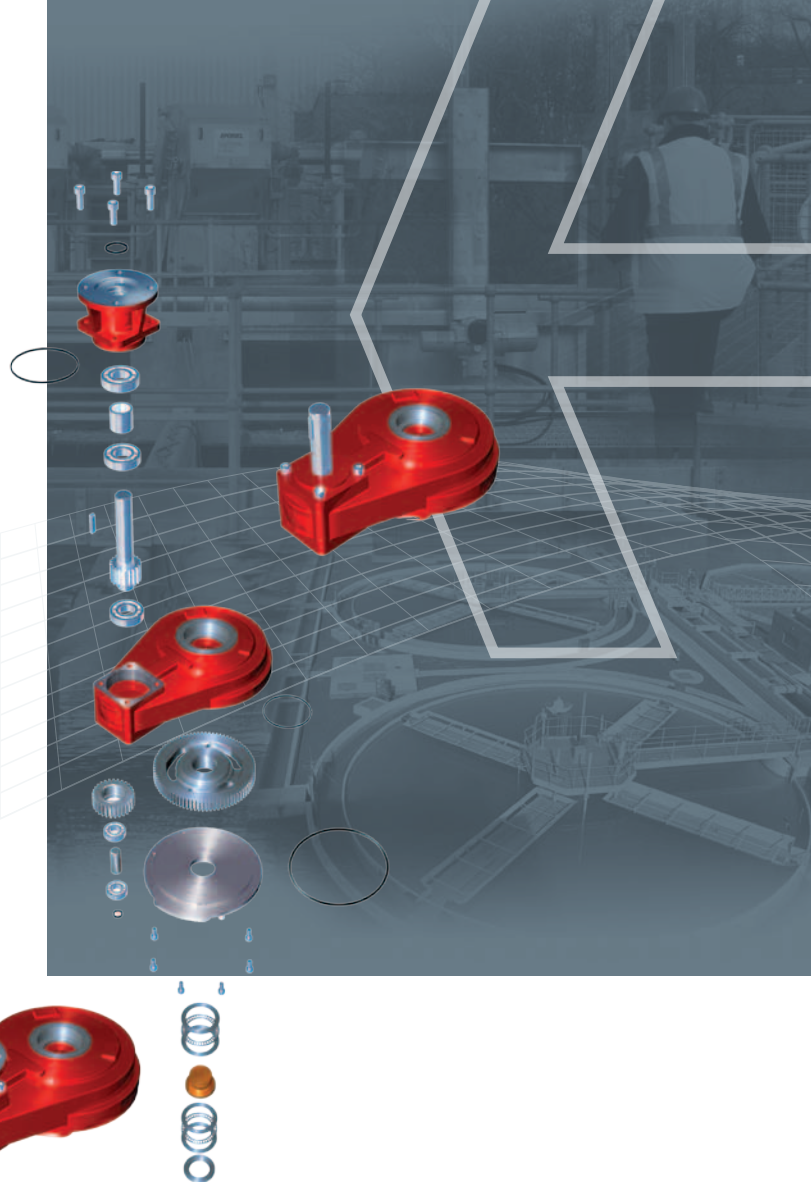

IS Multi-turn Gearbox Series

The IS series of multi-turn operators has been designed with customer stocking in mind, and features a removable output sleeve to facilitate spindle machining.

Operating temperature normally ranges from -40 to 250 °F, although other temperature ranges are available on request.

Standard input (for actuation) and output flanges are to MSS SP-102. However, equivalent standards such as ISO can be supplied.

Application

Rotork Gears IS series operators are Multi-turn devices intended for the operation of gate, globe, sluice and penstock valves. The gearboxes are suitable for manual and motorised applications.

Environmental Specification

Enclosure IP67 standard suitable for submerged duty up to a depth of 1 metre for 30 minutes.

Enclosure IP68 continuous submerged duty up to a maximum depth of 15 metres.

Features

- Totally enclosed gearing
- Grease filled for life & fully sealed
- Comprehensive gear ratios
- Removable output sleeve
- Spur and bevel combinations available
- Input gear mounted on ball bearings

Options

- Upward or downward oriented input
- Auxiliary spur / bevel input reducers
- Input flanges for motorisation
- Two speed spur input reducers
- High & low temperatures
- Padlockable handwheels
- Nuclear
- IP68
- Buried duty
- Raw sewage
- Mechanical Dial Position Indicator
- Flexible Extensions
- Emergency fire duty e.g. to ISO 10497

Established Leaders in Actuation Technology

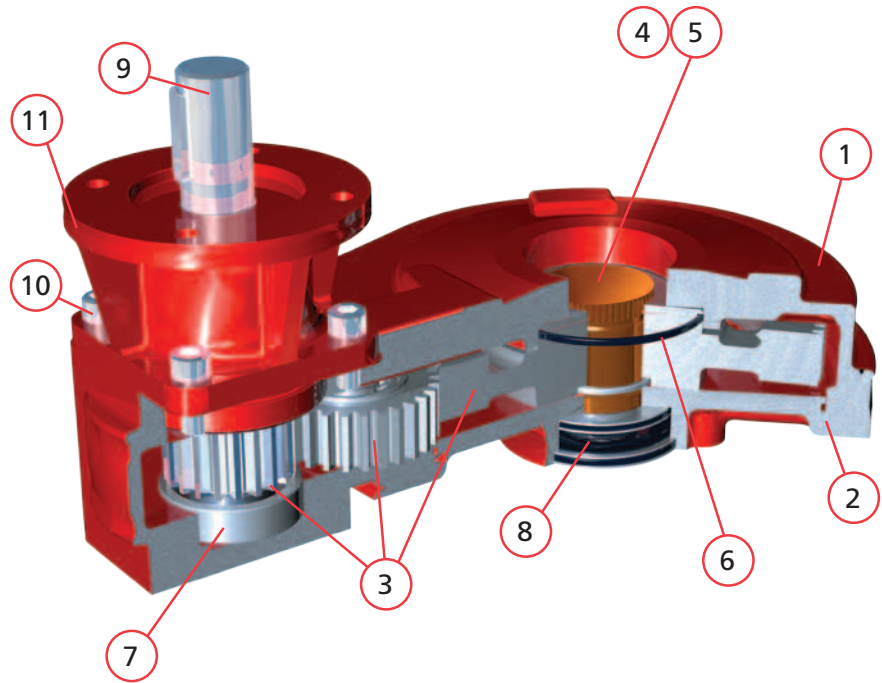

Material specification for Rotork Gear IS Range of SPUR Gear Valve Operators

No.	Description	Material	USA Standard
1	Gearcase (IS2 to IS7 & IS12 to IS14)	Cast Iron	ASTM A48 35B/40B
	Gearcase (IS8 to IS11 & IS15 to IS20)	SG Iron	ASTM A536 65-45-12
2	Baseplate	SG Iron	ASTM A536 65-45-12
3	Gears	SG Iron Steel	AISI/SAE 1010 or 4340
4	Output Sleeve A1	Steel	ASIS/SAE 1023
5	Output Sleeve A2	Aluminium Bronze	ASTM B505 C95800
6	Seals	Nitrile Rubber	
7	Input Shaft bearings	Ball Bearings	
8	Output Thrust Bearings	Needle Roller Bearings (with the exception of output sizes 14, 16, 18, 19 & 20 which has Roller Thrust Bearings).	
9	Input Shaft	Steel	AISI/SAE 4340
10	Fasteners	Steel	
11	Input Housing	Cast Iron	ASTM A48 35B/40B
	Grease	Renolit CL-X2	
	Finish	PE3 Grey Primer (other finishes available on request)	

Note: Because of the company's policy of continuous improvement, Rotork Gears reserves the right to change specification details without prior notice.

IS Multi-turn

Cast Iron Housing Gearboxes

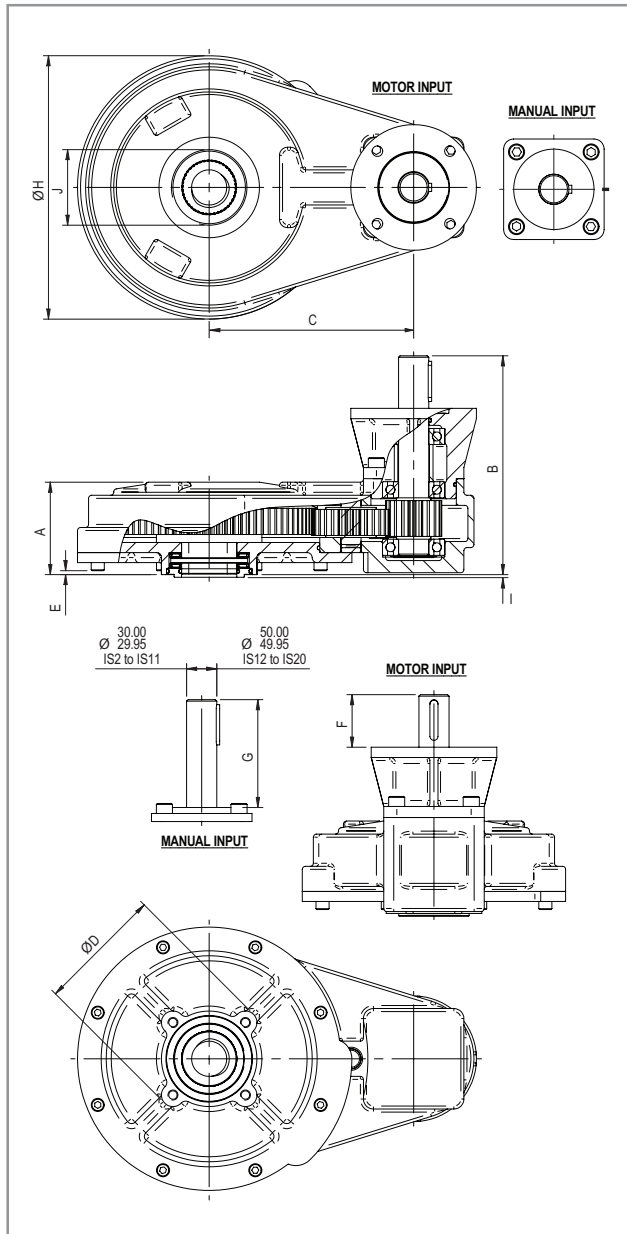

Input Flange Details

Input	Flange Dia. & Thickness	Shaft Dia.	Key Details
F10 & FA10	Ø4.92 x 0.39	0.787 - 0.002	0.236 x 0.236 x 1.575
F14 & FA14	Ø6.89 x 0.59	1.181 - 0.002	0.315 x 0.276 x 1.575
F16 & FA16	Ø8.27 x 0.79	*1.575 - 0.002	**0.472 x 0.315 x 2.165
F25 & FA25	Ø11.18 x 0.79	1.968 - 0.002	0.551 x 0.354 x 2.165
F30	Ø13.78 x 0.79	1.968 - 0.002	0.551 x 0.354 x 3.150
ROTORK G30	Ø16.46 x 0.79	1.968 - 0.002	0.551 x 0.354 x 3.150

* 1.181 for IS6 & IS7.

** 0.315 x 0.276 x 1.575 for IS6 & IS7.

Gearbox	Max Bore ANSI B17.1		Max Acme Thread (inch)	Max Acme Thread (mm)	Weight (lb)
	Square	Rectangle			
IS2	1.5	1.625	1 3/4"	45	42
IS3	1.875	2	2 1/8"	55	44
IS4	1.5	1.625	1 3/4"	45	55
IS5	1.875	2	2 1/8"	55	66
IS6	1.875	2	2 1/8"	55	99
IS7	2.5	2.625	2 3/4"	73	110
IS8	2.5	2.625	2 3/4"	73	165
IS9	2.75	3	3 3/8"	86	181
IS10	2.75	3	3 3/8"	86	238
IS11	3.5	3.75	3 7/8"	100	269
IS12	3.5	3.75	3 7/8"	100	408
IS13	4.5	4.625	5"	127	485
IS14	4.625	5	5 7/8"	150	761
IS15	4.5	4.625	5"	127	595
*IS16	4.625	5	5 7/8"	150	882
*IS17	4.5	4.625	5"	127	1279
*IS18	4.625	5	5 7/8"	150	1653
IS19	6.125	6.5	7 3/8"	190	1786
IS20	7.5	7.75	8 3/4"	225	2161
IS21	7.875	8.375	9 1/4"	235	TBC

*Cast bore 2.4 inch.

Gearbox	Ratio	A	B	C	ØD	E	F	G	ØH	I	J	Input Options	Output Options
IS2	1, 2 & 3:1	3.43	8.70	6.02	4.92	-0.20	2.01	4.45	6.77	0.12	2.5 BSP or NPT	FA10 & FA14	FA10
IS3	1, 2 & 3:1	4.29	9.06	6.02	6.77	0.67	2.01	4.45	6.77	0.16	2.5 BSP or NPT	FA10 & FA14	FA14
IS4	2, 3, 4 & 6:1	3.62	8.70	8.03	4.92	0.16	2.01	4.45	10.31	0.12	2.5 BSP or NPT	FA10 & FA14	FA10
IS5	2, 3, 4 & 6:1	4.53	9.41	8.03	6.89	1.06	2.01	4.45	10.31	0.16	2.5 BSP or NPT	FA10 & FA14	FA14
IS6	2, 3, 4, 6 & 8:1	4.69	9.25	12.00	6.54	0.16	2.01	4.45	12.99	0.16	3.5 BSP or NPT	FA10, FA14 & FA16	FA14
IS7	2, 3, 4, 6 & 8:1	4.79	9.29	12.00	7.87	0.20	2.01	4.45	12.99	0.19	3.5 BSP or NPT	FA10, FA14 & FA16	FA16
IS8	4, 6, 8, 10, 12 & 15:1	7.20	13.50	13.11	8.27	1.50	2.36	6.10	12.99	0.19	4 BSP or NPT	FA10, FA14, FA16 & FA25	FA16
IS9	4, 6, 8, 10, 12 & 15:1	7.44	13.74	13.11	11.81	1.73	2.36	6.10	12.99	0.19	4 BSP or NPT	FA10, FA14, FA16 & FA25	FA25
IS10	4, 6, 8, 10, 12 & 15:1	8.70	14.80	14.02	11.81	1.61	2.36	6.10	16.22	0.19	5 BSP or NPT	FA14, FA16 & FA25	FA25
IS11	4, 6, 8, 10, 12 & 15:1	9.53	15.63	14.02	13.78	2.44	2.36	6.10	16.22	0.19	5 BSP or NPT	FA14, FA16 & FA25	FA30
IS12	8, 10, 12 & 15:1	11.10	17.20	16.02	13.78	2.44	2.36	6.10	16.22	0.19	-	FA14, FA16 & FA25	FA30
IS13	8, 10, 12 & 15:1	11.73	17.83	16.02	16.14	3.07	2.36	6.10	20.47	0.19	-	FA14, FA16 & FA25	FA35
IS14	8, 10, 12 & 15:1	16.14	22.24	16.02	18.74	7.48	2.36	6.10	20.47	0.32	-	FA14, FA16 & FA25	FA40
IS15	10, 12 & 15:1	16.26	22.20	17.87	16.14	2.83	2.36	6.10	20.47	0.19	-	FA14, FA16 & FA25	FA35
IS16	10, 12 & 15:1	20.67	26.61	17.87	18.74	7.24	2.36	6.10	20.47	0.32	-	FA14, FA16 & FA25	FA40
IS17	6, 8, 10, 12, 15 & 24:1	19.02	26.10	24.02	16.14	2.83	3.54	7.28	27.76	0.19	-	FA16, FA25, FA30 & FA35	FA35
IS18	6, 8, 10, 12, 15 & 24:1	23.43	30.51	24.02	18.74	7.24	3.54	7.28	27.76	0.32	-	FA16, FA25, FA30 & FA35	FA40
IS19	6, 8, 10, 12, 15 & 24:1	25.47	32.56	24.02	18.74	9.29	3.54	7.28	27.76	0.32	-	FA16, FA25, FA30 & FA35	FA40
IS20	6, 8, 10, 12, 15 & 24:1	27.95	35.04	24.02	21.85	11.77	3.54	7.28	27.76	0.32	-	FA16, FA25, FA30 & FA35	REQUEST
IS21	6, 8, 10, 12, 15 & 24:1	30.71	37.80	24.02	TBC	14.53	3.54	7.28	27.76	0.32	-	FA16, FA25, FA30 & FA35	REQUEST

All dimensions in inches.

Gearbox Selection Chart

Gearbox	Nominal Ratio						Exact Ratio						Manual Output Torque (ft-lb)	Max Manual Thrust (lb x 1000)	Motorised Output Torque (ft-lb)	Max Motorised Thrust (lb x 1000)	Mechanical Advantage					
	1	2	3	4	6	8	1.25	2.04	3.00	4.10	6.00	8.00					1.125	1.830	2.700	3.690	5.400	7.200
IS2	1	2	3				1.25	2.04	3.00				375	12	300	12	1.125	1.830	2.700			
IS3	1	2	3				1.25	2.04	3.00				375	40	300	40	1.125	1.830	2.700			
IS4	2	3	4	6			2.12	3.00	4.10	6.00			625	12	500	12	1.900	2.700	3.690	5.400		
IS5	2	3	4	6			2.12	3.00	4.10	6.00			625	40	500	40	1.900	2.700	3.690	5.400		
IS6	2	3	4	6	8		2.00	3.00	4.00	6.00	8.00		1250	40	1000	40	1.800	2.700	3.600	5.400	7.200	
IS7	2	3	4	6	8		2.00	3.00	4.00	6.00	8.00		1250	80	1000	60	1.800	2.700	3.600	5.400	7.200	
IS8	4	6	8	10	12	15	4.01	6.10	7.95	10.20	12.26	15.03	1875	80	1500	60	3.600	5.490	7.156	9.180	11.030	13.520
IS9	4	6	8	10	12	15	4.01	6.10	7.95	10.20	12.26	15.03	1875	100	1500	80	3.600	5.490	7.156	9.180	11.030	13.520
IS10	4	6	8	10	12	15	4.04	6.11	7.81	10.17	12.11	14.66	4000	100	3000	80	3.633	5.500	7.025	9.156	10.900	13.194
IS11	4	6	8	10	12	15	4.04	6.11	7.81	10.17	12.11	14.66	4000	150	3000	112.5	3.633	5.500	7.025	9.156	10.900	13.194
IS12	8	10	12	15			8.09	9.99	11.83	15.15			8000	150	6000	112.5	7.280	8.993	10.649	13.632		
IS13	8	10	12	15			8.09	9.99	11.83	15.15			8000	250	6000	187.5	7.280	8.993	10.649	13.632		
IS14	8	10	12	15			8.09	9.99	11.83	15.15			8000	350	6000	296.75	7.280	8.993	10.649	13.632		
IS15	10	12	15				9.86	12.00	15.00				14000	250	12000	187.5	8.870	10.800	13.500			
IS16	10	12	15				9.86	12.00	15.00				14000	350	12000	296.75	8.870	10.800	13.500			
IS17	6						6.11						32000	250	30000	187.5	5.500					
IS17	8	10	12	15	24		8.11	10.00	12.03	15.17	24.09		34000	250	32000	187.5	7.300	9.000	10.820	13.650	21.680	
IS18	6						6.11						32000	350	30000	296.75	5.500					
IS18	8	10	12	15	24		8.11	10.00	12.03	15.17	24.09		34000	350	32000	296.75	7.300	9.000	10.820	13.650	21.680	
IS19	6						6.11						32000	500	30000	375	5.500					
IS19	8	10	12	15	24		8.11	10.00	12.03	15.17	24.09		34000	500	32000	375	7.300	9.000	10.820	13.650	21.680	
IS20	6						6.11						32000	750	30000	500	5.500					
IS20	8	10	12	15	24		8.11	10.00	12.03	15.17	24.09		34000	750	32000	500	7.300	9.000	10.820	13.650	21.680	
IS21	6						6.11						32000	975	30000	650	5.500					
IS21	8	10	12	15	24		8.11	10.00	12.03	15.17	24.09		34000	975	32000	650	7.300	9.000	10.820	13.650	21.680	

For manual torque the static safety factor is 1.5.
For motorised torque the static safety factor is 2.

Dimensions

Type	ØH	K	N
F200	8	2.97	3
F300	12	3.96	3
F400	16	3.96	4
F500	20	3.96	4
F600	24	3.96	4
F700	28	3.96	6
F800	32	3.96	6
F900	36	3.96	6
F1000	40	3.96	6
F1100	44	3.96	6
F1200	48	3.96	8

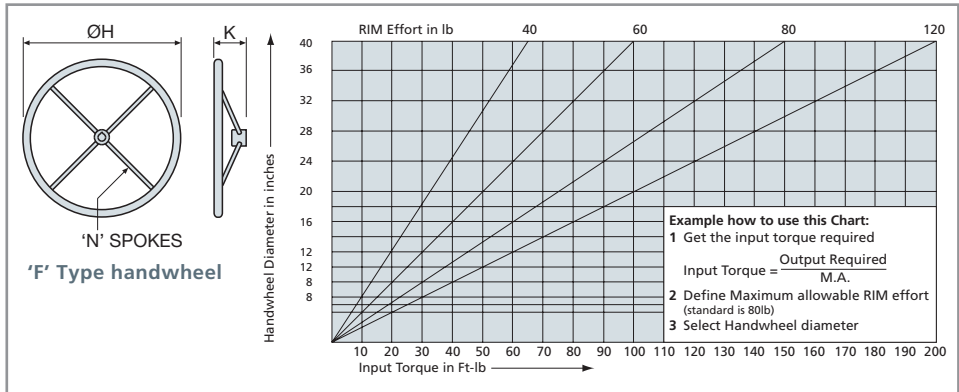

Rotork Gears BV
Nijverheidstraat 25
7581 PV Losser
P.O. Box 98
7580 AB Losser
The Netherlands

tel: +31 (0)53-5388677
fax: +31 (0)53-5383939
email: info@rotorkgears.nl

Rotork Gears UK
Regina House
Ring Road
Bramley, Leeds
West Yorkshire LS13 4ET
England

tel: +44 (0)113 2057276
fax: +44 (0)113 2563556
email: sales@rotorkgears.com

Rotork Gears Americas
1811 Brittmoore
Houston
Texas 77043
USA

tel: +1 713 983 7381
fax: +1 713 856 8022
email: gears@rotorkgears.com

Rotork Gears S.R.L.
via Olona, 65/67
20015 Parabiago (MI)
Italy

tel: +39 0331 552128
fax: +39 0331 553147
email: info@rotorkgears.it

Rotork Gears Shanghai
No. 260 Lian Cao Road
Xin Mei Urban Industrial Park
Min Hang District
Shang Hai 201108
China

tel: 0086-21-64348388
fax: 0086-21-64348366
email: info@rotorkgears.com.cn

A full listing of our worldwide sales and service network is available on our website at

www.rotork.com

Rotork Valvekits
Brookside Way,
Nunn Park,
Huthwaite,
Nottinghamshire, NG17 2NL
England

tel: +44 (0)1623 440211
fax: +44 (0)1623 440214
email: sales@rotorkvalvekits.com

Rotork Gears India
165/166, Bommasandra,
Jigani Link Road,
Kiadb Industrial Area,
Anekal Thaluk, Jigani Hobli,
Bangalore 562106

tel: +91 80 3098 1600
fax: +91 80 3098 1610
email: sales@rotork.co.in

Formerly RGi211E. As part of a process of on-going product development, Rotork reserves the right to amend and change specifications without prior notice. Published data may be subject to change.

For the very latest version release, visit our website at www.rotork.com.

The name Rotork is a registered trademark. Rotork recognizes all registered trademarks. Published and produced in the UK by Rotork Controls Limited. POWTG0411