

600 PSI WWP Bronze Ball Valves

Fire Protection Valve • Two-Piece Body • Chrome Plated Ball •
Blowout-Proof Stem • Reinforced PTFE Seats • Full Port

600 PSI/41.4 Bar Non-Shock Cold Water

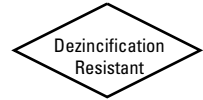

CONFORMS TO MSS SP-110

MATERIAL LIST

PART	SPECIFICATION
1. Handle Nut	Zinc Plated Steel
2. Handle	Zinc Plated Steel Clear Chromate Plastisol Coated
3. Threaded Pack Gland	Brass ASTM B16 Alloy C36000
4. Packing	PTFE
5. Stem	Silicon Bronze ASTM B371 Alloy C69430 or ASTM B99 Alloy C65100
6. Thrust Washer	Reinforced PTFE
7. Ball	Brass ASTM B124 Alloy C37700 or ASTM B16 Alloy C36000 EACH with Hard Chrome Plate
8. Seat Ring (2)	Reinforced PTFE
9. Body	Cast Red Bronze ASTM B584 Alloy C84400
10. Body End Piece	Cast Red Bronze ASTM B584 Alloy C84400

1/4" and 3/8" size only has A304 stainless steel grounding washer.

T-585-70

Threaded

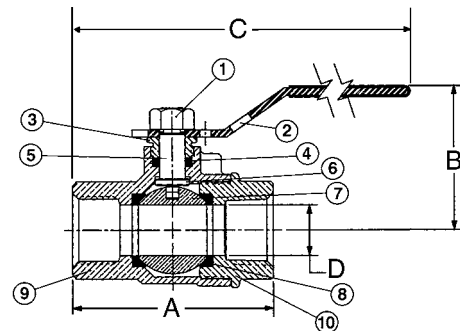

T-585-70

NPT x NPT

DIMENSIONS—WEIGHTS—QUANTITIES

Size	Dimensions								Weight	Box Qty.	Master Ctn. Qty.
	A		B		C		D Port				
In. mm.	In.	mm.	In.	mm.	In.	mm.	In.	mm.	Lbs.	Kg.	
1/4 8	2.00	51	1.75	44	5.00	127	.38	10	.45	.20	10
3/8 10	2.00	51	1.75	44	5.00	127	.38	10	.45	.20	10
1/2 15	2.44	62	1.88	48	5.19	132	.50	13	.64	.29	10
3/4 20	2.94	75	2.25	57	6.25	159	.75	19	1.33	.60	5
1 25	3.34	85	2.38	60	6.44	164	1.00	25	1.79	.81	5
1 1/4 32	4.19	106	3.00	76	6.75	171	1.25	32	2.17	.99	5
1 1/2 40	4.72	120	3.16	80	9.06	230	1.25	32	3.27	1.49	5
2 50	5.16	131	3.50	89	9.25	235	2.00	51	5.09	2.31	2