

Installation and Maintenance Instructions

True Union Ball Check, Foot, and Vent Valves

Installation

Chemtrol union-end check/foot valves can be fitted with socket, threaded, or flanged end connections. When joining union-end valves, or when flanging end connectors, *never make the joint to the end connectors while they are attached to the valve body*. Remove the union nuts and end connectors from the valve cartridge first. In order to prevent mishaps with the union nut, slide it (smallest bore first) over the pipe or nipple-and-flange hub (when flanging) before making the joint to the end connector.

Check valves should be installed at least four feet from the discharge side of a pump. Ball chatter and internal damage may result if fluid flow is too turbulent. Also, in keeping with good mechanical design practice, the upper threshold of fluid flow recommended from Chemtrol products is five feet per second.

Caution: The valves may be installed vertically or horizontally (refer to the preceding page for minimum seating head requirements), but the molded-in flow arrow on the valve cartridge must be installed in the direction of the fluid flow such that reverse flow will be checked. Since the specific gravity of all ball materials is greater than 1.0, the ball check valves cannot be inverted to function as a vent valve by allowing the ball to float into seating position.

Threaded-End—Refer to the plastic thread joining instructions in the Chemtrol Thermoplastic Piping Technical Manual for proper joining techniques. **Caution: Do not overtighten threads. Usually, one to two turns beyond hand-tight using a suitable strap-wrench, if necessary, is sufficient. (ANSI B1.20.1 defines hand tight as 4 to 5 threads for sizes through 2" and 5 to 6 3/4 threads for sizes over 2").**

Socket-End Valves—Refer to the solvent cement joining instructions in the Chemtrol Thermoplastic Piping Technical Manual for proper joining techniques. **Caution: Do not allow purple primer or solvent cement to come in contact with the sealing face of the end connectors or internal components of the valve.**

For PP or PVDF valves, refer to the heat fusion joining instructions in the Chemtrol Thermoplastic Piping Technical Manual for proper joining techniques. **Caution: Chemtrol valves require special heat fusion tools to make proper connections.** These tools can be found in the Chemtrol Fitting Guide.

Flanged-End Valves—Refer to the plastic flange joining instructions in the Chemtrol Thermoplastic Piping Technical Manual for proper joining techniques. **Caution: Do not overtighten flanges.**

Valve Cartridge—After allowing the proper joining curing time, end connections may be joined to the valve cartridge. O-rings provide the seal between the valve faces and the end connector faces. **Ensure that these O-rings are clean and in their proper grooves before slipping the valve cartridge between its end connectors.** Slide the union nuts over the end connectors and screw onto the valve cartridge threads, no more than hand-tight.

Foot Valve Conversion—Foot valve screen housing assemblies are available to convert ball check valves to foot valves in the field. The assemblies, discussed on the preceding page and seen in the split-view drawing on this page, are to be installed on the supply side of a standard Chemtrol Ball Check Valve, replacing the union nut and end connector. Foot valves are normally installed in an open tank or sump on the suction side of a pump. Its function is to screen debris from entering the pump.

Vent Valve Conversion—The ball in a standard Chemtrol Ball Check Valve is intended by design to have a greater density than the fluid medium. When installed in the upright (seat down – arrow on body pointed in direction of normal flow) to horizontal positions, gravitational force on the ball allows it to sink in the fluid and seal at the seat in order to prevent back-flow when directional flow is ceased (e.g., pump stops). However, the mechanical designer sometimes wants air or gas to be vented from a piping system or vessel as fluid fills the system, but to check flow of fluid beyond the vent tube. As fluid is evacuated from the system or vessel, the vent valve must open to prevent formation of a vacuum. *The field conversion of the check valve to the venting*

function requires the replacement of the standard ball with a polypropylene ball, which will float in water or fluids of greater density. See the Components of Valve Construction chart on the preceding page and the drawing on this page. A vent valve must be installed in the inverted vertical position (seat up – arrow on body pointed in opposite direction of normal venting). **Caution: The floater ball must also be chemically resistant to the medium. Good oxidizers may stress crack the polypropylene ball (e.g., bleach, concentrated sulfuric or nitric acids).**

Adjustment—Adjustment to the seating action is not required. However, each of the union nuts must apply adequate force on its end connector to prevent shell leaks at the O-ring face seals on each end of the body. Obviously, further tightening of the union nuts should stop shell leaks at these locations if the O-rings have been properly seated in their grooves. If unable to adjust the nut by hand, a suitable strap-wrench may be used. **Caution: Do not overtighten. Usually, 1/4 turn or less adjustment is sufficient to restore the valve to sealing condition.**

Maintenance

Should a valve need repair, depressurize and drain the system on both sides of the valve. Loosen the valve union nuts and slide them back over the end connections. To minimize downtime, it may be advisable to have a replacement valve cartridge ready to install in place of the one to be repaired. Disassemble valve cartridge as follows:

1. Insert a soft, blunt instrument into the downstream end of the valve and push the ball and seal carrier out of the upstream end of the valve.
2. Examine all parts and replace any damaged or worn components with new replacement parts. If the body is damaged, we recommend replacing the entire valve cartridge.

A Replacement Parts List for Chemtrol union-end type ball check and foot valves may be found on page 13. The valve should be properly identified before selecting replacement parts. **Caution: Valve repair should only be performed by qualified maintenance personnel. Contact your nearest Chemtrol distributor should further information be required.**

Valve Seat—The fluid seal between the ball and body seat (chamfered shoulder) is affected by a standard O-ring located in a groove in the body seat. This seat seal is included in the O-ring kit, which is identified in the Replacement Parts List.

Notes

See page 13 for a list of *Components and Construction Materials*. For more insight into the selection of materials, refer to *Materials*, page 1. For the specific relationship of pressure vs. temperature, refer to *Engineering Data*, page 28. For *Chemtrol Valve Standards*, see page 29.

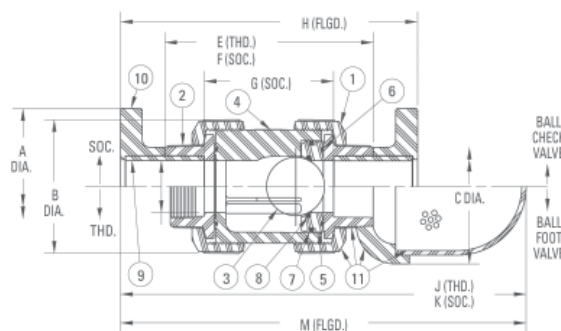

To determine suitability of Chemtrol Valves in your application, consult the Chemtrol Chemical Resistance Guide.

Chemtrol Figure Numbers

| Type Valve | End Conn | Elast-omeric Trim | Materials | | | | | |
|------------------|----------|-------------------|--|--|---------------|---------------------------|---------------|---------------|
| | | | PVC | CPVC | Black Polypro | Chem-Pure Natural Polypro | Red PVDF | Natural PVDF |
| Ball Check Valve | Soc. | FKM EPDM | U45BC-V ¹ U45BC-E ¹ | U51BC-V ¹ U51BC-E ¹ | S61BC-V NA | S62BC-V NA | S65BC-V NA | S66BC-V NA |
| | Thd. | FKM EPDM | U45BC-V ¹ U45BC-E ¹ | U51BC-V ¹ U51BC-E ¹ | T61BC-V NA | NA NA | T65BC-V NA | T66BC-V NA |
| | Flgd. | FKM EPDM | F45BC-V F45BC-E | F51BC-V F51BC-E | F61BC-V NA | NA NA | F65BC-V NA | F66BC-V NA |

1 1/2"–2" PVC and CPVC TU ball check figures are supplied with universal connection components (i.e., a set of both socket and threaded end connectors). For 3" and 4" sizes of PVC and CPVC BC valves, replace U in the figure no. with S or T for socket or threaded units respectively. All sizes of PP and PVDF TUBC valves require stipulation of end connectors in their figure no.