

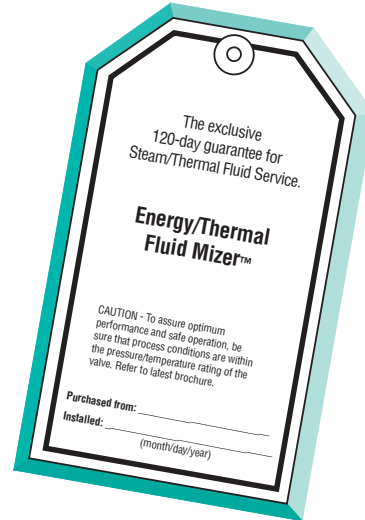

FCD WCABR1043-01  
(Part SV 601)

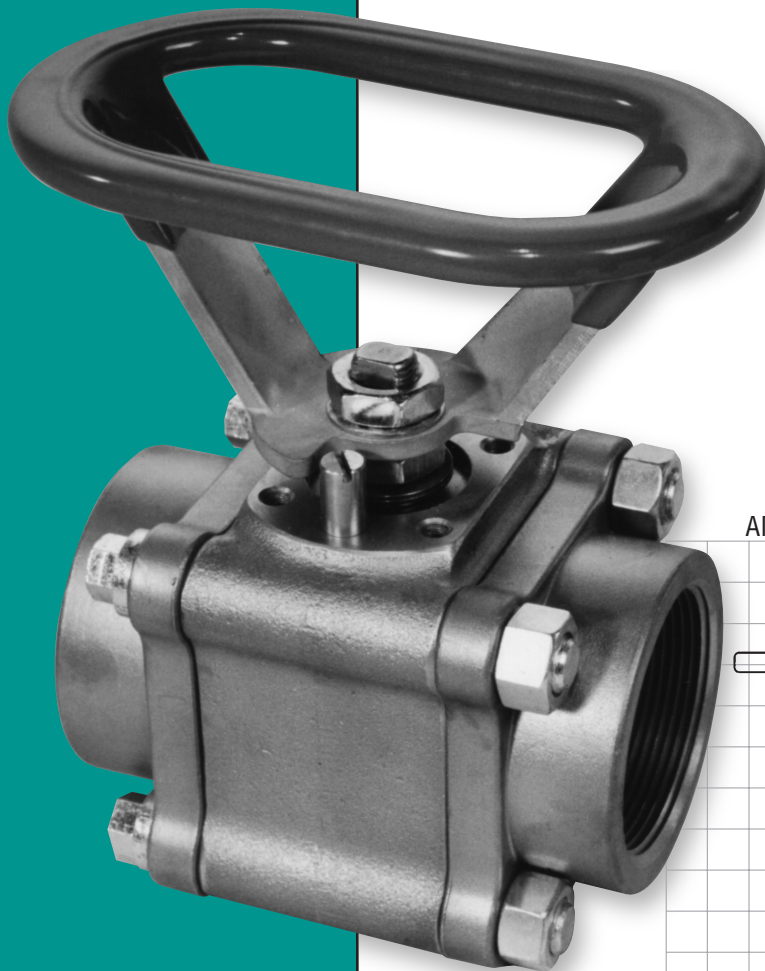

AN ISO 9001 REGISTERED COMPANY

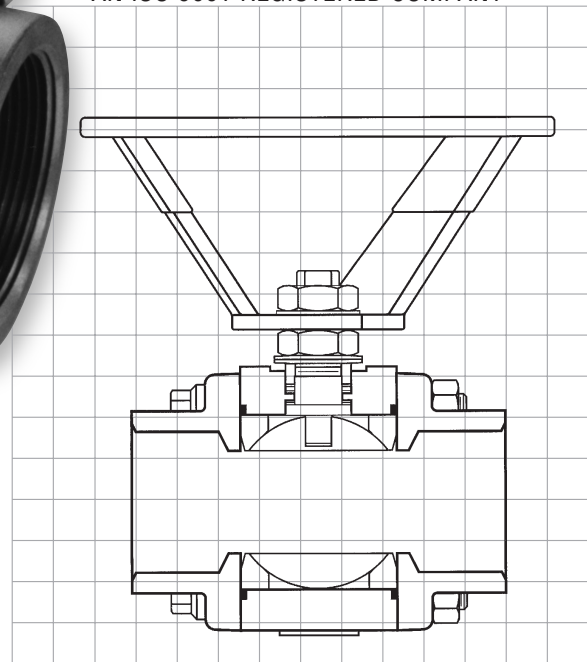

# *Worcester Controls Energy/Thermal Fluid Mizer*

*Rugged ball valve for steam and thermal fluid service*

## Features and Benefits



**1/4" - 2" W44  
Three-Piece Valves**  
**1/4" - 1 1/2" W59  
Full Port  
Three-Piece Valves**



**1/2" - 6" W52  
Flanged Valves**



**Optional V-48  
Extended  
Lever Handle**



**Series 32  
Gear Operator**



**Series W44 V1/V2  
Diverter  
Ball Valves**

**Note:** Standard Flowserve Worcestor valves are assembled with silicone-based break-in lubricant. For other options, consult your distributor or Flowserve.

- Provides positive shutoff and leaktight integrity for steam service to 500# WSP or thermal fluid services to 650°F.
- Low torque, quarter turn operation for ease of automation.
- Live loaded stem seals minimize maintenance and assure years of trouble-free service.
- Optional extended handles and OSHA lockout capabilities provide maximum personnel safety.
- ASME B16.34 pressure vessel design for maximum structural integrity.
- Multiple body style option for all piping requirements: three-piece, flanged, wafer, full port or diverter.
- Optional vented (V3) ball to reduce damage caused by trapped cavity pressure.
- Optional "clean room" and silicon free assembly available for high purity steam applications.

## Flow Coefficient - W44 & W59

| Valve Size  | W44 Cv | Equiv. Length of Schedule 40 pipe (ft.) | W59 Cv | Equiv. Length of Schedule 40 pipe (ft.) |
|-------------|--------|---|--------|---|
| 1/4" - 3/8" | 8      | 0.9                                     | 8      | 0.9                                     |
| 1/2"        | 8      | 3.1                                     | 38     | 1.4                                     |
| 3/4"        | 12     | 6.3                                     | 71     | 1.0                                     |
| 1"          | 32     | 3.1                                     | 110    | 1.2                                     |
| 1 1/4"      | 46     | 6.3                                     | 230    | 2.1                                     |
| 1 1/2"      | 82     | 4.3                                     | 350    | 2.1                                     |
| 2"          | 120    | 7.5                                     | 600    | 2.1                                     |

**Note:** For Flow Coefficients, dimensions and further technical information on other Energy/Thermal Fluid Mizer styles and sizes, refer to the following Worcestor brochures: Large 3-piece, SB 45; Large full port 3-piece, WCABR1011; Flanged, SB 51; Wafer, WCABR1041; Diverter, WCABR1017.

## Steam Ratings

| Valve Size                          | Polyfill®              |                           | High-per Fill®         |                           |
|-------------------------------------|------------------------|---------------------------|------------------------|---------------------------|
|                                     | Working Steam Pressure | Corresponding Temperature | Working Steam Pressure | Corresponding Temperature |
| 1/4", 3/8", 1/2"<br>(1/4"-3/8" W59) | 450                    | 459°F                     | 500                    | 470°F                     |
| 3/4"<br>(1/2" W59)                  | 425                    | 455°F                     | 500                    | 470°F                     |
| 1"<br>(3/4" W59)                    | 400                    | 447°F                     | 500                    | 470°F                     |
| 1 1/4"<br>(1" W59)                  | 350                    | 435°F                     | 500                    | 470°F                     |
| 1 1/2"<br>(1 1/4" W59)              | 325                    | 428°F                     | 500                    | 470°F                     |
| 2"<br>(1 1/2" W59)                  | 300                    | 424°F                     | 500                    | 470°F                     |
| 2 1/2" - 6"<br>(2" - 4" W59)        | 250                    | 406°F                     | 300                    | 424°F                     |

## Thermal Fluid Ratings

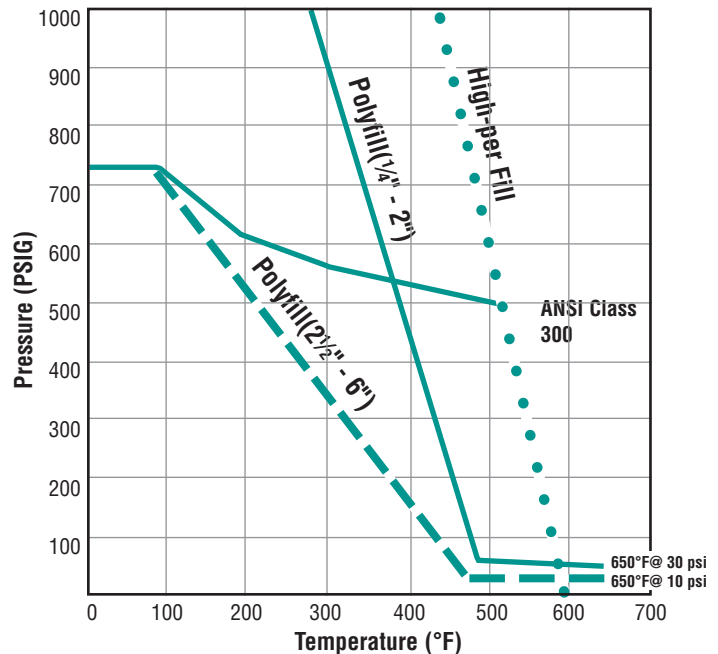

## Specifications

- Sizes:** 1/4"-6"  
**Styles:** 3-Piece, 3-Piece Full Port, Flanged, Wafer, Diverter  
**Connections:** Screwed, Socket Weld, Butt Weld, Class 300 ANSI Flanged, Class 300 ANSI Wafer  
**Standards:** SE valves meet ANSI B2.1  
 BW valves meet ANSI B16.25  
 Flanged valves meet ANSI B16.5, B16.10 and B16.34\*  
 SW valves socket dimensions meet ANSI B16.11  
**Leakage Rate:** Bubbletight  
 \*Hydro test by customer request - V5 option

### PRESSURE RATINGS - Steam

The steam rating table shows maximum valve pressure ratings. Energy/Thermal Fluid Mizer Valves may be used on superheated steam provided the service temperature does not exceed the temperatures shown.

### PRESSURE RATINGS - Thermal Fluids

|                    |           |          |
|--------------------|-----------|----------|
| W44 & W44 Diverter | 1/4"-2"   | 1000 psi |
| W59                | 1/4"-2"   | 1000 psi |
|                    | 3"-4"     | 720 psi  |
| W52                | 1/2"-6"   | 720 psi  |
| W45                | 2 1/2"-6" | 720 psi  |
| W4 301             | 3"-6"     | 720 psi  |

Refer also to Pressure/Temperature limit curves.

## Automation

Flowserve Worcester Controls offers a complete line of pneumatic and electric automation packages for Series Energy/Thermal Fluid Mizer valves. Both electric and pneumatic packages are offered for on/off operation. Available options include:

### FOR ELECTRIC CONTROL

- Type 4x, 7 & 9 enclosures
- Remote position indication
- Computer interface
- Digital compatible
- Ask for Brochure WCABR1014



- Type 4, 4x, 7, 9 and 12 enclosures
- Failsafe operation
- Maintenance free hydraulic system
- Ask for Brochure WCABR1022



### FOR PNEUMATIC CONTROL

- Failsafe operation
- End & top mounted limit switches
- Proximity switches
- Digital compatible
- Ask for Brochure WCABR1003



## Dimensions inches (mm)

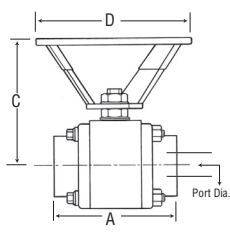

Standard Stainless Steel Oval Handle

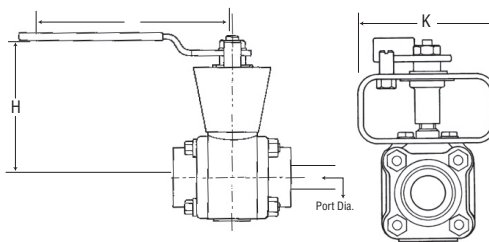
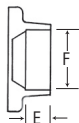
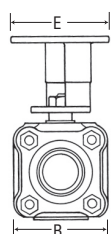

Optional V48 Extended Lever Handle

| Valve Size |           | A              | B              | C              | D             | E              | F              | G              | H             | J             | K             | Port           | Approx. Weight lbs.(kg.) |
|------------|-----------|----------------|----------------|----------------|---------------|----------------|----------------|----------------|---------------|---------------|---------------|----------------|--------------------------|
| W44        | W59       |                |                |                |               |                |                |                |               |               |               |                |                          |
| 1/4"       | —         | 2.54<br>(64.5) | 1.75<br>(44.5) | 3.76<br>(95.5) | 4.56<br>(116) | 3.06<br>(77.7) | .555<br>(14.1) | .440<br>(11.2) | 4.09<br>(104) | 6.53<br>(166) | 4.00<br>(102) | 0.44<br>(11.2) | 1.20<br>(.55)            |
| 3/8"       | —         | 2.54<br>(64.5) | 1.75<br>(44.5) | 3.76<br>(95.5) | 4.56<br>(116) | 3.06<br>(77.7) | .690<br>(17.5) | .440<br>(11.2) | 4.09<br>(104) | 6.53<br>(166) | 4.00<br>(102) | 0.44<br>(11.2) | 1.20<br>(.55)            |
| 1/2"       | 1/4"-3/8" | 2.54<br>(64.5) | 1.75<br>(44.5) | 3.76<br>(95.5) | 4.56<br>(116) | 3.06<br>(77.7) | .855<br>(21.7) | .440<br>(11.2) | 4.09<br>(104) | 6.53<br>(166) | 4.00<br>(102) | 0.44<br>(11.2) | 1.20<br>(.55)            |
| 3/4"       | 1/2"      | 2.76<br>(70.1) | 2.00<br>(50.8) | 3.86<br>(98.0) | 4.56<br>(116) | 3.06<br>(77.7) | 1.07<br>(27.1) | .560<br>(14.2) | 4.20<br>(107) | 6.53<br>(166) | 4.00<br>(102) | 0.56<br>(14.2) | 1.9<br>(.86)             |
| 1"         | 3/4"      | 3.66<br>(93.0) | 2.38<br>(60.5) | 4.29<br>(109)  | 4.56<br>(116) | 3.06<br>(77.7) | 1.33<br>(33.8) | .720<br>(18.3) | 4.32<br>(110) | 6.53<br>(166) | 4.00<br>(102) | 0.81<br>(20.6) | 3.2<br>(1.45)            |
| 1 1/4"     | 1"        | 4.16<br>(106)  | 2.70<br>(68.6) | 4.50<br>(114)  | 6.06<br>(154) | 3.56<br>(90.4) | 1.68<br>(42.5) | .720<br>(18.3) | 4.51<br>(115) | 6.53<br>(166) | 4.00<br>(102) | 1.00<br>(25.4) | 4.6<br>(2.08)            |
| 1 1/2"     | 1 1/4"    | 4.50<br>(114)  | 3.16<br>(80.3) | 4.83<br>(123)  | 6.06<br>(154) | 3.56<br>(90.4) | 1.92<br>(48.6) | .720<br>(18.3) | 5.37<br>(136) | 8.03<br>(204) | 5.00<br>(127) | 1.25<br>(31.8) | 6.3<br>(2.87)            |
| 2"         | 1 1/2"    | 4.94<br>(126)  | 3.56<br>(90.4) | 5.03<br>(128)  | 6.06<br>(154) | 3.56<br>(90.4) | 2.41<br>(61.1) | .840<br>(21.3) | 5.55<br>(141) | 8.03<br>(204) | 5.00<br>(127) | 1.50<br>(38.1) | 9.6<br>(4.36)            |

Dimensions are given for layout purposes only. For tolerances, consult your Worcester Controls distributor. Metric equivalents are converted from Standard English. For 2" and larger full port valve dimensions, consult Flowserve.

## How to Order

| Size          | Operations   | Series                            | Body Mtl.  | Ball & Stem         | Seat                              | Seal   | End Connection   | Variations                              |
|---------------|--|-----------------------------------|--|---------------------|-----------------------------------|--|--|---|
| 3"            |  |                                   |  |                     |                                   |  |  |   |
| W52           |  |                                   |  |                     |                                   |  |  |   |
| 4             |  |                                   |  |                     |                                   |  |  |   |
| 6             |  |                                   |  |                     |                                   |  |  |   |
| P             |  |                                   |  |                     |                                   |  |  |   |
| Z             |  |                                   |  |                     |                                   |  |  |   |
| 300           |  |                                   |  |                     |                                   |  |  |   |
| **            |  |                                   |  |                     |                                   |  |  |   |
| 1/4" - 2"     | Blank - Built with handle oval                         | W44 - 3-piece                     | 4 - Carbon Steel<br>6 - Stainless Steel                                  | 6 - Stainless Steel | P - Polyfill<br>X - High-per Fill | M - TFE coated 316 S.S.  | SE - Screw End<br>SW - Socket Weld   | V-Numbered options - See listing below. |
| 1/2" - 2"     |  | W44 - diverter*                   |  |                     |                                   | M - TFE coated 316 S.S.  | SE - Screw End<br>SW - Socket Weld   | Leave blank if no variations.           |
| 2 1/2" - 6"   | E - No handle valve built for automation               | W45 - large* three-piece          |  |                     |                                   | G - Graphite Coated 316 S.S. (2 1/2"-4" only)<br>T - TFE (6" only)           | SE - Screw End<br>SW - Socket Weld<br>BW4 - Butt Weld sch. 40 carbon steel |   |
| 1/4" - 1 1/2" | B - No handle for automation using 39 or 75 actuators. | W59 - Fullport three-piece        |  |                     |                                   | M - TFE coated 316 S.S.  | SE - Screw End<br>SW - Socket Weld   |   |
| 2" - 4"       | (1/4" - 2" W44, 1/4" - 1 1/2" W59, 1/2" - 2" W52)      | W59 - large* Fullport three-piece |  |                     |                                   | Z - (2" only)<br>G - Graphite coated 316 S.S. (3" only)<br>T - TFE (4" only) | SE - Screw End<br>SW - Socket Weld<br>BW4 - Butt Weld sch. 40 carbon steel |   |
| 1/2" - 2"     |  | W52 - Flanged                     |  |                     |                                   | M - TFE coated 316 S.S.  | 300 - ANSI 300   |   |
| 3" - 6"       |  | W52 - large Flanged               |  |                     |                                   | Z - Graphite   | 300 - ANSI 300   |   |
| 3" - 6"       |  | W4 - Wafer                        | 1 - Brass<br>2 - Ductile Iron<br>4 - Carbon Steel<br>6 - Stainless Steel |                     |                                   | Z - Graphite   | 301 - Wafer ANSI 300   |   |

\* W45, 2"-4" W59 and W44 diverter valves available in carbon steel only. For V1 or V2 port configuration, refer to Brochure WCABR1017.

**ORDERING EXAMPLE:** 3" Flanged Energy/Thermal Fluid Mizer Ball Valve with Carbon steel body, stainless steel ball and stem, Polyfill seats, Graphite Seals and ANSI 300 Flanges.

**NOTE:** Worcester Ball valves will give superior service in "ON/OFF" steam applications. For throttling service, consider the Worcester characterized seat control valve. Ask for Brochure WCABR1001. For some thermal cycling applications where condensate may become trapped in the ball, the V-3 Upstream Relief Hole is recommended. Consult Flowserve.

### \*\*Variations (V-numbers)

- |   |  |
|---|--|
| V1 - 90° Porting                            | V36 - Certificate of Compliance  |
| V2 - 180° Porting (Diverter only)           | V37 - Certificat of Compliance & Hydro Testing   |
| V3 - Upstream Relief Hole                   | V46 - Silicon Free Lubricant   |
| V6 - Source Inspection                      | V48 - Extended Lever Handle (1/4" - 2" W44 & Diverter, 1/4" - 1 1/2" W59, 1/2" - 2" W52) |
| V14 - Handleless Valve (3"-6" sizes only)   | V51 - High Cycle Stem Build (3" - 6" sizes only)   |
| V17 - Grounding Thrustbearing               | V58 - B16.34 Compliance  |
| V20 - Oxygen Service                        | V59 - Extended Oval Handle (1/4" - 2" W44 & Diverter, 1/4" - 1 1/2" W59, 1/2" - 2" W52)  |
| V32 - Oval Handle (1/2" - 2" W52 only)      | V60 - OSHA Lockout (1/4" - 2" W44 & Diverter, 1/4" - 1 1/2" W59, 1/2" - 2" W52)          |
| V33 - Oxygen Service without Source Inspect | V66 - Certificate of Compliance, European Valve Orders                                   |

**CAUTION: Ball Valves can retain pressurized media in the body cavity when closed. Use care when disassembling. Always open valve to relieve pressure prior to disassembly. Due to continuous development of our product range, we reserve the right to alter the product information and specifications contained in this brochure, as required.**

Polyfill®, High-per Fill® and Energy/Thermal Fluid Mizer™ are registered trademarks of Flowserve Corporation.

Flowserve Corporation has established industry leadership in the design and manufacture of its products. When properly selected, this Flowserve product is designed to perform its intended function safely during its useful life. However, the purchaser or user of Flowserve products should be aware that Flowserve products might be used in numerous applications under a wide variety of industrial service conditions. Although Flowserve can (and often does) provide general guidelines, it cannot provide specific data and warnings for all possible applications. The purchaser/user must therefore assume the ultimate responsibility for the proper sizing and selection, installation, operation, and maintenance of Flowserve products. The purchaser/user should read and understand the Installation Operation Maintenance (IOM) instructions included with the product, and train its employees and contractors in the safe use of Flowserve products in connection with the specific application.

While the information and specifications contained in this literature are believed to be accurate, they are supplied for informative purposes only and should not be considered certified or as a guarantee of satisfactory results by reliance thereon. Nothing contained herein is to be construed as a warranty or guarantee, express or implied, regarding any matter with respect to this product. Because Flowserve is continually improving and upgrading its product design, the specifications, dimensions and information contained herein are subject to change without notice. Should any question arise concerning these provisions, the purchaser/user should contact Flowserve Corporation at any one of its worldwide operations or offices.

For more information about Flowserve Corporation, visit [www.flowserve.com](http://www.flowserve.com) or call USA 1 800 225 6989.

**FLOWSERVE FLOW CONTROL**  
 1978 Foreman Drive  
 Cookeville, Tennessee 38501 USA  
 Phone: 931 432 4021  
 Facsimile: 931 432 5518