

Indicator Posts

Fire Protection • Wall Post • For use with non-rising stem indicator post style gate valves

UL/ULC LISTED • FM APPROVED

MATERIAL LIST

PART	SPECIFICATION
1. Cover	Cast Iron ASTM A126 Class B
2. Retaining Ring	Steel #5100-225
3. Operating Nut	Bronze
4. Nut	Steel
5. Screw	Steel ASTM A304
6. Screw	Steel ASTM A304
7. Body	Cast Iron ASTM A126 Class B
8. Target Carrier Nut	Bronze
9. Window - Plate	Plastic
10. Ferrule	Steel
11. Screws - Self Tap	
12. Pipe Plug	Iron
13A. "Open" Target	Cast Aluminum
13B. "Shut" Target	Cast Aluminum
14. Target Retaining Clamp	Plated Steel
15. Nut	Steel
16. Machine Screw	Brass
17. Operator Rod	Steel
18. Cotter Pin	Brass
19. Operator Rod Coupling	Cast Iron
20. Eye Bolt	Steel
21. Nut	Steel
22. Washer	Plated Steel
23. Handwheel	Cast Iron

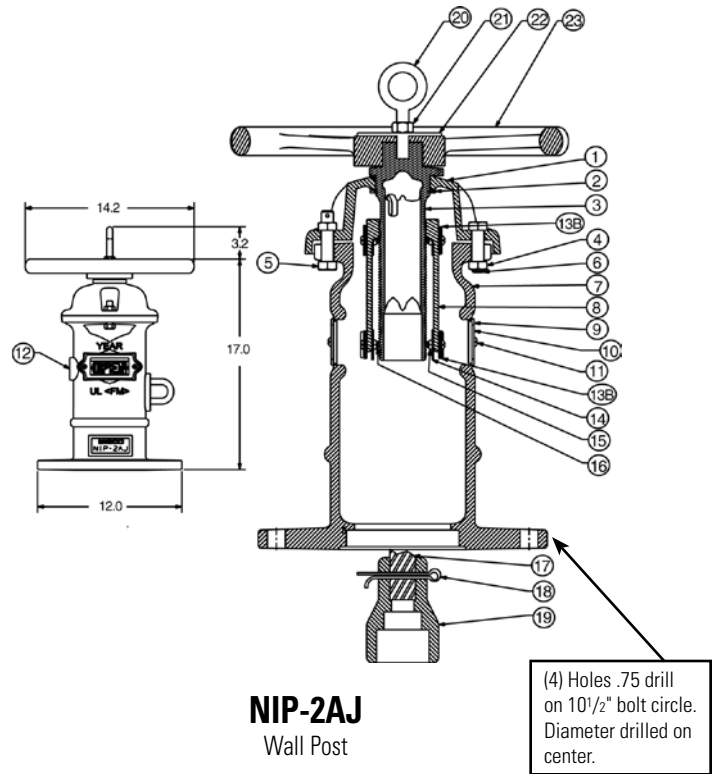

NIP-2AJ
Wall Post

Weight includes stem rod and coupling

	Lbs.	Kg.
NIP-1AJ - Upright Adjustable Post	150	68
NIP-2AJ - Wall Post	80	36

Note: 63" long 1" square rod supplied with NIP-1AJ and NIP-2AJ

Indicator Post Gate Valve Dimensions

Valve Size	4"		6"		8"		10"		12"		
	In.	mm.	In.	mm.	In.	mm.	In.	mm.	In.	mm.	
Dimension from centerline of valve to top of the operating nut	F/M609 (IBBM)	14.1	358	18.6	472	22.1	561	25.8	655	29.5	749
	F/M609RW	13.5	342	17.0	432	20.5	520	23.8	605	27.0	686
Turns to open (±.5 turn)	F/M609 (IBBM)	9		13.5		17.5		30.25		38.25	
	F/M609RW	12.8		15		17.6		21.2		25.1	

