

CPVC/PVC Butterfly Valves—Model-B

4" & 6" Body, Disk/Stem and Throttle Plate are PVC. 3" components are CPVC.

150 psi at 73°F water—non-shock (6" size 115 psi)



The Model-B is the best butterfly valve for chemical applications. The disk and stem sheath are molded over a 316 stainless hex shaft to make a one-piece assembly, making it impossible for the metal shaft to be exposed to the fluid medium over its full length of top and bottom stem. The upper and lower PTFE bearing-bushings are vulcanized to the seat/boot as the boot is molded, making leakage between the boot and bushings impossible. The grooves for double O-ring seals are machined in the stem sheath of protective plastic for redundant stem leakage protection in conjunction with both the upper and lower bushings. Since these back-up stem seals rotate against the PTFE bushings, valve shell leakage, indicating wear on the outside of these seals, is virtually unreported.

Features

- Mates between ANSI B 16.5, Class 150; ISO 2084 PN 10, DN 80; and DIN 2532, PN 10, DN 80. Both 4-bolt and 8-bolt patterns are in 3" size.
- Unique "dry shaft seal" – liquid never contacts shaft.
- Top bearing, as well as the upper and lower bushings, are glass-filled PTFE for ease of operation and maximum service life.
- Seat/boot design eliminates need for gaskets between mating flanges.
- Selection of FKM or EPDM seat and seals offers resistance to diverse chemical/water applications. With FKM trim, valves have been notably successful in the disinfection services of chlorine and bleach injection.
- Refer to the *Chemtrol Valve Actuation Guide* for a full selection of electrical and pneumatic actuators with accessories. Mounting kits are available for field or factory assembly.

Notes

Installation and Maintenance Instructions for these valves appear on page 12. For more insight into the selection of materials, refer to *Materials*, page 1. *Actuation Mounting Data* for butterfly valves may be found on page 21, followed by a complete listing of *Valve Accessories*. For the specific relationships of pressure vs. temperature ratings, refer to *Engineering Data*, page 28. For *Chemtrol Valve Standards*, see page 29.

C_v Table

| Size | Degrees Open | | | | | | | | |
|------|--------------|-----|-----|-----|-----|-----|-----|------|------|
| | 10° | 20° | 30° | 40° | 50° | 60° | 70° | 80° | 90° |
| 3 | 4.3 | 16 | 35 | 62 | 94 | 135 | 180 | 235 | 290 |
| 4 | 8.6 | 34 | 76 | 137 | 215 | 310 | 420 | 550 | 690 |
| 6 | 17.5 | 67 | 200 | 265 | 410 | 580 | 790 | 1040 | 1340 |

Model-B Butterfly Valve Dimensions—Weights

| Valve Size | A | B | C | D | E | J | G | H | R | Handle | | | Approx. ¹ Wt./Lbs. |
|------------|------|------|-------|------|-------|------|------|------|-----|--------|------|------|----------------------------------|
| | | | | | | | | | | S | T | U | |
| 3 | 4.75 | 1.26 | 7.00 | 3.06 | 8.50 | 2.00 | 3.62 | 3.38 | .44 | 10.50 | 1.81 | 4.22 | 3.25 |
| 4 | 6.13 | 1.22 | 9.00 | 4.00 | 10.63 | 2.22 | 3.62 | 3.38 | .56 | 10.50 | 1.81 | 4.22 | 6.00 |
| 6 | 7.50 | 1.62 | 11.00 | 5.97 | 13.00 | 2.77 | 3.76 | 3.50 | .88 | 15.00 | 2.34 | 5.70 | 12.00 |

¹ Operator not included in weight.

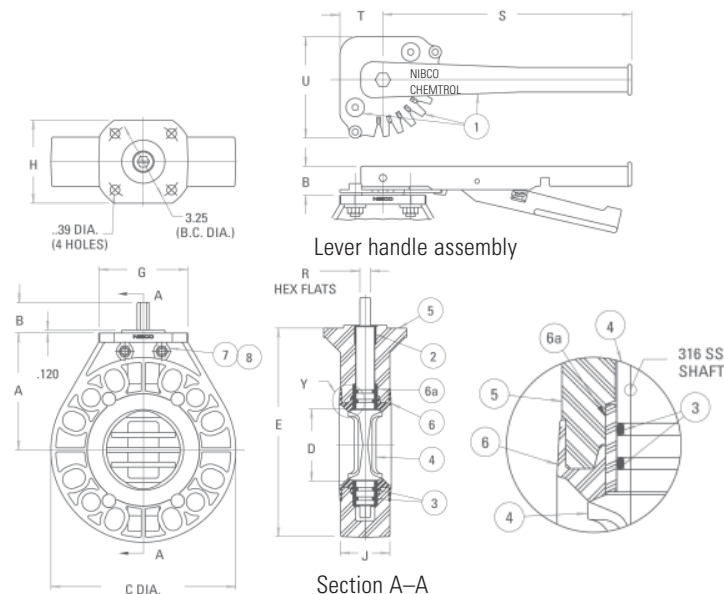

Chemtrol Figure Numbers

| Seat Material | Operating Mechanism | 3" (CPVC) ³ Figure No. | 4" (PVC) Figure No. | 6" (PVC) Figure No. |
|------------------|--------------------------------|--------------------------------------|------------------------|------------------------|
| EPDM | No Operator | W51BF-E-NO | W45BF-E-NO | W45BF-E-NO |
| | With Lever ² Handle | W51BF-E-LH | W45BF-E-LH | W45BF-E-LH |
| FKM ¹ | No Operator | W51BF-V-NO | W45BF-V-NO | W45BF-V-NO |
| | With Lever ² Handle | W51BF-V-LH | W45BF-V-LH | W45BF-V-LH |
| | With Gear Operator | NA | W45BF-E-GO | W45BF-E-GO |
| | With Gear Operator | NA | W45BF-V-GO | W45BF-V-GO |

- 1 Fluoropolymer elastomer is also known as FKM.
2 Includes throttle plate and hardware.
3 Body and disk/stem for 3" size are available in CPVC only.

Construction

| Part | Material |
|-------------------------------------|--|
| 1. Lever Handle Assembly | Cast Iron w/ PVC ¹ Index Throttle Plate |
| 2. Top Bearing | Glass-Filled PTFE |
| 3. O-Ring Seal (4 required) | FKM ² or EPDM |
| 4. Disk/Stem | PVC ¹ w/ 316 Stainless Hex Shaft Insert-Molded |
| 5. Body (2 required – mirror image) | 3" - CPVC ¹ ; 4" & 6" - PVC |
| 6. Seat/Boot | FKM ² or EPDM w/ GF-PTFE Upper & Lower Bearing-Bushings Insert-Molded |
| 7. Cap Screws; | 3" Valve (6) ea. 1/4"-20 x 7/8" Long Zinc Coated |
| | 4" Valve (6) ea. 5/16"-18 x 1" Long Zinc Coated |
| | 6" Valve (6) ea. 5/16"-18 x 1-1/2" Long & (2) ea. 5/16"-18 x 1" Long Zinc Coated |
| 8. Hex Nuts; | 3" Valve (6) ea. 1/4"-20 Zinc Coated |
| | 4" Valve (6) ea. 5/16"-18 Zinc Coated |
| | 6" Valve (8) ea. 5/16"-18 Zinc Coated |

- 1 Body, disk/stem, and throttle plate for 3" size are available in CPVC only.
2 Fluoropolymer elastomer is also known as FKM.