

175 PSI WWP Bronze Hose Gate Valves

Fire Protection Valve • Screw-in Bonnet • Non-Rising Stem • Solid Wedge

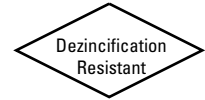

175 PSI/12.1 Bar Non-Shock Cold Water

CONFORMS TO MSS SP-80 •
UL LISTED* • FM APPROVED

MATERIAL LIST

PART	SPECIFICATION
1. Handwheel Nut	Brass ASTM B16
2. Handwheel	Malleable Iron
3. Stem	Silicon Bronze ASTM B371 Alloy C69430
4. Packing Nut	Bronze ASTM B62
5. Packing Gland	Brass ASTM B16
6. Packing	Non Asbestos Aramid Fibers w/Graphite
7. Stuffing Box	Bronze ASTM B62
8. Bonnet	Bronze ASTM B62
9. Body	Bronze ASTM B62
10. Wedge	Bronze ASTM B62
11. Hose Cap	Bronze ASTM B62
12. Hose Cap Gasket	Rubber
13. Safety Chain	Brass



T-103-HC

Threaded
w/Cap and Chain

* Compliance with the Standard for Hose Valves for Fire Protection Service, UL 668.

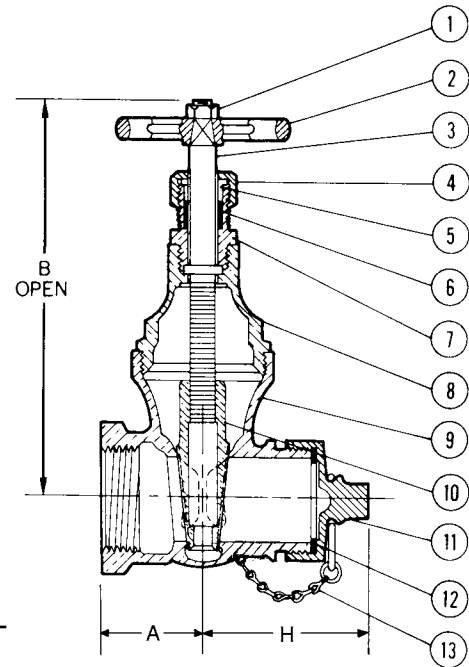

T-103-HC
NPT x ANFH (NFPA)
Hose 7.5 Threads
Per Inch

DIMENSIONS—WEIGHTS—QUANTITIES

Size	Dimensions						Weight		Box Qty.	Master Ctn. Qty.
	A		B		H		Lbs.	Kg.		
In. mm.	In.	mm.	In.	mm.	In.	mm.				
2½ 65	3.00	80	11.38	288	4.75	121	18.52	8.39	1	2

