

175 PSI WWP Bronze Globe Valves

Fire Protection Valve • Threaded Ends • Rubber Disc • Screw Over Bonnet

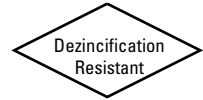

175 PSI/12.1 Bar Non-Shock Cold Water

UL LISTED*

MATERIAL LIST

PART	SPECIFICATION
1. Handwheel	Aluminum
2. Handwheel Screw	Carbon Steel Stainless Steel (1")
3. Stem	Bronze ASTM B584 Alloy C84400 or ASTM B505 Alloy C84400
4. Packing Nut	Bronze ASTM B584 Alloy C83600 or ASTM B16
5. Packing	Graphite Impregnated (Non Asbestos)
6. Bonnet	Bronze ASTM B584 Alloy C84400
7. Body	Bronze ASTM B584 Alloy C84400
8. Seat Disc	EPDM Rubber (1/4" - 3/8") Nitrile (1/2" - 1")
9. Seat Screw	Stainless Steel
10. Pack Washer	Sheet Brass



KT-65-UL
Threaded

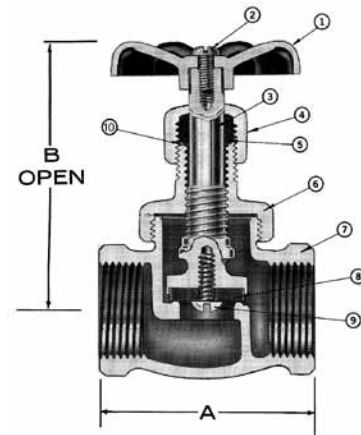

KT-65-UL
NPT x NPT

DIMENSIONS—WEIGHTS—QUANTITIES

Size	Dimensions				Weight		Box Qty.	Master Ctn. Qty.
	A		B		Lbs.	Kg.		
In. mm.	In.	mm.	In.	mm.				
1/4 8	2.00	50	2.75	70	.48	.22	10	100
3/8 10	2.00	50	2.75	70	.45	.20	10	100
1/2 15	2.28	58	3.12	79	.68	.31	10	60
3/4 20	2.28	58	3.12	79	.74	.34	10	60
1 25	3.12	79	4.50	114	1.68	.76	5	25

* UL Listed for Trim and Drain use (Subject 258) – sizes 1/2", 3/4", 1".

Size 1/4" and 3/8" supplied as KT-65 (Not UL Listed).

