

300 PSI WWP Bronze Hose Angle Valves

Fire Protection Valve • Rising Stem • Renewable Disc • Screw-in Bonnet

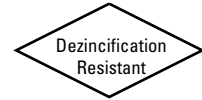

300 PSI/20.7 Bar Non-Shock Cold Water

CONFORMS TO MSS SP-80 •
UL LISTED* • FM APPROVED

MATERIAL LIST

PART	SPECIFICATION
1. Handwheel Nut	Brass ASTM B16
2. Handwheel	Malleable Iron
3. Stem	Silicon Bronze ASTM B371 Alloy C69430
4. Packing Nut	Bronze ASTM B62
5. Packing Gland	Bronze ASTM B16 or ASTM B62
6. Packing	Non Asbestos Aramid Fibers w/Graphite
7. Bonnet	Bronze ASTM B62
8. Body	Bronze ASTM B62
9. Disc Holder Nut	Bronze ASTM B62
10. Drive Screw	18-8SS or Silicon Bronze ASTM B 411 Alloy C64700
11. Disc Holder	Bronze ASTM B62
12. Hose Cap	Bronze ASTM B62
13. Seat Disc	Rubber
14. Hose Cap Gasket	Rubber
15. Safety Chain	Brass
16. Seat Disc Nut	Bronze ASTM B62
17. Cotter Key	Brass



T-331-HC
Threaded
w/Cap and Chain

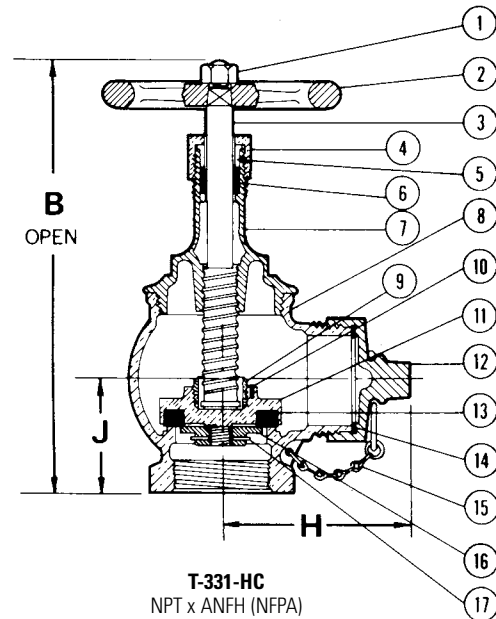

T-331-HC
NPT x ANFH (NFPA)
Hose 7.5 Threads
Per Inch

* Compliance with the Standard for Hose Valves for Fire Protection Service, UL 668.

DIMENSIONS—WEIGHTS—QUANTITIES

Size	Dimensions						Weight		Box Qty.	Master Ctn. Qty.
	B		H		J		Lbs.	Kg.		
In. mm.	In.	mm.	In.	mm.	In.	mm.				
2½ 65	10.50	267	5.13	130	3.06	78	15.61	7.08	1	4

