

500 PSI WWP Iron Body Gate Valves

Fire Protection Valve • Bolted Bonnet • Outside Screw and Yoke •
Solid Wedge • Bronze Mounted • Class 250 Flanges

250 PSI/17.2 Bar Saturated Steam to 406° F/207° C

**500 PSI/34.5 Bar Non-Shock Cold Working Pressure
to -20° F to 150° F/-29° C to 66° C**

CONFORMS TO MSS SP-70 •

APPROVED BY THE NEW YORK CITY B.S.A. 143-69-SA
AT 350 PSI NON-SHOCK COLD WATER

MATERIAL LIST

PART	SPECIFICATION
1. Stem	Brass ASTM B16 Alloy C36000
2. Handwheel Nut	Cast Bronze ASTM B584 Alloy C84400
3. Identification Plate	Aluminum
4. Yoke Bushing	Cast Bronze ASTM B584 Alloy C84400
5. Handwheel	Cast Iron ASTM A126 Class B
6. Bonnet Cap Nut	Steel ASTM A307
7. Bonnet Cap	Cast Iron ASTM A126 Class B or Ductile Iron ASTM A536
8. ¹ Bonnet	Cast Iron ASTM A126 Class B
9. Bonnet Cap Bolt	Steel ASTM A307
10. Gland Follower Nut	Brass ASTM F467 Alloy C27000
11. Gland Follower	Cast Iron ASTM A126 Class B or Ductile Iron ASTM A536
12. Packing Gland	Zinc Plated Powdered Iron ASTM B783 or Brass ASTM B16
13. Packing	PTFE Braided
14. Gland Follower Bolt	Steel ASTM A307
15. Backseat Bushing	Cast Bronze ASTM B584 Alloy C84400
16. Body Nut	Steel ASTM A307
17. Body Gasket	Reinforced Graphite
18. Body Bolt	Steel ASTM A307
19. Body	Cast Iron ASTM A126 Class B
20. Stem Collar	Brass ASTM B16 Alloy C36000
21. ² Wedge	Cast Iron ASTM A126 Class B
22. ³ Wedge Nut	Cast Bronze ASTM B584 Alloy C84400
23. Wedge Pin	Silicon Bronze ASTM B371 Alloy C69400 or ASTM B140 Alloy C31400
24. Seat Ring	Cast Bronze ASTM B584 Alloy C84400
25. ² Wedge Face Ring	Cast Bronze ASTM B584 Alloy C84400

¹Sizes 2" thru 8" made with Yoke Integral with Bonnet. Sizes 8" thru 12" made with separate Yoke Bolted to Bonnet.

²Wedge construction - 2" thru 3" all bronze.
- 4" thru 12" Cast Iron with Bronze Wedge Face Rings.

³Bronze Wedge Nuts used on sizes 5" thru 12".

DIMENSIONS—WEIGHTS—QUANTITIES

Size	Dimensions										F-667-0 Weight		
	A		B		C		D		E		Lbs.	Kg.	
In. mm.	In.	mm.	In.	mm.	In.	mm.	In.	mm.	In.	mm.			
2	50	8.50	216	16.00	406	8	203	6.50	165	.88	22	56	25
2½	65	9.50	241	18.44	468	8	203	7.50	191	1.00	25	74	34
3	80	11.13	283	20.50	521	10	254	8.25	210	1.13	29	122	55
4	100	12.00	305	27.00	686	12	305	10.00	254	1.25	32	193	87
5	125	15.00	381	31.50	800	12	305	11.00	279	1.38	35	297	135
6	150	15.88	403	33.00	838	16	406	12.50	318	1.44	37	411	187
8	200	16.50	419	45.50	1156	16	406	15.00	381	1.63	41	637	289
10	250	18.00	457	56.00	1422	20	508	17.50	445	1.88	48	897	407
12	300	19.75	502	60.00	1524	20	508	20.50	521	2.00	51	1172	532



F-667-0
Flanged

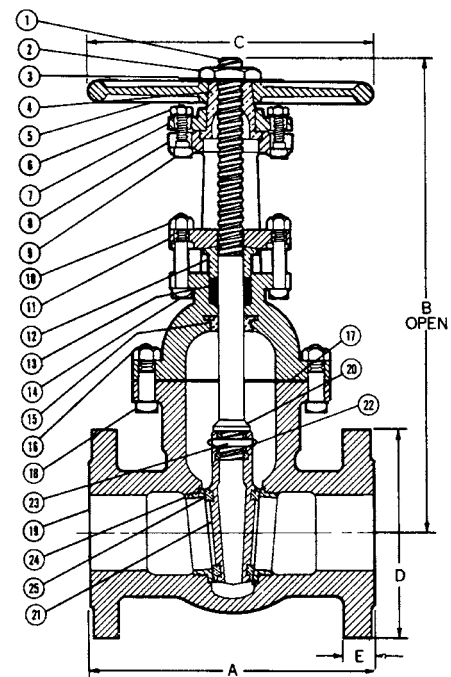

F-667-0
Flg x Flg

FREEZING WEATHER PRECAUTION: Subsequent to testing a piping system, valves should be left in an open position to allow complete drainage.