



Description & Features:

- Reliable, small diameter, low profile gauge
- 1" (25mm) to 1.5" (40mm) sizes
- 1/8" NPT socket
- Direct drive (no linkages or hairsprings) eliminating premature failure from the gear and movement
- Safety over-pressure port on the lens
- "Use No Oil" for use in oxygen service
- CRN registered
- UL Listed for 1.25" and 1.5" gauges
- 1 year warranty

Applications:

- Commonly used on portable pneumatic equipment such as compressors, hand-held sprayers, pressurized recreational guns, oxygen tanks and regulators, pumps and fire extinguishers

1 1/4" (32mm) and 1 1/2" (40mm)

UL252A Recognized Low pressures up to 1000 psi Listing No. **MH25761**

UL404 Listed High pressure - 0 to 3000 psi Listing No. **SA12053**

Specifications

Dial	1" (25mm), 1 1/8" (30mm), 1.25" (32mm) or 1.5" (40mm) white aluminum with black markings
Case	1" (25mm:): Nickel plated brass Others: 304 SS
Lens	Plexiglass
Spiral/Socket	60 to 2000 psi: Brass 3000 psi: Beryllium copper 4000 psi and above: 304 SS
Connection	1/8" NPT standard, back
Pointer	3000 psi and below: Brass 4000 psi and above: 304 SS
Over-Pressure Limit	10% of full scale value
Working Pressure	Maximum 75% of full scale value
Ambient/Process Temperature	-40°F to 150°F (-40°C to 6°C)
Accuracy	±3-2-3% ANSI/ASME Grade B
Enclosure Rating	IP65

Order Codes (products in bold are normally in stock)

Dial Size	1" (25mm)	1 1/8" (30mm)	1.25" (32mm)	1.5" (40mm)
0-60 psi	-	PSP115060	PSP125060	PSP150060
0-100 psi	PSP10100	PSP1150100	PSP1250100	PSP1500100
0-160 psi	PSP10160	PSP1150160	PSP1250160	PSP1500160
0-200 psi	PSP10200	PSP1150200	PSP1250200	PSP1500200
0-300 psi	PSP10300	PSP1150300	PSP1250300	PSP1500300
0-600 psi	PSP10600	PSP1150600	PSP1250600	PSP1500600
0-1,000 psi	PSP101000	PSP11501000	PSP12501000	PSP15001000
0-1,500 psi	PSP101500	PSP11501500	PSP12501500	PSP15001500
0-2,000 psi	PSP102000	PSP11502000	PSP12502000	PSP15002000
0-3,000 psi	PSP103000	PSP11503000	PSP12503000	PSP15003000
0-4,000 psi	PSP104000	PSP11504000	PSP12504000	PSP15004000
0-5,000 psi	PSP105000	PSP11505000	PSP12505000	PSP15005000

Option suffix for above order codes only:

1.25BOOT = 1.25" Protective Rubber Boot 1.5BOOT = 1.5" Protective Rubber Boot Other ranges available upon request

1" Spiral Hex Tube Gauge

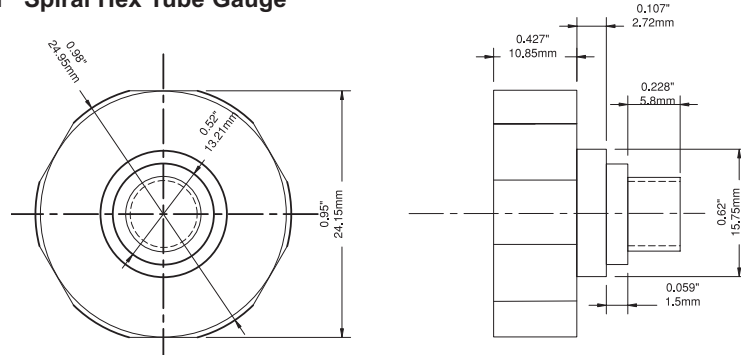

1 1/8" Spiral Tube Gauge

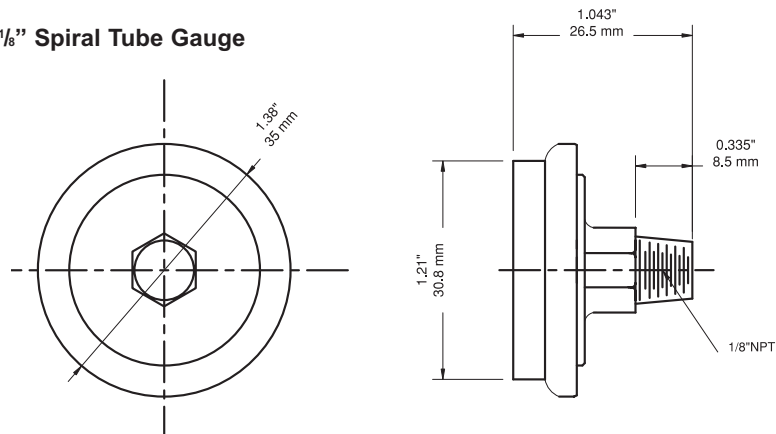

1.25" Spiral Tube Gauge

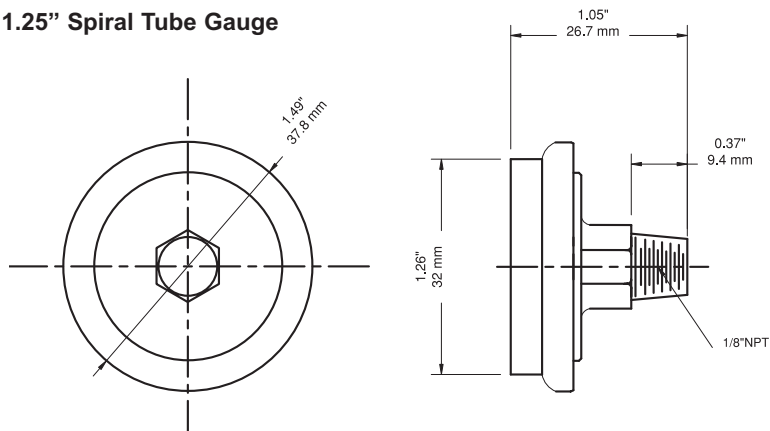

1.5" Spiral Tube Gauge

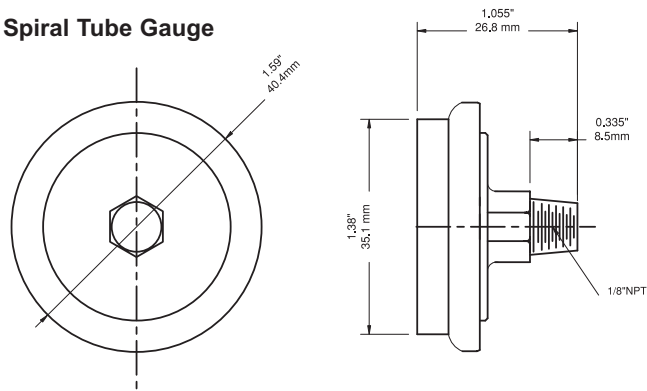

Series Number (for custom, non-standard product)

	P	S	P															
SERIES																		
DIAL SIZE																		
1" (25mm)				1	0													
1.125" (30mm)				1	2													
1.25" (32mm)				1	3													
1.5" (40mm)				1	5													
CASE MATERIALS																		
304SS							T											
WETTED PARTS																		
Brass								B										
316SS								S										
Special								Z										
CONFIGURATION																		
Back Connection, Stem Mounting									D									
Special									Z									
CONNECTION SIZE																		
1/8"																		
1/4"																		
Special																		
THREAD																		
NPT																		
BSP (G)																		
BSPT (R)																		
Special																		
PRIMARY SCALE																		
UNITS - See Page 13																		
RANGE - See Page 13																		
SECONDARY SCALE																		
UNITS - See Page 13																		
OPTIONS																		
Black Rubber Boot																		S Z
UL Approval																		U L
No Options																		X X