



1. Dry  
2. Liquid Filled

### Description & Features:

- 2.5" (63mm) to 6" (150mm) durable gauges
- 2.5" (63mm) dial have a blue and red coloured case for easy identification
- Dual scale (psi/°F)
- Flutterless movement on the 2.5" (63mm)
- Chlorofluorocarbon (CFC) temperature scales (R-12, R-22 & R-502)
- Brass internals
- 1/4" NPT standard
- CRN registered
- 3 year warranty

### Applications:

- Refrigeration equipment and refrigeration recovery equipment

Specifications	
<b>Dial</b>	2.5" (63mm), 4" (100mm), 6" (150mm): White aluminum 2.5" (63mm) liquid filled: Multicolored dial
<b>Case</b>	2.5" (63mm): Plastic, colour coded, blue for low pressure and red for high pressure 4" (100mm), 6" (150mm): Steel painted black
<b>Lens</b>	2.5" (63mm): Plexiglass, threaded (liquid filled: Polycarbonate lens) 4" (100mm), 6" (150mm): Glass 2.5" (63mm) liquid filled: Nylon/glass filled
<b>Ring</b>	2.5" (63mm) liquid filled SS, crimped 4" (100mm): Brass, polished 6" (150mm): Steel, painted black
<b>Connection</b>	1/8" NPT or 1/4" NPT standard
<b>Restrictor Screw</b>	Standard
<b>Recalibrator Screw</b>	Standard (2.5" (63mm) liquid filled has external recalibrator)
<b>Bourdon Tube</b>	2.5" (63mm): Phosphor bronze, vibration free (flutterless movement - dry only) 4" (100mm), 6" (150mm): Phosphor bronze
<b>Pointer</b>	Aluminum, anodized black 2.5" (63mm) liquid filled: Red aluminum, anodized
<b>Welding</b>	#50 tin solder
<b>Over-Pressure Limit</b>	25% of full scale value
<b>Scale</b>	psi/F (R-12/R-22/R-502)
<b>Working Pressure</b>	Maximum 75% of full scale value
<b>Ambient/Process Temperature</b>	2.5" (63mm), 4" (100mm), 6" (150mm): -40°F to 158°F (-40°C to 70°C) 2.5" (63mm) liquid filled: -13°F to 140°F (-25°C to 60°C)
<b>Accuracy</b>	2.5" (63mm): ±2% ANSI/ASME Grade B 4" (100mm), 6" (150mm): ±1% ANSI/ASME Grade A
<b>Enclosure Rating</b>	Dry: IP52 Liquid Filled: IP65

### Order Codes (products in bold are normally in stock)

Dial Size	2.5" (63mm)			4" (100mm)		6" (150mm)	
Connection	1/8" NPT Bottom	1/8" NPT Back	1/8" NPT Bottom	1/4" NPT Bottom	1/4" NPT Back	1/4" NPT Bottom	1/4" NPT Back
Case	Plastic	Plastic	Plastic Liquid Filled	Steel	Steel	Steel	Steel
30"/0/120 psi (retard 250)	<b>PFG1730</b>	-	<b>PFG1760</b>	<b>PFG1734</b>	-	PFG1738	-
30"/0/300 psi	PFG1731	-	PFG1761	<b>PFG1735</b>	-	PFG1739	-
0-500 psi	PFG1732	-	PFG1762	PFG1736	-	PFG1740	-

Note: Other connection and ranges available upon request  
Blister packaging available

### 2.5" Bottom Connection

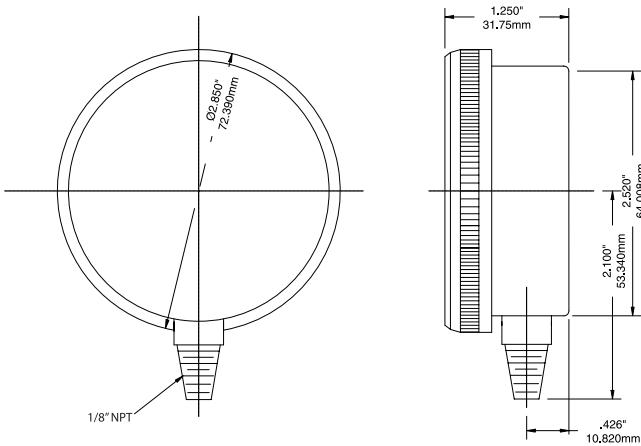

### 2.5" Bottom Connection Liquid Filled

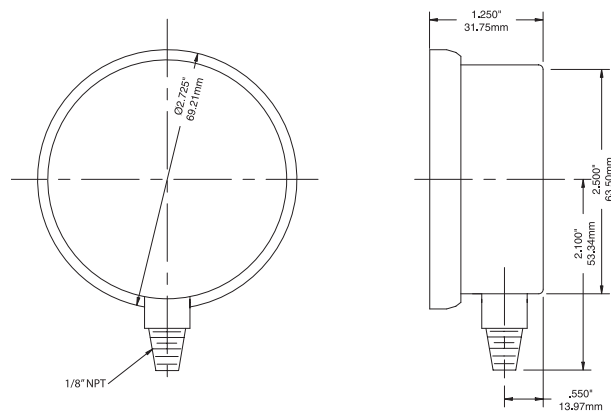

### 4" Bottom Connection

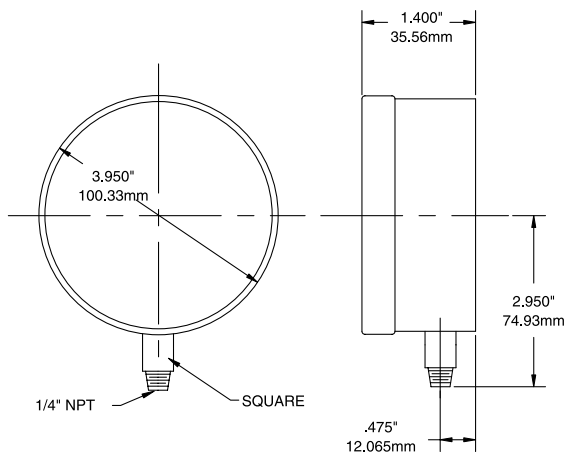

### 6" Bottom Connection

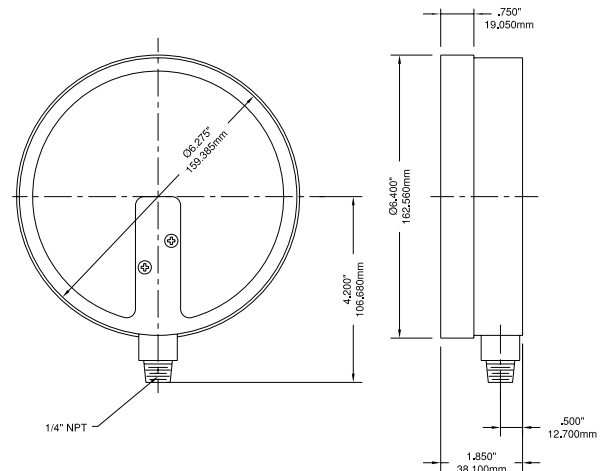

## Series Number (for custom, non-standard product)

	P	F	G	-	-	-	-	-	-	-	-	-	-	-	-	-	-	-	-
<b>SERIES</b>																			
<b>DIAL SIZE</b>																			
2.5" (63mm)					2	5													
4.0" (100mm)					4	0													
4.5" (115mm)					4	5													
6.0" (150mm)					6	0													
8.5" (215mm)					8	5													
10.0" (250mm)					9	0													
<b>CASE MATERIALS</b>																			
304SS							T												
316SS							S												
Aluminum							A												
Phenolic							F												
Plastic (PBT)							U												
Steel Painted Black							Y												
<b>WETTED PARTS</b>																			
Brass								B											
316SS								S											
Monel								M											
Special								Z											
<b>CONFIGURATION</b>																			
Bottom Connection, Stem Mounting									A										
Bottom Connection, Back Flange, Surface Mounting									B										
Bottom Connection, Front Flange, Surface Mounting									C										
Back Connection, Stem Mounting									D										
Back Connection, Back Flange, Surface Mounting									E										
Back Connection, Wide Front Flange, (Drilled) Panel Mounting									F										
Back Connection, Wide Front Flange, (Undrilled) Panel Mounting									U										
Back Connection, Narrow Front Ring, Panel Mounting (Yoke)									V										
Special									Z										
<b>CONNECTION SIZE</b>																			
1/8"										8									
1/4"										4									
3/8"										3									
1/2"										2									
Special										Z									
<b>THREAD</b>																			
NPT											N								
BSP (G)											B								
BSPT (R)											T								
Special											Z								
PRIMARY SCALE																			
<b>UNITS - See Page 13</b>																			
<b>RANGE - See Page 13</b>																			
SECONDARY SCALE																			
<b>UNITS - See Page 13</b>																			
<b>OPTIONS</b>																			
Black Rubber Boot	S		Z																U
Blowout Disk	S		B																L
Fluorolube Filled	S		R																D
Flush Mounting Ring	S		P																A
Glycerin Filled	S		E																I
Halocarbon Filled	S		Q																M
Hinged Case	S		T																3
Maximum Adjustable Pointer	S		J																O
Monel Socket and Tube	S		W																X
Over and Understops																			
Oxygen Cleaning																			
Silicone Filled																			
Safety Glass																			
Solid Front Safety Case with Safety Glass																			
Stainless Steel Tag Plate																			
Stabilizer Movement																			
Test Certificate																			
No Options																			