

PSI Industrial Sanitary Gauge Assembly



1. Crimp-On Ring Style
(shown with optional liquid fill)
2. Bayonet Ring Style
(shown with optional liquid fill)

Description & Features:

- Stainless steel gauge case
- Glycerin filled seal
- Brass or stainless steel internals
- CRN registered
- 1 year warranty

Applications:

- To prevent any clogging of viscous materials (i.e. paint, ink, heavy/thick liquids) that may solidify

Specifications - Gauge	Crimp-On Ring Style	Bayonet Ring Style
Dial	2.5" (63mm), 4" (100mm), white aluminum with black and red markings	2.5" (63mm), 4" (100mm) white aluminum with black and red markings
Case	AISI 304 SS	AISI 304 SS
Lens	Polycarbonate	Polycarbonate
Ring	AISI 304 SS	AISI 304 SS
Socket	OT 58 brass or AISI 316 SS	316L SS
Connection	1/4" NPT standard with restricted orifice	1/4" NPT
Bourdon Tube	Phosphor bronze C-shaped for pressures up to and including 600 psi (4,147 kPa) unless SS internals are specified AISI 316 SS C-shaped for 1000 psi (6,895 kPa)	316L SS, drawn seamless
Movement	OT 59 brass or SS	304 SS Over/under stops for 4" (100mm) dial only
Pointer	Aluminum, anodized black	2.5" (63mm): Aluminum, anodized black 4" (100mm): Aluminum, anodized black, micrometer adjustable
Welding	Tin/copper alloy for pressures below 600 psi (4,147 kPa), 316 SS TIG Argon arc for pressures 600 psi (4,147 kPa) and above	TIG
Over-Pressure Limit	25% for pressures up to 600 psi (9,653 kPa)	30% for pressures up to 600 psi (4,147 kPa) 15% for pressures over 600 psi (4,147 kPa)
Gasket Material	Silicone rubber for socket EPDM for lens, filling plug and blow-out vent	2.5" (63mm): Buna N for case and block seal, Monoprene for lens seal 4" (100mm): EPDM
Working Pressure	Maximum 75% of full scale value	Maximum 75% of full scale value
Ambient/Process Temperature	-40°F to 150°F (-40°C to 65°C) dry, -4°F to 150°F (-20°C to 65°C) liquid filled	-40°F to 150°F (-40°C to 65°C) dry, -4°F to 150°F (-20°C to 65°C) liquid filled
Accuracy	±1.5% ANSI/ASME Grade B	2.5" (63mm): ±1.5% ANSI/ASME Grade B 4" (100mm): ±1% ANSI/ASME Grade A
Enclosure Rating	IP65	IP66 per UEC 529, UNI 8896

Specifications - Seal	
Housing	AISI 316 SS
Diaphragm	AISI 316L SS, welded
Fill Liquid	Glycerin
Minimum Operating Pressure	30 psi (200 kPa)
Maximum Operating Pressure	1,000 psi (6,900 kPa)
Gauge Connection	1/4" NPT female
Process Connection	1.5" (40mm) and 2" (50mm), Tri-Clamp® fitting standard
Process Temperature	-4°F to 248°F (-20°C to 120°C)
Surface Finish	8 Ra

2.5" Crimp-On Ring Style Bottom Connection with 1.5" Tri-Clamp®

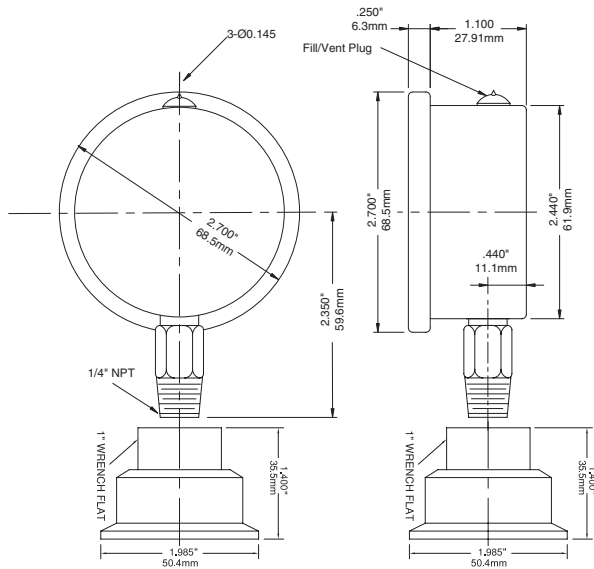

2.5" Crimp-On Ring Style Back Connection with 1.5" Tri-Clamp®

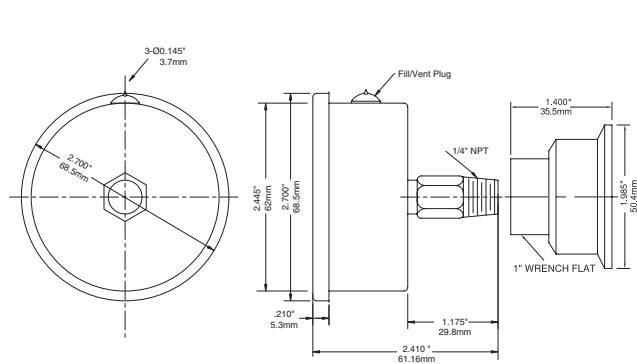

4" Crimp-On Ring Style Bottom Connection with 2" Tri-Clamp®

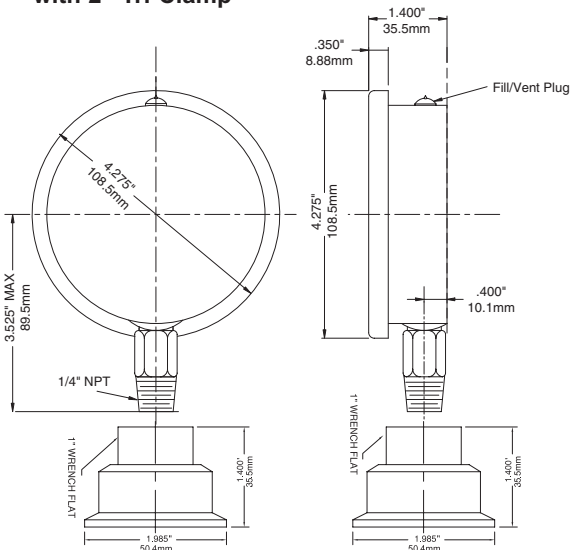

4" Crimp-On Ring Style Back Connection with 2" Tri-Clamp®

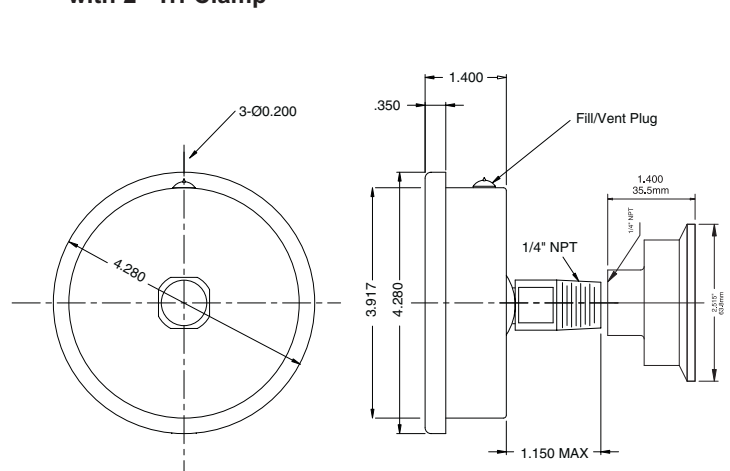

Tri-Clamp® is a registered trademark of Tri-Clover, Inc.

2.5" Bayonet Ring Style Bottom Connection with 1.5" Tri-Clamp®

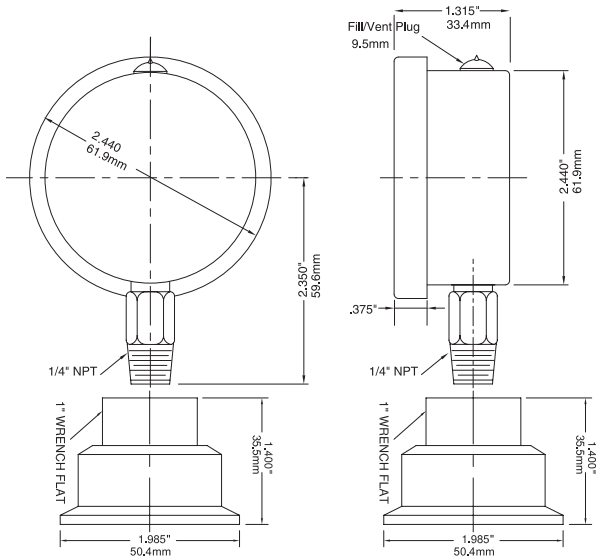

2.5" Bayonet Ring Style Back Connection with 1.5" Tri-Clamp®

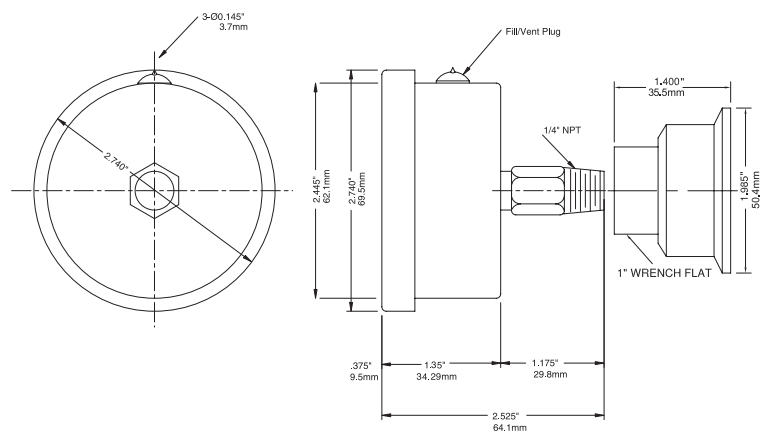

4" Bayonet Ring Style Bottom Connection with 2" Tri-Clamp®

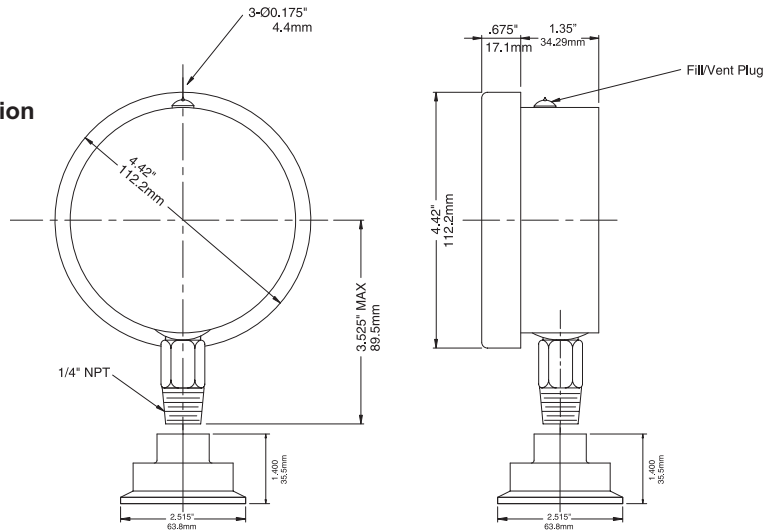

4" Bayonet Ring Style Back Connection with 2" Tri-Clamp®

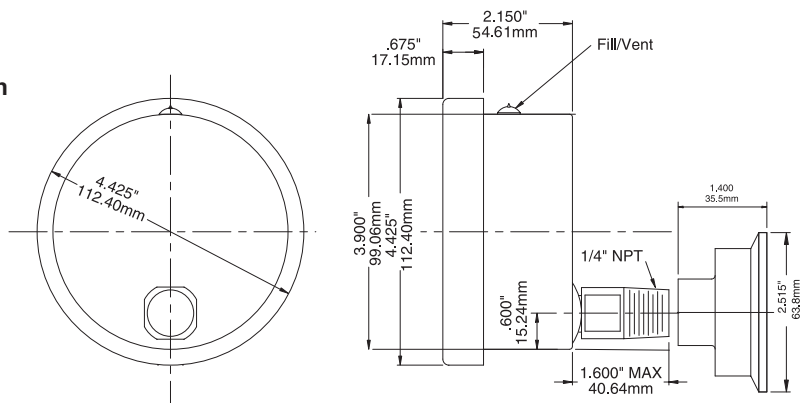

Tri-Clamp® is a registered trademark of Tri-Clover, Inc.

Series Number (for custom, non-standard product)

	P	S	I															
SERIES																		
DIAL SIZE																		
2.5" (63mm)					2	5												
4.0" (100mm)					4	0												
CASE MATERIALS																		
304SS																		T
316SS																		S
GAUGE INTERNALS																		
Brass																		B
316SS																		S
BEZEL RING																		
Bayonet Ring																		B
Crimped On Ring																		C
CONNECTION																		
Bottom																		A
Back																		D
SANITARY SEAL																		
1.5" Tri- Clamp																		D 1
2" Tri-Clamp																		D 2
PRIMARY SCALE																		
UNITS - See Page 13																		
RANGE - See Page 13. Only ranges 30 to 1000 psi available																		
SECONDARY SCALE																		
UNITS - See Page 13																		
ACCURACY																		
2.5" Dial 1.6%																		1 5
4" Dial 1.6%																		1 5
4" Dial 1%																		1 0
OPTIONS																		
Dry - no fill in case																		N F
Acrylic lens																		S V
Fluorolube Filled																		S R
Glycerin Filled																		S E
Halocarbon Filled																		S Q
Silicone Filled																		S D
Safety Glass																		S A
Stainless Steel Tag Plate																		S M
Test Certificate																		S O
No Options																		X X