

Description & Features:

- Stabilizer dampened movement minimizes effects of pulsation and vibration without liquid filling (flutterless pointer)
- Restricted orifice
- Crimp-on bezel
- Brass internals
- Dual scale (psi/kPa)
- U-Clamps and front flanges for panel mounting
- 3 year warranty

Applications:

- Ideal for pumps, compressors, hydraulic presses, machinery and motors that operate in harsh environments

Order Codes (products in bold are normally in stock)

Specifications	
Dial	2.5" (63mm) aluminum with red and black markings
Case	304 SS (dry)
Lens	Polycarbonate
Ring	304 SS (crimped on)
Socket	Brass
Connection	1/4" NPT with restricted orifice
Bourdon Tube	Bronze
Movement	Bronze with Stabilizer
Pointer	Anodized black aluminum
Over-Pressure Limit	15% of full scale
Gasket Material	Neoprene
Working Pressure	75% of full scale
Ambient/Process Temperature	-40°F to 150°F (-40°C to 65°C)
Accuracy	±1.5% ANSI/ASME Grade B
Enclosure Rating	IP65

Option suffix for above order codes only:

- 25BF = 2.5" (63mm) back flange
- 25UC = U-Clamp for panel mounting
- 25BOOT = Protective black rubber boot
- 25FF = Flange for panel mounting

Dial Size	2.5 (63mm)	
	1/4" Bottom	1/4" Back (CB)
30" Hg Vacuum/kPa	PST801Z	PST900Z
30"-0-15 psi/kPa	PST790Z	PST890Z
30"-0-30 psi/kPa	PST798Z	PST898Z
30"-0-60 psi/kPa	PST799Z	PST899Z
30"-0-100 psi/kPa	PST791Z	PST891Z
30"-0-150 psi/kPa	PST792Z	PST892Z
30"-0-200 psi/kPa	PST794Z	PST894Z
30"-0-300 psi/kPa	PST795Z	PST895Z
0-15 psi/kPa	PST800Z	PST901Z
0-30 psi/kPa	PST802Z	PST902Z
0-60 psi/kPa	PST803Z	PST903Z
0-100 psi/kPa	PST804Z	PST904Z
0-160 psi/kPa	PST805Z	PST905Z
0-200 psi/kPa	PST806Z	PST906Z
0-300 psi/kPa	PST807Z	PST907Z
0-400 psi/kPa	PST817Z	PST917Z
0-600 psi/kPa	PST808Z	PST908Z
0-1,000 psi/kPa	PST809Z	PST909Z
0-1,500 psi/kPa	PST816Z	PST914Z
0-2,000 psi/kPa	PST810Z	PST910Z
0-3,000 psi/kPa	PST811Z	PST911Z
0-5,000 psi/kPa	PST812Z	PST912Z
0-6,000 psi/kPa	PST814Z	PST915Z
0-7,500 psi/kPa	PST818Z	PST918Z
0-10,000 psi/kPa	PST813Z	PST913Z

2.5" (63mm), Back Connection, U-Clamp

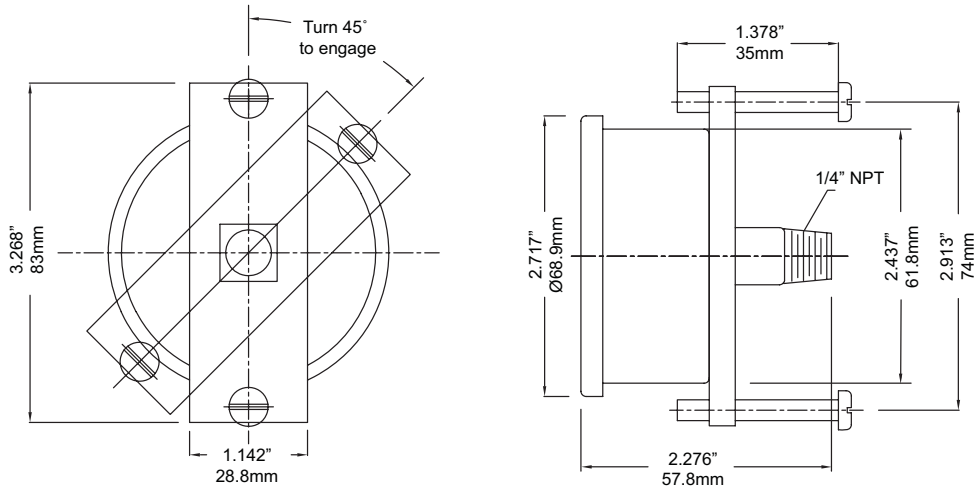

2.5" (63mm), Back Connection, Front Flange

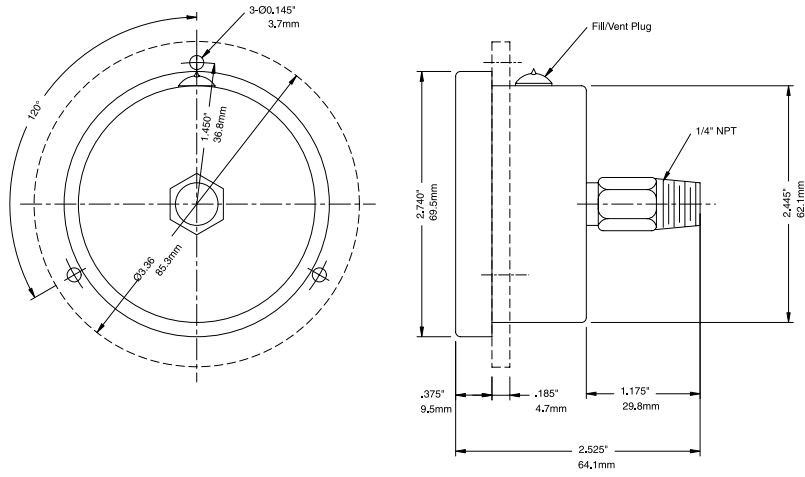

2.5" (63mm), Back Flange Bottom

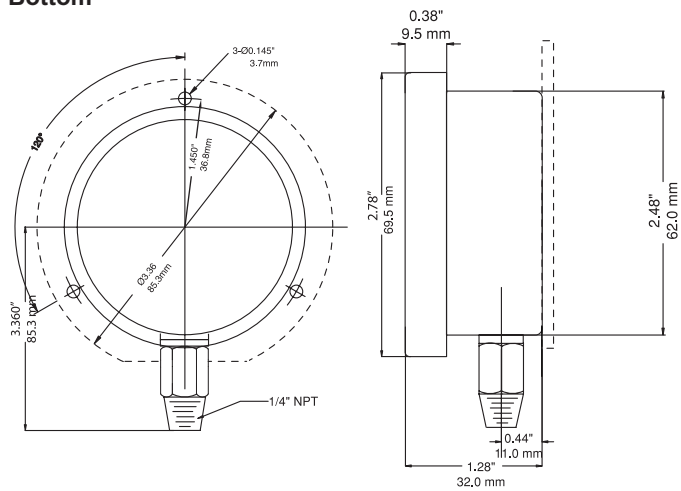

Series Number (for custom, non-standard product)

	P	S	T																
SERIES																			
DIAL SIZE																			
2.5" (63mm)					2	5													
4.0" (100mm)					4	0													
CASE MATERIALS																			
304SS																			
316SS																			
WETTED PARTS																			
Brass																			
316SS																			
CONFIGURATION																			
Bottom Connection, Stem Mounting																			
Bottom Connection, Back Flange, Surface Mounting																			
Bottom Connection, Front Flange, Surface Mounting																			
Back Connection, Stem Mounting																			
Back Connection, Back Flange, Surface Mounting																			
Back Connection, Wide Front Flange, (Drilled) Panel Mounting																			
Back Connection, Wide Front Flange, (Undrilled) Panel Mounting																			
Back Connection, Narrow Front Ring, Panel Mounting (Yoke)																			
Special																			
CONNECTION SIZE																			
1/8"																			
1/4"																			
3/8"																			
1/2"																			
Special																			
THREAD																			
NPT																			
BSP (G)																			
BSPT (R)																			
M14 x 1.5																			
M20 x 1.5																			
Special																			
PRIMARY SCALE																			
UNITS - See Page 13																			
RANGE - See Page 13																			
SECONDARY SCALE																			
UNITS - See Page 13																			
OPTIONS																			
Black Rubber Boot																			
Blowout Disk																			
Maximum Adjustable Pointer																			
Oxygen Cleaning																			
Safety Glass																			
Stainless Steel Tag Plate																			
Test Certificate																			
No Options																			