



### Description & Features:

- Premium aluminum case gauge designed to read head pressure
- Stainless steel or brass wetted parts
- PSI and Feet of Water scales
- CRN registered
- 5 year warranty

### Applications:

- Used to indicate liquid level in tank or stand pipe, etc.
- Economical alternative for level measurement

Specifications	Stainless Steel Internals	Brass Internals
Dial	4.5" (115mm)	4.5" (115mm)
Case	Aluminum painted black	Aluminum painted black
Front Flange	SS, polished	SS, polished
Back Flange	Steel, painted black	Steel, painted black
Lens	Glass	Glass
Ring	SS, polished	SS, polished
Socket	316L SS	Brass
Connection	1/4" NPT or 1/2" NPT standard	1/4" NPT or 1/2" NPT standard
Bourdon Tube	316L SS	Phosphor bronze
Movement	SS	Brass
Pointer	Aluminum, anodized black, micrometer adjustable	Aluminum, anodized black, micrometer adjustable
Welding	316L SS TIG Argonarc	Tin/copper alloy
Over-Pressure Limit	30% of full scale value	30% of full scale value
Working Pressure	Maximum 75% of full scale value	Maximum 75% of full scale value
Ambient/Process Temperature	-40°F to 150°F (-40°C to 65°C)	-40°F to 150°F (-40°C to 65°C)
Accuracy	±0.5% ANSI/ASME Grade 2A	±0.5% ANSI/ASME Grade 2A
Enclosure Rating	IP52	IP52

### Order Codes

Dial Size	4.5" (115mm)	
Movement, Socket, Tube	Brass	SS
0-35 ft/water	PAL6008ALT	PAL6033ALT
0-70 ft/water	PAL6009ALT	PAL6034ALT
0-140 ft/water	PAL6010ALT	PAL6035ALT
0-230 ft/water	PAL6011ALT	PAL6036ALT
0-370 ft/water	PAL6012ALT	PAL6037ALT
0-460 ft/water	PAL6013ALT	PAL6038ALT
0-690 ft/water	PAL6014ALT	PAL6039ALT

### Option suffix for above order codes only:

SG-45 = Safety glass lens

MS = Monel® socket and tube

SFC = Solid front safety case

300BF = Back flange

OST = Over stop protection

MAXI45 = Maximum adjustable pointer available

UST = Under stop protection

Other ranges, dial sizes, gauge types, options and connections are available upon request

Note: For back connection, add the suffix "B" to the corresponding bottom connection order codes. Front flange is standard on all back connection models

### 4.5" Bottom Connection with Standard Back Flange

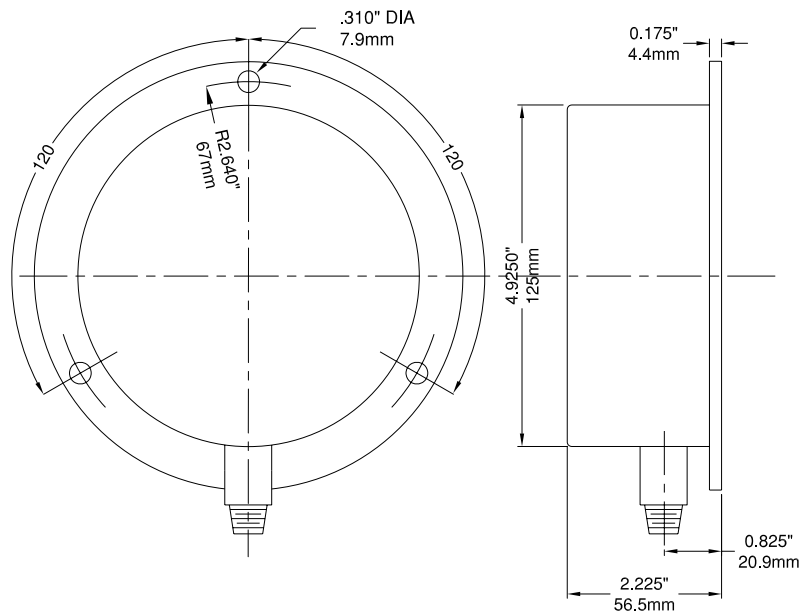

Monel® is a registered trademark of Inco Alloys International

## Series Number (for custom, non-standard product)

	P	A	L															
<b>DIAL SIZE</b>																		
2.5" (63mm)					2	5												
3.0" (75mm)					3	0												
3.5" (90mm)					3	5												
4.0" (100mm)					4	0												
4.5" (115mm)					4	5												
6.0" (150mm)					6	0												
8.5" (215mm)					8	5												
10.0" (250mm)					9	0												
<b>CASE MATERIALS</b>																		
304SS							T											
316SS							S											
Aluminum							A											
Brass							B											
Phenolic							F											
Plastic (PBT)							U											
Steel Painted Black							Y											
<b>WETTED PARTS</b>																		
Brass								B										
316SS								S										
Monel								M										
Special								Z										
<b>CONFIGURATION</b>																		
Bottom Connection, Stem Mounting									A									
Bottom Connection, Back Flange, Surface Mounting									B									
Bottom Connection, Front Flange, Surface Mounting									C									
Back Connection, Stem Mounting									D									
Back Connection, Back Flange, Surface Mounting									E									
Back Connection, Wide Front Flange, (Drilled) Panel Mounting									F									
Back Connection, Narrow Front Ring, Panel Mounting (Yoke)									V									
Special									Z									
<b>CONNECTION SIZE</b>																		
1/8"										8								
1/4"										4								
3/8"										3								
1/2"										2								
Special										Z								
<b>THREAD</b>																		
NPT											N							
BSP (G)											B							
BSPT (R)											T							
M14 x 1.5											F							
M20 x 1.5											M							
Special											Z							
PRIMARY SCALE																		
<b>UNITS - See Page 13</b>																		
<b>RANGE - See Page 13</b>																		
SECONDARY SCALE																		
<b>UNITS - See Page 13</b>																		
<b>OPTIONS</b>																		
Acrylic lens	S	V													S	U		
Black Rubber Boot	S	Z													S	L		
Blowout Back	S	X													S	D		
Blowout Disk	S	B													S	A		
Fluorolube Filled	S	R													S	I		
Glycerin Filled	S	E													S	M		
Halocarbon Filled	S	Q													S	3		
Hinged Case	S	T													S	O		
Maximum Adjustable Pointer	S	J													X	X		