

## 105A

## 1:5 Stereo Audio Distribution Amplifier



The **105A** is a high-performance distribution amplifier for unbalanced stereo audio signals. It takes one stereo input and distributes the signal to five identical stereo outputs.

## FEATURES

- Level (Gain) Controls.
- S/N Ratio - 80dB (unweighted).
- Compact Kramer TOOLS™ - 3 units can be rack mounted side-by-side in a 1U rack space with the optional RK-3T rack adapter.

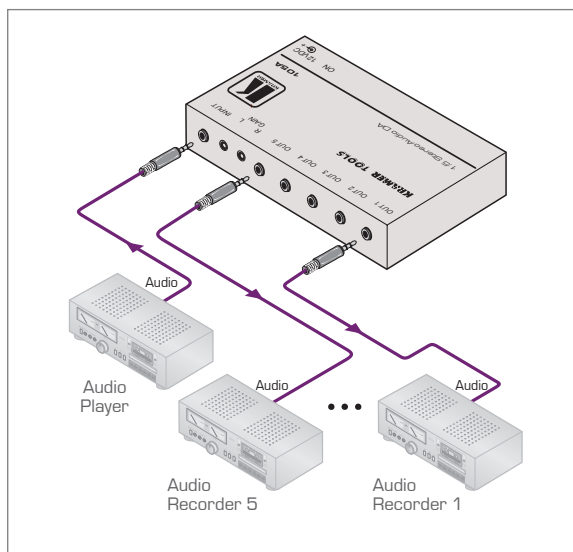

## TECHNICAL SPECIFICATIONS

INPUT:	1 unbalanced stereo/balanced mono, 1Vpp/33kΩ on a 3.5mm mini jack.
OUTPUTS:	5 unbalanced stereo/balanced mono, 1Vpp/50Ω on 3.5mm mini jacks.
MAX. OUTPUT:	5Vpp (> +4dBu).
AUDIO BANDWIDTH (-3dB):	20kHz.
S/N RATIO:	80dB unweighted.
CONTROL:	Left and right gain rear trimmers (0 to +3.5dB).
COUPLING:	AC.
THD:	0.03% (2nd harmonic).
POWER SOURCE:	12V DC, 100mA.
DIMENSIONS:	12cm x 7.5cm x 2.5cm (4.7" x 2.95" x 0.98") W, D, H.
WEIGHT:	0.28kg (0.62lbs) approx.
ACCESSORIES:	Power supply, mounting bracket.
OPTIONS:	RK-3T 19" rack adapter.

