

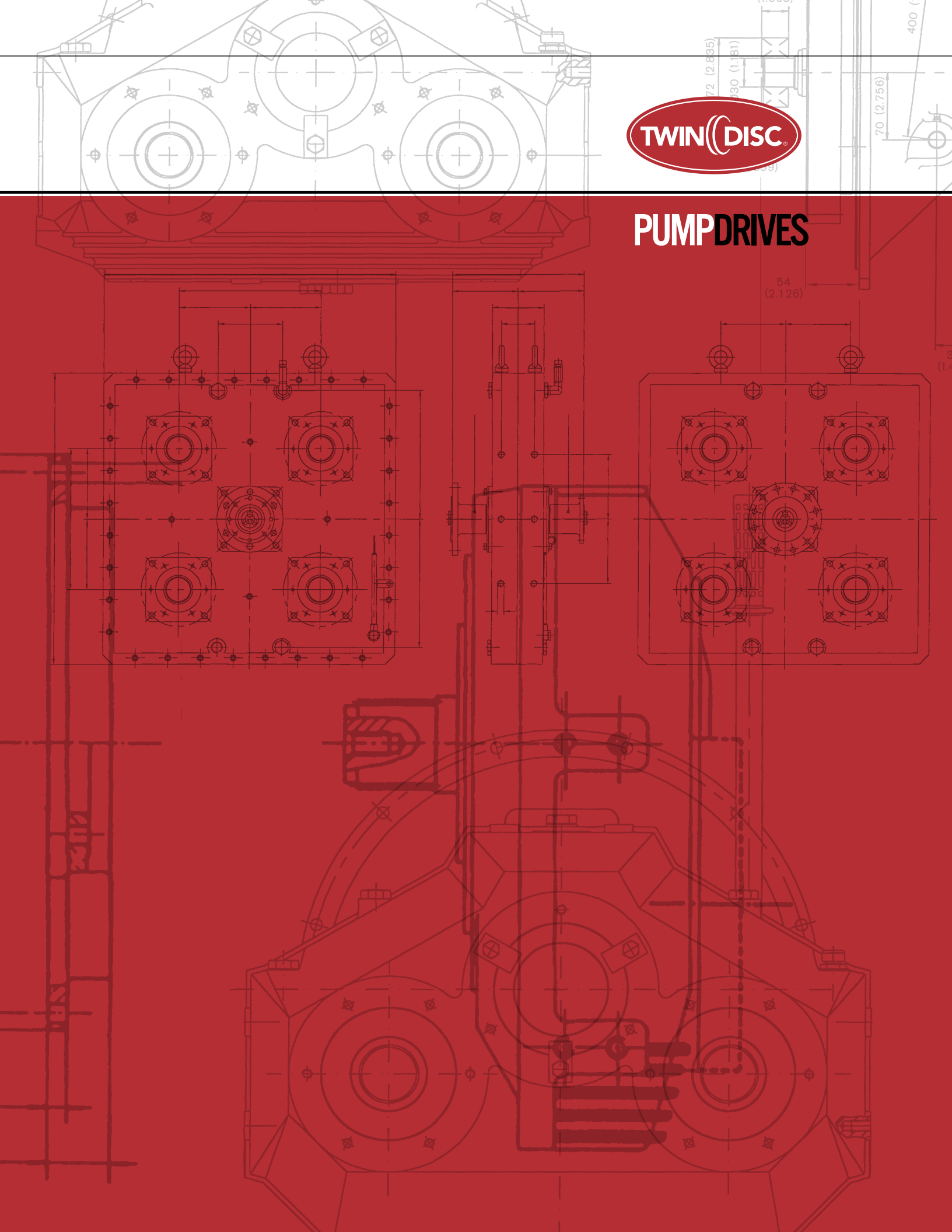

PUMP DRIVES

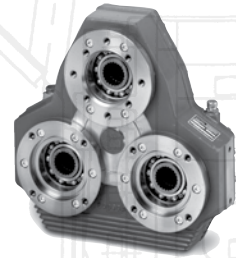

A NEW LINE OF PUMP DRIVES FROM TWIN DISC



Twin Disc is pleased to offer a new line of pump drives to meet your hydraulic system needs. These drives are available in a wide variety of gear ratios, including both speed increasing and reducing configurations.

The modular design of these pump drives enables you to choose from a variety of input options including a flex plate, rubber block drive, or clutch to match your SAE engine flywheel dimensions. Independent mounting is also an option, both direct or with a clutch.

For your pump mounting requirements, Twin Disc offers standard SAE adaptor kits as well as a wide variety of non-SAE adaptations for your special needs.

With models having one, two, three, four or six pump pads, Twin Disc is sure to have a pump drive to complement your hydraulic application. For your convenience, the number of pump pads is indicated by the first numeral after the “AM” designation in the pump drive model numbers. Models AM 232, AM 365, AM 450, and AM 480 also have additional pump pads available on the input side of the pump drives.

TWIN DISC PUMP DRIVES INCLUDE THE FOLLOWING DESIGN FEATURES

- Cast iron housings
- Case hardened and ground spur gears, except AM 216—AM 320 series where gears are shaved
- Ball bearings
- Case hardened shafts
- Viton seals on input shaft
- Output rotation opposite the direction of input rotation
- Gear ratios identical on all outputs
- Maximum input torque based on theoretically unlimited gear life and a minimum L10 bearing life of 10,000 hours

DIRECT DRIVE SINGLE PUMP ADAPTORS	2
CLUTCH COUPLED SINGLE PUMP ADAPTORS	3
up to 242 kW (325 hp) AM 110	4–5
up to 220 kW (295 hp) AM 216	6–7
up to 215 kW (285 hp) AM 320	8–9
up to 430 kW (580 hp) AM 220	10–11
up to 375 kW (500 hp) AM 330	12–13
AM 216-320-220-330 OPTION SELECTION	14–15
up to 495 kW (660 hp) AM 230	16–17
up to 570 kW (765 hp) AM 232	18–19
up to 775 kW (1010 hp) AM 345	20–21
up to 965 kW (1295 hp) AM 450	22–23
AM 230-232-345-450 OPTION SELECTION	24–25
up to 885 kW (1185 hp) AM 365	26
up to 705 kW (945 hp) AM 480	27
SAE HYDRAULIC PUMP STANDARD	28
SAE ENGINE FLYWHEEL HOUSING AND MATING HOUSING FLANGES	30
SAE ENGINE FLYWHEEL STANDARD	32
PUMP DRIVE SELECTION PROCEDURE	34
TECHNICAL INFORMATION	34
SERVICE FACTORS	34
LUBRICATION	34
THERMAL CAPACITY	34
INSTALLATION GUIDELINES	35
FLUID POWER FORMULAS	INSIDE BACK COVER

DIRECT DRIVE SINGLE PUMP ADAPTORS

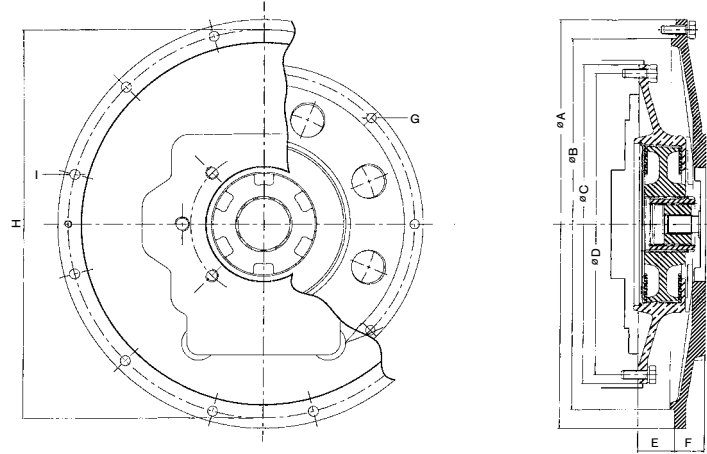

HOUSING DIMENSIONS

	A mm (in)	B mm (in)	H mm (in)	I mm (in)	F mm (in)
SAE 5	356 (14.016)	314.32 (12.375)	333.37 (13.125)	11 (0.433)	35.5 (1.398)
SAE 4	403 (15.866)	361.95 (14.250)	381.00 (15.000)	11 (0.433)	33.0 (1.299)
SAE 3	451 (17.756)	409.57 (16.125)	428.62 (16.875)	11 (0.433)	33.0 (1.299)
SAE 2	489 (19.252)	447.68 (17.625)	466.72 (18.375)	11 (0.433)	50.0 (1.969)
SAE 1	552 (21.732)	511.17 (20.125)	530.22 (20.875)	12 (0.472)	50.0 (1.969)

COUPLING HOUSING

	6.5" mm (in)	7.5" mm (in)	8" mm (in)	10" mm (in)	11.5" mm (in)
C	215.90 (8.500)	241.30 (9.500)	263.52 (10.375)	314.32 (12.375)	352.42 (13.875)
D	200.02 (7.875)	222.25 (8.750)	244.47 (9.625)	295.27 (11.625)	333.37 (13.125)
E	30.20 (1.189)	30.20 (1.189)	61.90 (2.437)	53.80 (2.118)	39.60 (1.559)
G	9.00 (0.354)	9.00 (0.354)	10.50 (0.413)	10.50 (0.413)	10.50 (0.413)

MAXIMUM CONTINUOUS TORQUE RATING N-m (lb-ft)

6.5"	7.5"	8"	10"	11.5"
300 (221)	300 (221)	300 (221)	300 (221)	650 (479)

PUMP ADAPTATIONS

SAE A, B, C and D. Other configurations may be available. Contact Twin Disc, Incorporated.

CLUTCH COUPLED SINGLE PUMP ADAPTORS

BDP ENGINE MOUNTED

PUMP	
	X mm (in)
SAE B	20 (0.787)
SAE C	28 (1.102)

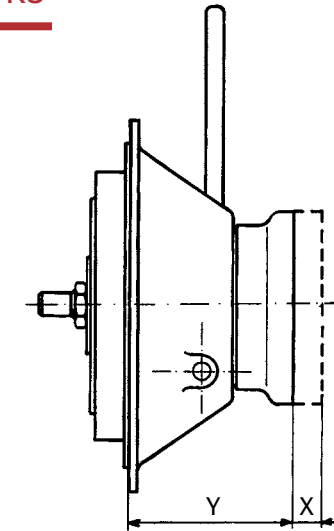

TYPE	HOUSING	SIZE	MAX. TORQUE	MAX. SPEED RPM	MAX. POWER kW (hp)	Y mm (in)
BDP 145	3-4	11.5"	450 (332)	3100	80 (107)	174 (6.850)
BDP 290	1-2-3	11.5"	900 (664)	2850	150 (201)	207 (8.150)

BDSP REMOTELY MOUNTED

PUMP	
	X mm (in)
SAE B	20 (0.787)
SAE C	28 (1.102)

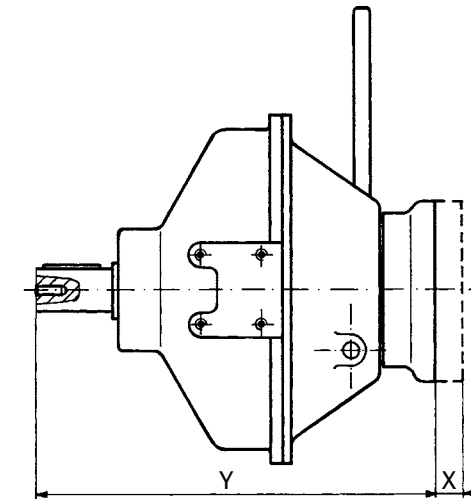

TYPE	MAX TORQUE	MAX SPEED RPM	MAX POWER kW (hp)	MAX SPEED RPM	Y mm (in)
BDP 145	450 (332)	3100	80 (107)	3100	462 (18.189)
BDP 290	900 (664)	2850	150 (201)	2850	495 (19.488)

Other sizes are available on request. Contact Twin Disc, Incorporated.

AM 110 MAXIMUM INPUT POWER 242 kW (325 hp)

BASIC PUMP DRIVE
AM 110 B

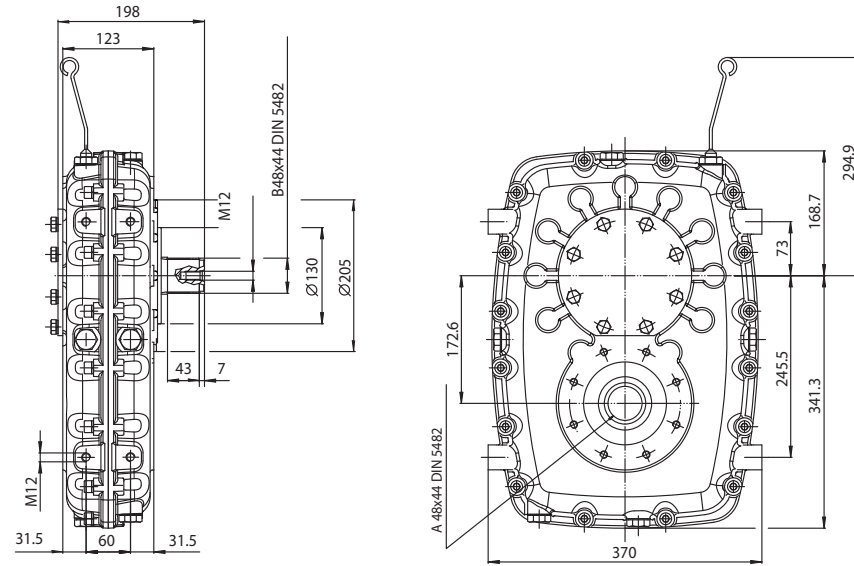

WITH ONE PLATE 10" CLUTCH
AM 110 BD 130

WITH ONE PLATE 11" CLUTCH
AM 110 BD 145

WITH TWO PLATE 11" CLUTCH
AM 110 BD 290

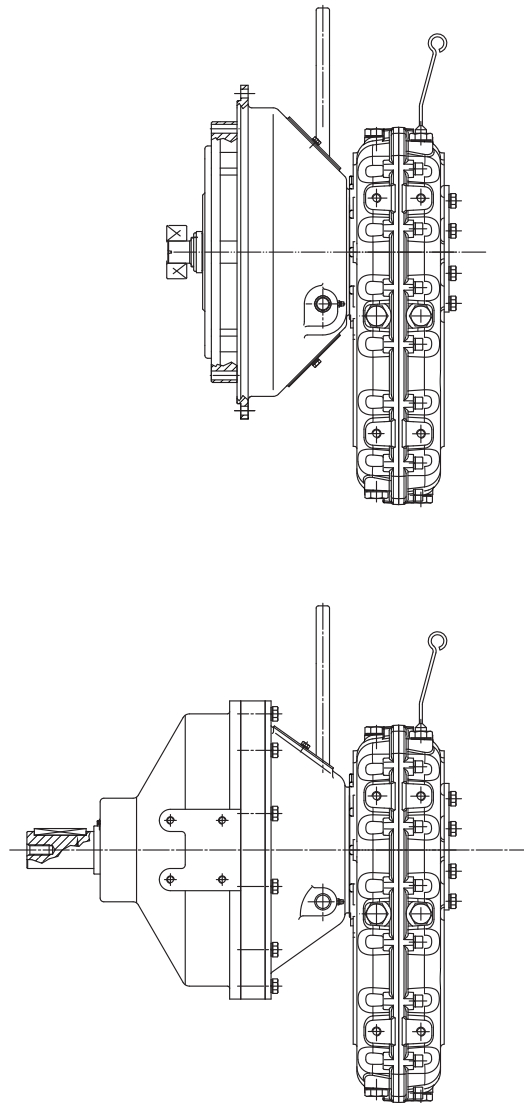

INDEPENDENT MOUNT
WITH ONE PLATE 10" CLUTCH
AM 110 BDS 130

INDEPENDENT MOUNT
WITH ONE PLATE 11" CLUTCH
AM 110 BDS 145

INDEPENDENT MOUNT
WITH TWO PLATE 11" CLUTCH
AM 110 BDS 290

AM 110 TECHNICAL DATA

RATIO :1	MAX. INPUT TORQUE N-m (lbf-ft)	MAX. OUTPUT TORQUE PER PUMP PAD N-m (lbf-ft)	MAX. INPUT SPEED RPM	OIL QUANTITY L (gal)
0.49	735 (542)	407 (300)	2400	2.3 (0.61)
0.58	705 (520)	465 (343)	2500	2.1 (0.55)
0.67	675 (499)	515 (380)	2650	1.9 (0.50)
0.77	635 (468)	579 (427)	2850	1.8 (0.46)
1.00	540 (398)	692 (510)	3200	1.6 (0.42)
1.30	490 (361)	753 (555)	3600	1.3 (0.34)
1.50	450 (332)	766 (565)	3950	1.1 (0.29)

AM 110 MOMENT OF INERTIA DATA

RATIO :1	B kg-m ² (lb-ft ²)	BD 130 kg-m ² (lb-ft ²)	BD 145 kg-m ² (lb-ft ²)	BD 290 kg-m ² (lb-ft ²)	BDS 130 kg-m ² (lb-ft ²)	BDS 145 kg-m ² (lb-ft ²)	BDS 290 kg-m ² (lb-ft ²)
0.49	0.0825 (1.96)	0.2200 (5.22)	0.345 (8.18)	0.532 (12.63)	0.332 (7.89)	0.520 (12.34)	0.757 (17.97)
0.58	0.0717 (1.70)	0.2092 (4.96)	0.334 (7.93)	0.522 (12.38)	0.322 (7.63)	0.509 (12.08)	0.747 (17.72)
0.67	0.0642 (1.52)	0.2017 (4.79)	0.327 (7.75)	0.514 (12.20)	0.314 (7.45)	0.502 (11.90)	0.739 (17.54)
0.77	0.0544 (1.29)	0.1919 (4.55)	0.317 (7.52)	0.504 (11.97)	0.304 (7.22)	0.492 (11.67)	0.729 (17.31)
1.00	0.0405 (0.96)	0.1780 (4.22)	0.303 (7.19)	0.490 (11.64)	0.290 (6.89)	0.478 (11.34)	0.715 (16.98)
1.30	0.0325 (0.77)	0.1700 (4.03)	0.295 (7.00)	0.482 (11.45)	0.282 (6.70)	0.470 (11.15)	0.707 (16.79)
1.50	0.0290 (0.69)	0.1665 (3.95)	0.291 (6.92)	0.479 (11.36)	0.279 (6.62)	0.466 (11.07)	0.704 (16.70)

MODEL	WEIGHT kg (lb)
AM 110 B	50 (110)
AM 110 BD 130	90 (198)
AM 110 BD 145	94 (207)
AM 110 BD 290	116 (256)
AM 110 BDS 130	121 (267)
AM 110 BDS 145	125 (276)
AM 110 BDS 290	143 (315)

Maximum torque and maximum speed may be limited by clutch option. Refer to Option Selection on page 14 for clutch limitations. Refer to pages 14-15 for input Option Selection.

AM 216 MAXIMUM INPUT POWER 220 kW (295 hp)

**BASIC PUMP DRIVE
AM 216 B**

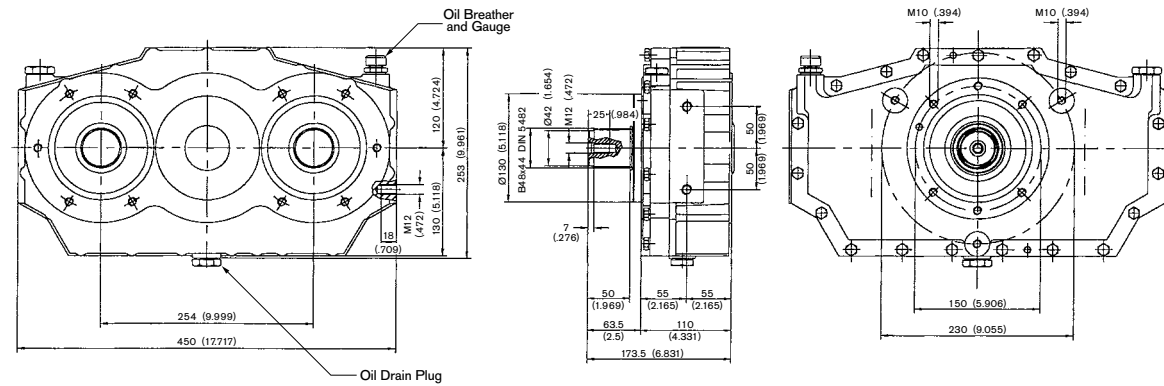

**WITH ONE PLATE 10"
CLUTCH
AM 216 BD 130**

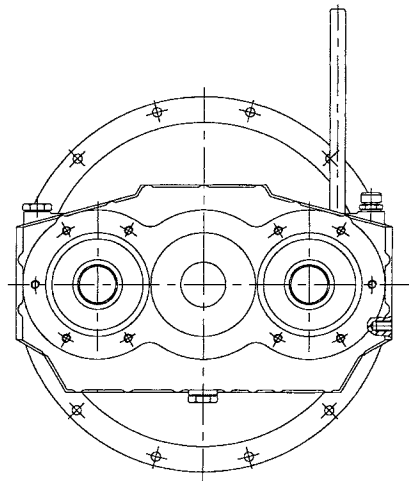

**WITH ONE PLATE 11" CLUTCH
AM 216 BD 145**

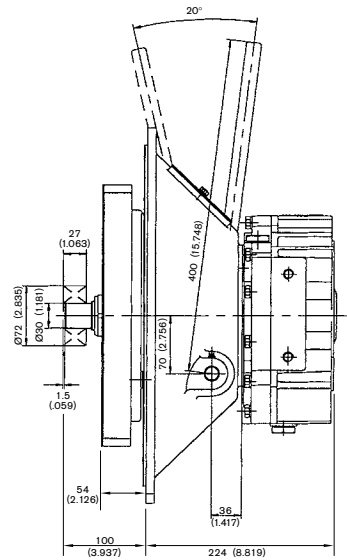

**INDEPENDENT MOUNT
WITH ONE PLATE 10"
CLUTCH
AM 216 BDS 130**

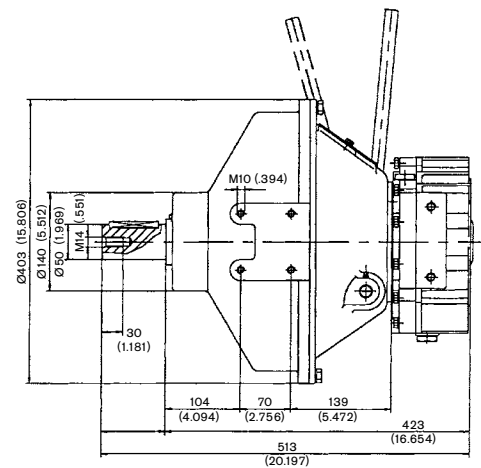

**INDEPENDENT MOUNT
WITH ONE PLATE 11" CLUTCH
AM 216 BDS 145**

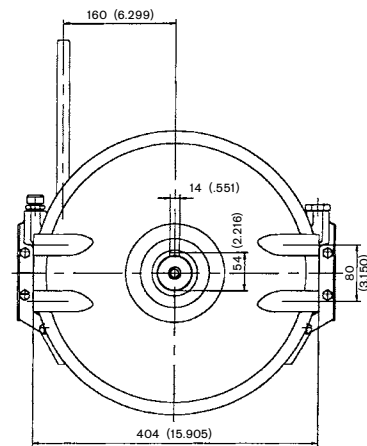

AM 216 TECHNICAL DATA

RATIO :1	MAX. INPUT TORQUE N-m (lbf-ft)	MAX. OUTPUT TORQUE PER PUMP PAD N-m (lbf-ft)	MAX. INPUT SPEED RPM	MAX. OUTPUT SPEED RPM	OIL QUANTITY L (gal)
0.50	800 (590)	251 (185)	2400	4800	1.9 (0.50)
0.68	766 (565)	323 (238)	3650	3897	2.0 (0.53)
0.79	735 (542)	364 (268)	2850	3608	2.0 (0.53)
1.00	658 (485)	427 (315)	3200	3200	1.7 (0.45)
1.27	564 (416)	475 (350)	3600	2835	1.5 (0.40)
1.47	500 (369)	488 (360)	3950	2687	1.3 (0.34)

AM 216 MOMENT OF INERTIA DATA

RATIO :1	B kg-m ² (lb-ft ²)	BD 130 kg-m ² (lb-ft ²)	BD 145 kg-m ² (lb-ft ²)	BDS 130 kg-m ² (lb-ft ²)	BDS 145 kg-m ² (lb-ft ²)
0.50					
0.68	0.0278 (0.66)	0.1653 (3.92)	0.2903 (6.89)	0.2778 (6.59)	0.4653 (11.04)
0.79	0.0248 (0.59)	0.1622 (3.85)	0.2873 (6.82)	0.2748 (6.52)	0.4623 (10.97)
1.00	0.0205 (0.49)	0.1580 (3.75)	0.2830 (6.72)	0.2705 (6.42)	0.4580 (10.87)
1.27	0.0167 (0.40)	0.1542 (3.66)	0.2792 (6.63)	0.2667 (6.33)	0.4542 (10.78)
1.47	0.0151 (0.36)	0.1526 (3.62)	0.2776 (6.59)	0.2651 (6.29)	0.4526 (10.74)

MODEL	WEIGHT kg (lb)
AM 216 B	36 (79)
AM 216 BD 130	76 (168)
AM 216 BD 145	80 (176)
AM 216 BDS 130	107 (236)
AM 216 BDS 145	111 (245)

Maximum torque and maximum speed may be limited by clutch option. Refer to Option Selection on page 14 for clutch limitations. Refer to pages 14-15 for input Option Selection.

AM 320 MAXIMUM INPUT POWER 215 kW (285 hp)

**BASIC PUMP DRIVE
AM 320 B**

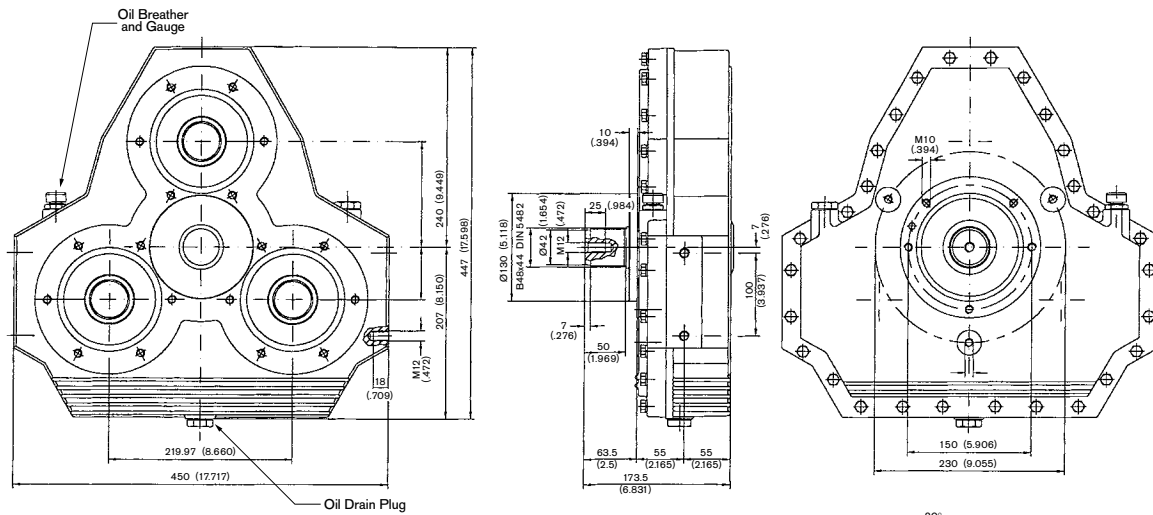

**WITH ONE PLATE 10"
CLUTCH
AM 320 BD 130**

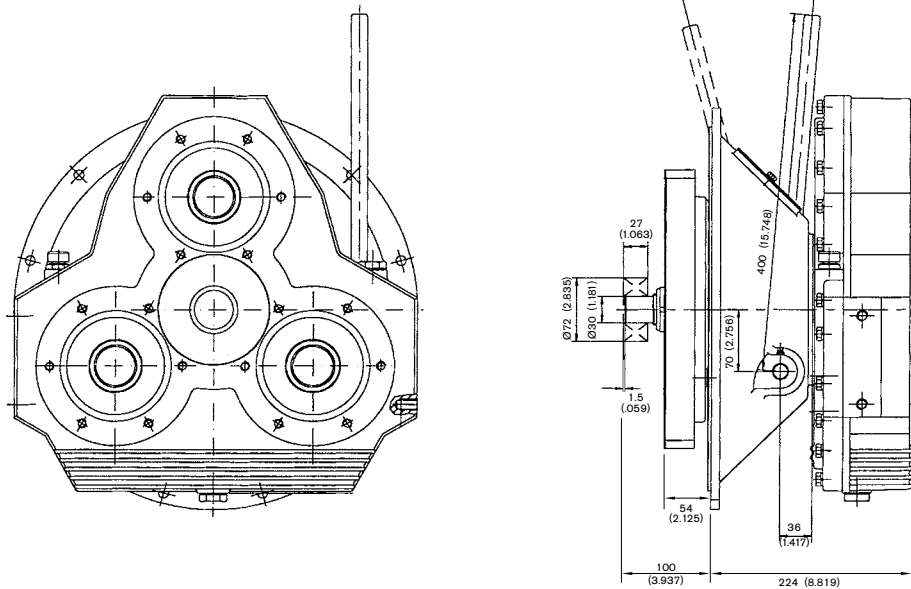

**WITH ONE PLATE 11" CLUTCH
AM 320 BD 145**

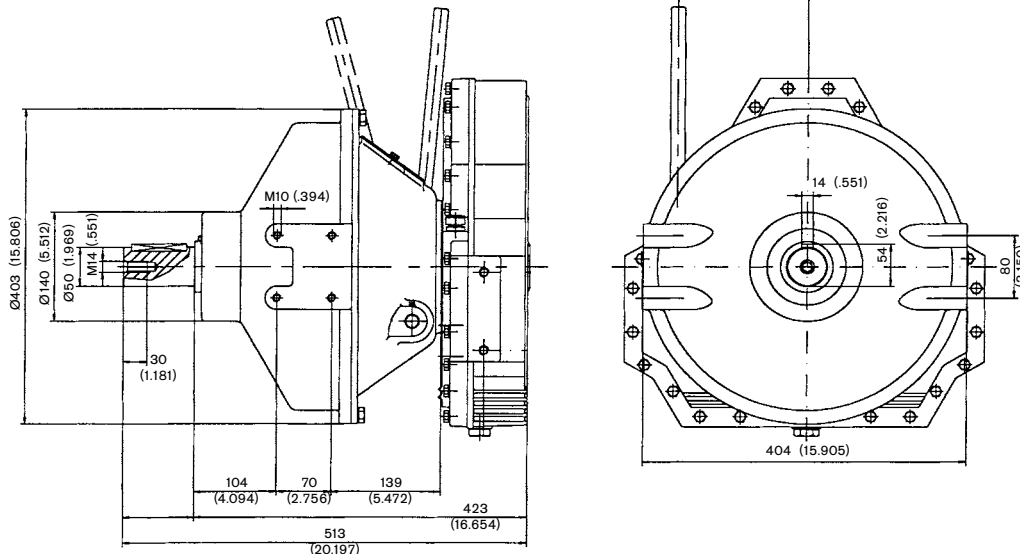

**INDEPENDENT MOUNT
WITH ONE PLATE 10"
CLUTCH
AM 320 BDS 130**

**INDEPENDENT MOUNT
WITH ONE PLATE 11" CLUTCH
AM 320 BDS 145**

AM 320 TECHNICAL DATA

RATIO :1	MAX. INPUT TORQUE N-m (lbf-ft)	MAX. OUTPUT TORQUE PER PUMP PAD N-m (lbf-ft)	MAX. INPUT SPEED RPM	MAX. OUTPUT SPEED RPM	OIL QUANTITY L (gal)
0.68	709 (523)	323 (238)	2650	3897	3.1 (0.82)
0.79	688 (507)	364 (268)	2850	3608	2.4 (0.63)
1.00	635 (468)	427 (315)	3200	3200	2.2 (0.58)
1.27	544 (401)	475 (350)	3600	2835	2.0 (0.53)
1.47	477 (352)	488 (360)	3950	2687	1.8 (0.48)

AM 320 MOMENT OF INERTIA DATA

RATIO :1	B kg-m ² (lb-ft ²)	BD 130 kg-m ² (lb-ft ²)	BD 145 kg-m ² (lb-ft ²)	BDS 130 kg-m ² (lb-ft ²)	BDS 145 kg-m ² (lb-ft ²)
0.68	0.0344 (0.82)	0.1719 (4.08)	0.297 (7.05)	0.284 (6.75)	0.472 (11.20)
0.79	0.0312 (0.74)	0.1688 (4.01)	0.294 (6.97)	0.281 (6.67)	0.469 (11.12)
1.00	0.0271 (0.64)	0.1646 (3.91)	0.290 (6.87)	0.277 (6.58)	0.465 (11.03)
1.27	0.0226 (0.54)	0.1601 (3.80)	0.285 (6.77)	0.273 (6.47)	0.460 (10.92)
1.47	0.0206 (0.49)	0.1581 (3.75)	0.283 (6.72)	0.271 (6.42)	0.4582 (10.87)

MODEL	WEIGHT kg (lb)
AM 320 B	42 (93)
AM 320 BD 130	82 (181)
AM 320 BD 145	86 (190)
AM 320 BDS 130	113 (249)
AM 320 BDS 145	117 (258)

Maximum torque and maximum speed may be limited by clutch option. Refer to Option Selection on page 14 for clutch limitations. Refer to pages 14-15 for input Option Selection.

AM 220 MAXIMUM INPUT POWER 430 kW (580 hp)

**BASIC PUMP DRIVE
AM 220 B**

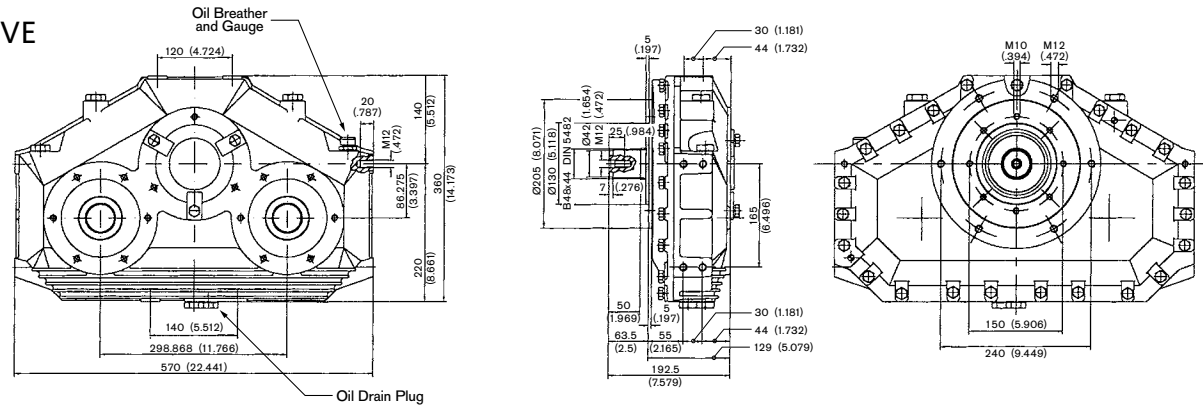

MODEL	A
AM 220 BD 130 & 145	243 (9.567)
AM 220 BD 290	276 (10.866)

**WITH ONE PLATE 10" CLUTCH
AM 220 BD 130**

**WITH ONE PLATE 11" CLUTCH
AM 220 BD 145**

**WITH TWO PLATE 11" CLUTCH
AM 220 BD 290**

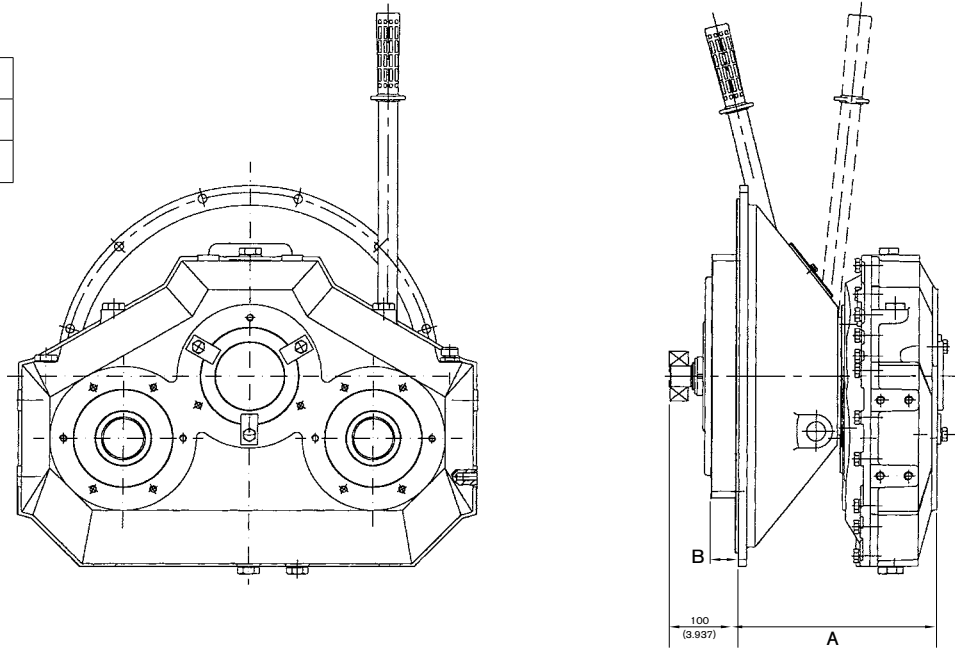

**INDEPENDENT MOUNT
WITH ONE PLATE 10" CLUTCH
AM 220 BDS 130**

**INDEPENDENT MOUNT
WITH ONE PLATE 11" CLUTCH
AM 220 BDS 145**

**INDEPENDENT MOUNT
WITH TWO PLATE 11" CLUTCH
AM 220 BDS 290**

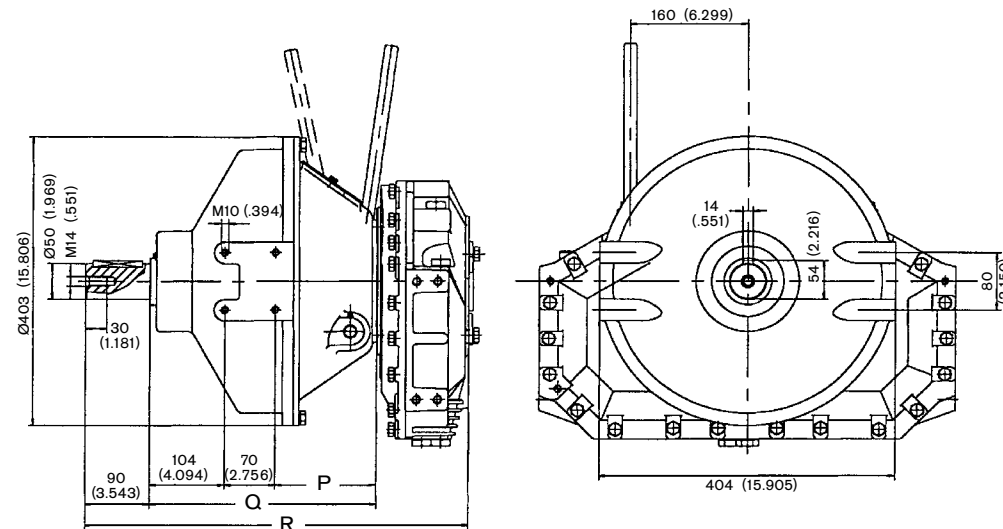

AM 220 TECHNICAL DATA

RATIO :1	MAX. INPUT TORQUE N-m (lbf-ft)	MAX. OUTPUT TORQUE PER PUMP PAD N-m (lbf-ft)	MAX. INPUT SPEED RPM	MAX. OUTPUT SPEED RPM	OIL QUANTITY L (gal)
0.49	1424 (1050)	407 (300)	2400	4898	2.5 (0.66)
0.58	1419 (1046)	465 (343)	2500	4310	2.0 (0.53)
0.67	1383 (1020)	515 (380)	2650	3955	1.8 (0.48)
0.77	1325 (977)	579 (427)	2850	3701	1.8 (0.48)
1.00	1289 (950)	692 (510)	3200	3200	1.4 (0.37)
1.30	990 (730)	753 (555)	3600	2769	1.4 (0.37)
1.50	882 (650)	766 (565)	3950	2633	1.2 (0.32)

AM 220 MOMENT OF INERTIA DATA

RATIO :1	B kg-m ² (lb-ft ²)	BD 130 kg-m ² (lb-ft ²)	BD 145 kg-m ² (lb-ft ²)	BD 290 kg-m ² (lb-ft ²)	BDS 130 kg-m ² (lb-ft ²)	BDS 145 kg-m ² (lb-ft ²)	BDS 290 kg-m ² (lb-ft ²)
0.49							
0.58							
0.67	0.0952 (2.26)	0.2327 (5.52)	0.358 (8.49)	0.545 (12.94)	0.345 (8.19)	0.533 (12.64)	0.770 (18.28)
0.77	0.0839 (1.99)	0.2214 (5.25)	0.346 (8.22)	0.540 (12.67)	0.334 (7.92)	0.521 (12.37)	0.759 (18.01)
1.00	0.0561 (1.33)	0.1936 (4.59)	0.319 (7.56)	0.506 (12.01)	0.306 (7.26)	0.494 (11.71)	0.731 (17.35)
1.30	0.0503 (1.19)	0.1878 (4.46)	0.313 (7.42)	0.500 (11.87)	0.300 (7.13)	0.488 (11.58)	0.725 (17.21)
1.50	0.0476 (1.13)	0.1851 (4.39)	0.310 (7.36)	0.498 (11.81)	0.298 (7.06)	0.485 (11.51)	0.723 (17.15)

MODEL	WEIGHT kg (lb)
AM 220 B	70 (154)
AM 220 BD 130	110 (243)
AM 220 BD 145	114 (251)
AM 220 BD 290	136 (300)
AM 220 BDS 130	141 (311)
AM 220 BDS 145	145 (320)
AM 220 BDS 290	163 (359)

Maximum torque and maximum speed may be limited by clutch option. Refer to Option Selection on page 14 for clutch limitations. Refer to pages 14-15 for input Option Selection.

AM 330 MAXIMUM INPUT POWER 375 kW (500 hp)

BASIC PUMP DRIVE AM 330 B

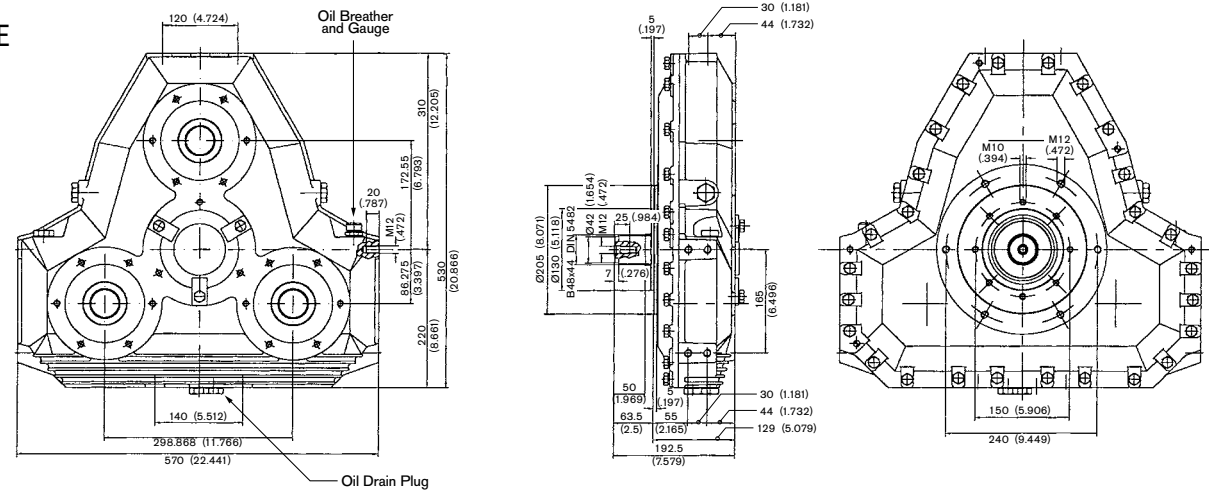

MODEL	A
AM 330 BD 130 & 145	243 (9.567)
AM 330 BD 290	276 (10.866)

WITH ONE PLATE 10" CLUTCH AM 330 BD 130

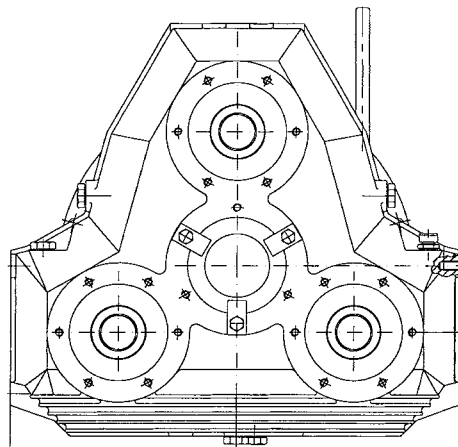

WITH ONE PLATE 11" CLUTCH AM 330 BD 145

WITH TWO PLATE 11" CLUTCH AM 330 BD 290

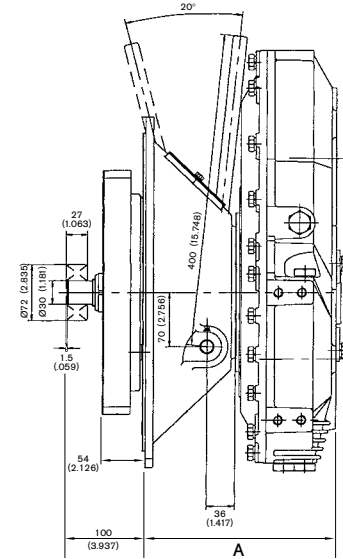

INDEPENDENT MOUNT WITH ONE PLATE 10" CLUTCH AM 330 BDS 130

INDEPENDENT MOUNT WITH ONE PLATE 11" CLUTCH AM 330 BDS 145

INDEPENDENT MOUNT WITH ONE PLATE 11" CLUTCH AM 330 BDS 290

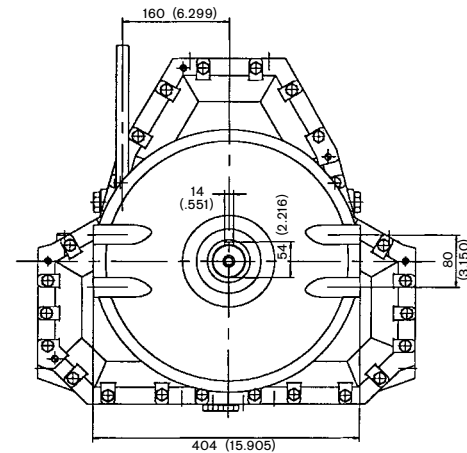
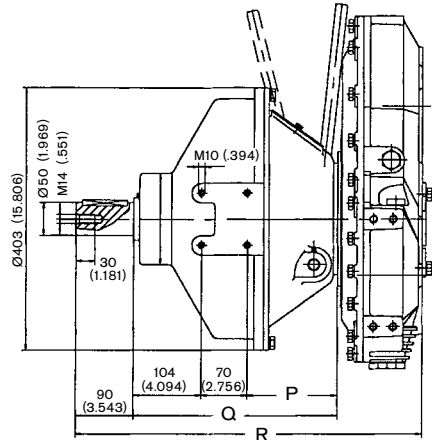

AM 330 TECHNICAL DATA

RATIO	MAX. INPUT TORQUE N-m (lbf-ft)	MAX. OUTPUT TORQUE PER PUMP PAD N-m (lbf-ft)	MAX. INPUT SPEED RPM	MAX. OUTPUT SPEED RPM	OIL QUANTITY L (gal)
:1					
0.49	1371 (1011)	407 (300)	2400	4898	2.5 (0.66)
0.58	1362 (1004)	465 (343)	2500	4310	2.0 (0.53)
0.67	1329 (980)	515 (380)	2650	3955	1.8 (0.48)
0.77	1272 (938)	579 (427)	2850	3701	1.8 (0.48)
1.00	1112 (820)	692 (510)	3200	3200	1.4 (0.37)
1.30	956 (705)	753 (555)	3600	2769	1.4 (0.37)
1.50	849 (626)	766 (565)	3950	2633	1.2 (0.32)

AM 330 MOMENT OF INERTIA DATA

RATIO	B	BD 130	BD 145	BD 290	BDS 130	BDS 145	BDS 290
:1	kg-m ² (lb-ft ²)	kg-m ² (lb-ft ²)	kg-m ² (lb-ft ²)	kg-m ² (lb-ft ²)	kg-m ² (lb-ft ²)	kg-m ² (lb-ft ²)	kg-m ² (lb-ft ²)
0.49							
0.58							
0.67	0.1231 (2.92)	0.2606 (6.18)	0.386 (9.15)	0.573 (13.60)	0.373 (8.85)	0.561 (13.30)	0.798 (18.94)
0.77	0.1114 (2.64)	0.2489 (5.91)	0.374 (8.87)	0.561 (13.32)	0.361 (8.58)	0.549 (13.03)	0.786 (18.66)
1.00	0.0744 (1.77)	0.2119 (5.03)	0.337 (7.99)	0.524 (12.44)	0.324 (7.70)	0.520 (12.15)	0.749 (17.78)
1.30	0.0668 (1.59)	0.2043 (4.85)	0.329 (7.81)	0.517 (12.26)	0.317 (7.52)	0.504 (11.97)	0.742 (17.60)
1.50	0.0646 (1.53)	0.2022 (4.80)	0.327 (7.76)	0.515 (12.21)	0.315 (7.47)	0.502 (11.92)	0.740 (17.55)

MODEL	WEIGHT kg (lb)
AM 330 B	130 (287)
AM 330 BD 130	143 (315)
AM 330 BD 145	147 (324)
AM 330 BD 290	169 (373)
AM 330 BDS 130	174 (384)
AM 330 BDS 145	178 (392)
AM 330 BDS 290	196 (432)

Maximum torque and maximum speed may be limited by clutch option. Refer to Option Selection on page 14 for clutch limitations. Refer to pages 14-15 for input Option Selection.

OPTION SELECTION AM 216-320-220-330

INPUT CONFIGURATIONS

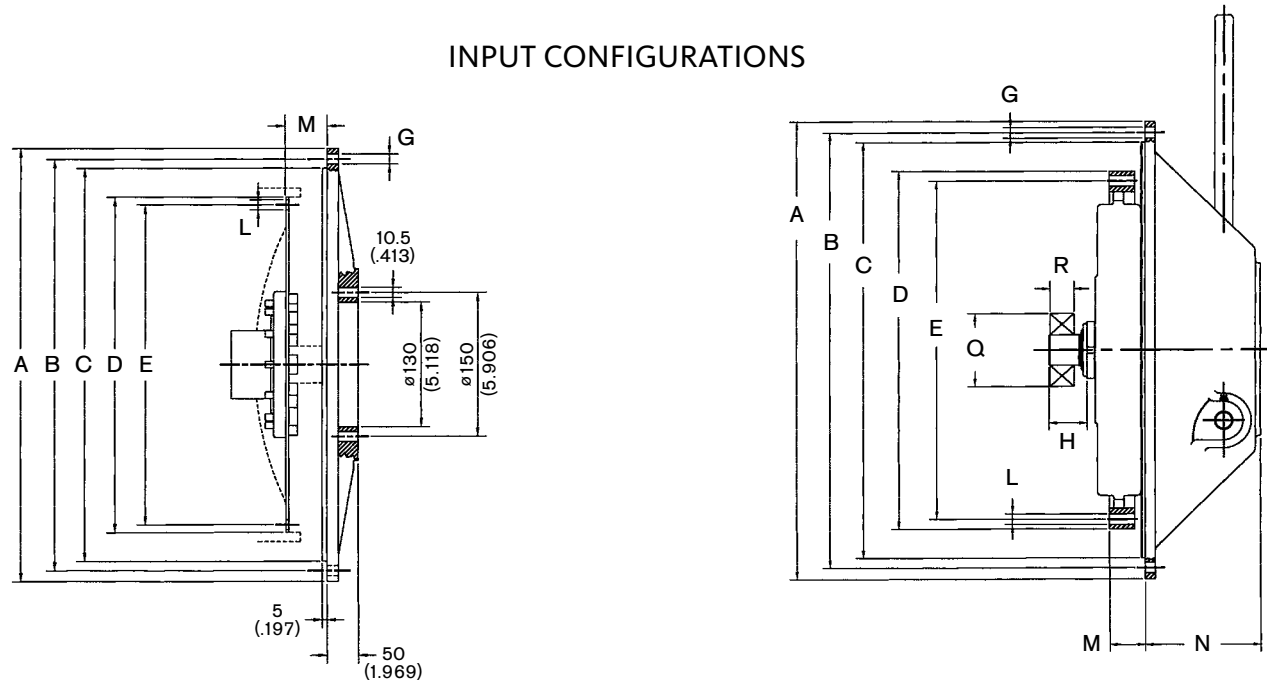

DIMENSIONS				
mm (in)	SAE 1	SAE 2	SAE 3	SAE 4
A	552.00 (21.7332)	489.00 (19.252)	451.00 (17.7559)	403.22 (15.8748)
B	530.22 (20.875)	466.72 (18.375)	428.62 (16.875)	381.00 (15.000)
C	511.17 (20.125)	447.67 (17.625)	409.57 (16.125)	361.95 (14.250)
G	12.00 (0.472)	11.00 (0.433)	11.00 (0.433)	11.00 (0.433)
NUMBER OF HOLES	12	12	12	12

mm (in)	BD 130	BD 145	BD 290
D	314.32 (12.375)	352.42 (13.875)	352.42 (13.875)
E	295.27 (11.625)	333.37 (13.125)	333.37 (13.125)
H	37 (1.457)	37 (1.457)	37 (1.457)
L	10.5 (0.413)	10.5 (0.413)	10.5 (0.413)
NUMBER OF HOLES	8	8	8
M	54 (2.126)	39.70 (1.563)	39.70 (1.563)
N	114 (4.488)	114 (4.488)	147 (5.787)

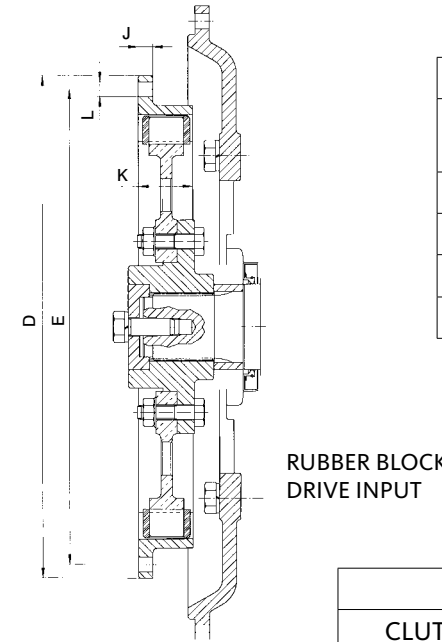

RUBBER BLOCK DRIVE MAX. TORQUE RATING		
FLYWHEEL	CONTINUOUS N-m (lbf-ft)	INTERMEDIATE N-m (lbf-ft)
8"	170 (125)	220 (162)
10"	310 (229)	400 (295)
11.5"	480 (354)	620 (457)
14"	940 (693)	1210 (892)

CLUTCH OPTIONS			
CLUTCH MODEL	SAE HOUSING	MAX. INPUT TORQUE N-m (lbf-ft)	MAX. INPUT SPEED
BD 130	3-4	330 (242)	3100
BD 145	3-4	450 (332)	3100
BD 290	1-2-3	880 (649)	2900

DIMENSIONS						
FLYWHEEL	D mm (in)	E mm (in)	J mm (in)	K mm (in)	L mm (in)	NUMBER OF HOLES
8"	263.52 (10.375)	244.47 (9.625)	9.00 (0.354)	34.00 (1.339)	10.30 (0.406)	6
10"	314.32 (12.375)	299.27 (11.625)	10.00 (0.394)	34.00 (1.339)	10.30 (0.406)	8
11.5"	352.42 (13.875)	333.37 (13.125)	10.00 (0.394)	38.00 (1.496)	10.30 (0.406)	8
14"	466.72 (18.375)	435.15 (17.246)	41.00 (1.614)	41.00 (1.614)	13.50 (0.531)	8

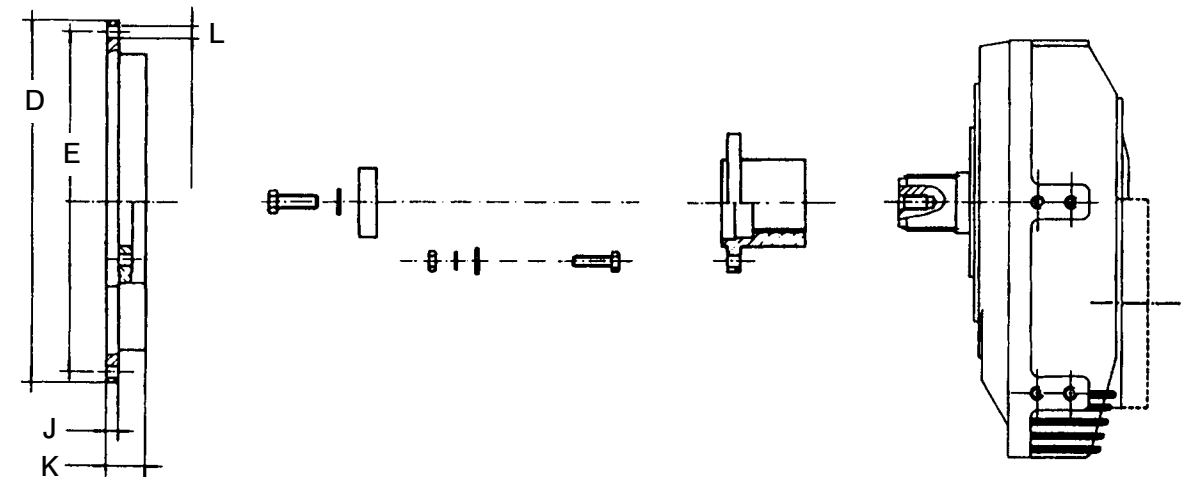

AM 230 MAXIMUM INPUT POWER 495 kW (660 hp)

BASIC PUMP DRIVE AM 230 B

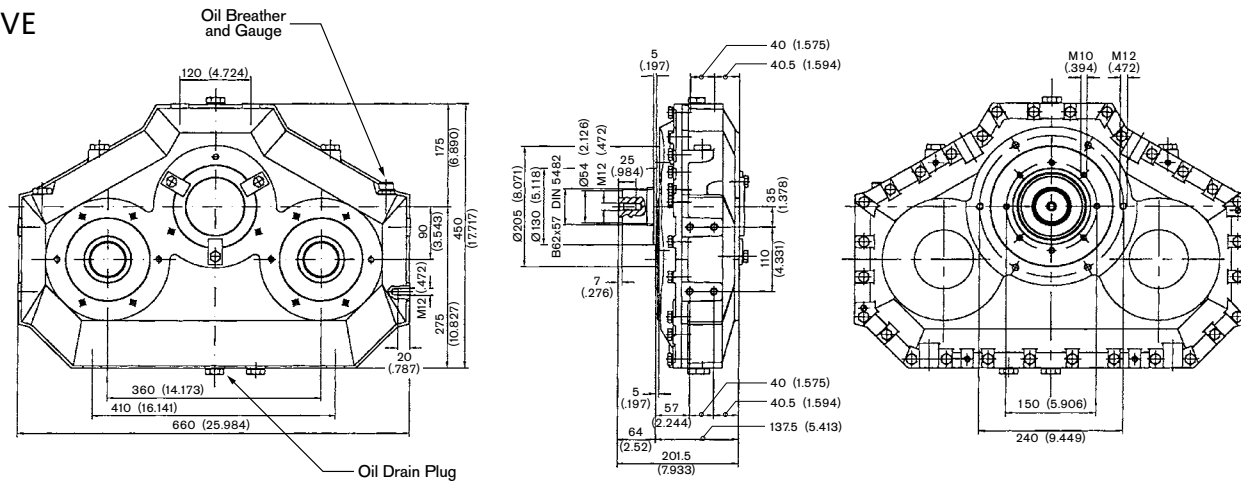

MODEL	A	B
AM 230 BD 290	284.5 (11.20)	39.7 (1.563)
AM 230 BD 2200	373.5 (14.70)	25.4 (1.000)
AM 230 BD 3300	401.5 (15.81)	25.4 (1.000)

WITH TWO PLATE 11" CLUTCH AM 230 BD 290

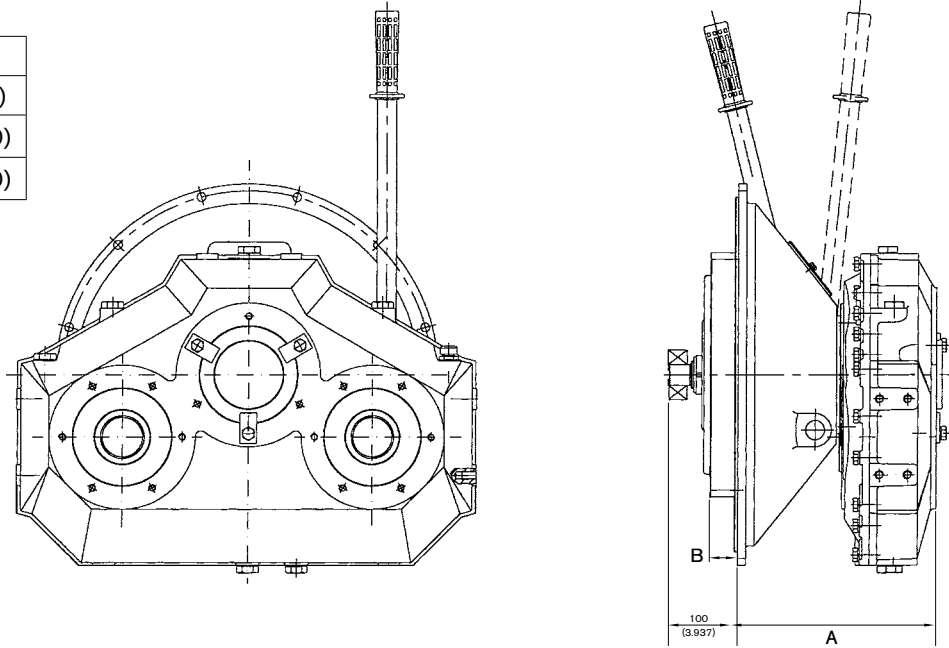

WITH TWO PLATE 14" CLUTCH AM 230 BD 2200

WITH THREE PLATE 14" CLUTCH AM 230 BD 3300

INDEPENDENT MOUNT WITH TWO PLATE 11" CLUTCH AM 230 BDS 290

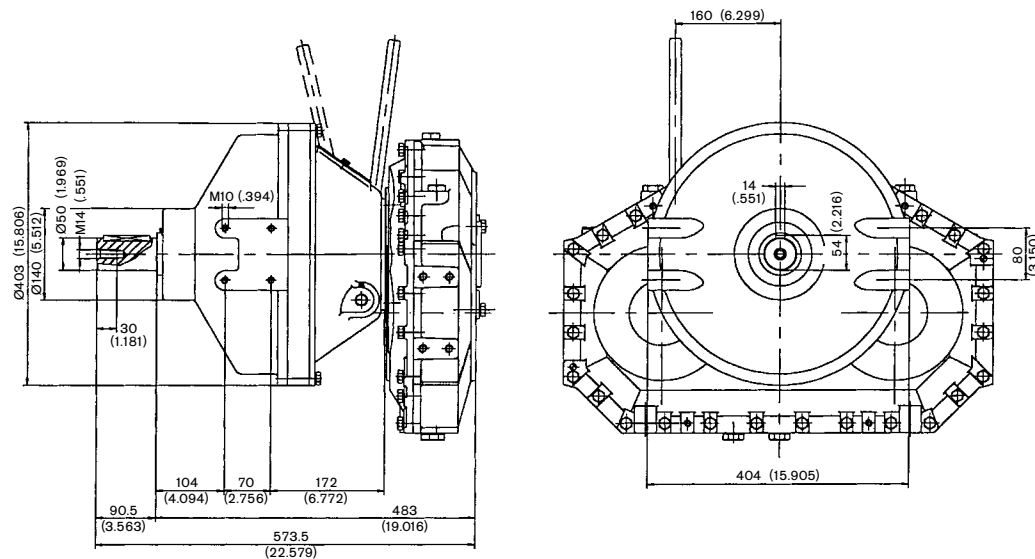

AM 230 TECHNICAL DATA

RATIO :1	MAX. INPUT TORQUE N-m (lbf-ft)	MAX. OUTPUT TORQUE PER PUMP PAD N-m (lbf-ft)	MAX. INPUT SPEED RPM	MAX. OUTPUT SPEED RPM	OIL QUANTITY L (gal)
0.50	2204 (1625)	563 (415)	1950	3900	5.5 (1.45)
0.58	2184 (1610)	651 (480)	2050	3534	5.0 (1.32)
0.67	2102 (1550)	705 (520)	2200	3284	4.5 (1.19)
0.76	2035 (1500)	800 (590)	2300	3026	4.0 (1.06)
1.00	1808 (1333)	997 (735)	2600	2600	3.7 (0.98)
1.31	1763 (1300)	1065 (785)	3000	2290	3.2 (0.85)
1.48	1628 (1200)	1092 (805)	3200	2162	3.0 (0.79)

AM 230 MOMENT OF INERTIA DATA

RATIO :1	B kg-m ² (lb-ft ²)	BD 290 kg-m ² (lb-ft ²)	BD 2200 kg-m ² (lb-ft ²)	BD 3300 kg-m ² (lb-ft ²)	BDS 290 kg-m ² (lb-ft ²)	BDS 2200 kg-m ² (lb-ft ²)
0.51						
0.58						
0.67	0.2099 (4.98)	0.660 (15.66)	2.035 (48.29)	2.760 (65.49)	0.885 (21.00)	3.210 (76.17)
0.76	0.1840 (4.37)	0.634 (15.04)	2.009 (47.67)	2.734 (64.88)	0.859 (20.38)	3.184 (75.56)
1.00	0.1191 (2.83)	0.569 (13.50)	1.944 (46.13)	2.669 (63.34)	0.794 (18.84)	3.119 (74.02)
1.31	0.1082 (2.57)	0.558 (13.25)	1.933 (45.88)	2.658 (63.08)	0.783 (18.59)	3.108 (73.76)
1.48	0.1036 (2.46)	0.554 (13.14)	1.929 (45.77)	2.654 (62.97)	0.779 (18.48)	3.104 (73.65)

MODEL	WEIGHT kg (lb)
AM 230 B	94 (207)
AM 230 BD 290	160 (352)
AM 230 BD 2200	227 (499)
AM 230 BD 3300	270 (594)
AM 230 BDS 290	187 (411)
AM 230 BDS 2200	337 (741)

INDEPENDENT MOUNT WITH TWO PLATE 14" CLUTCH AM 230 BDS 2200

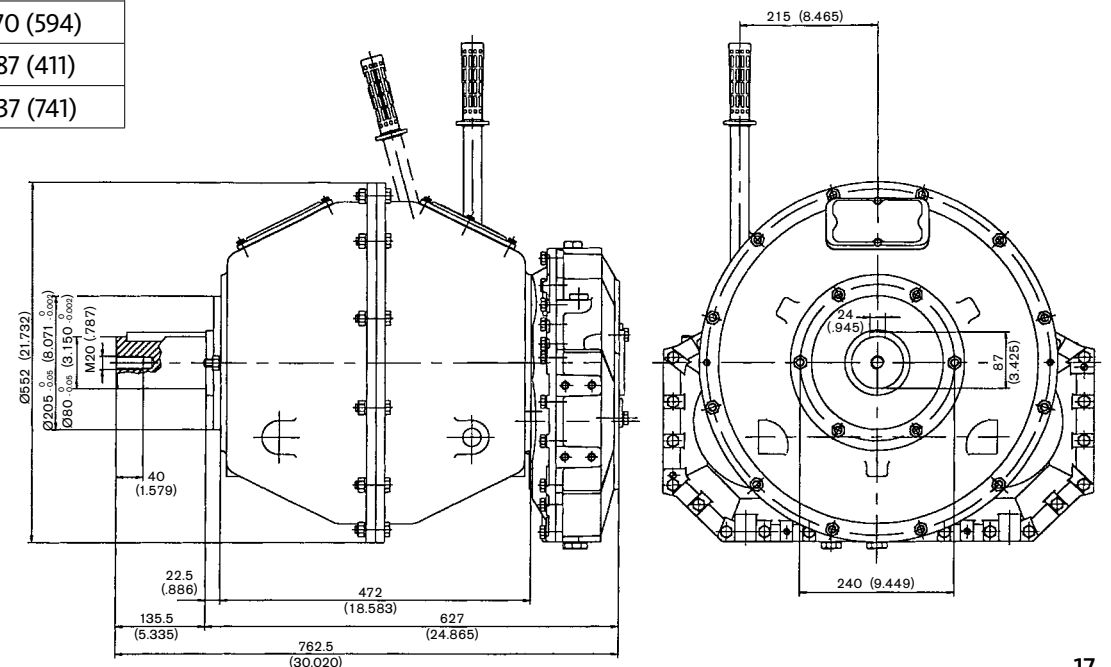

AM 232 MAXIMUM INPUT POWER 570 kW (765 hp)

BASIC PUMP DRIVE AM 232 B

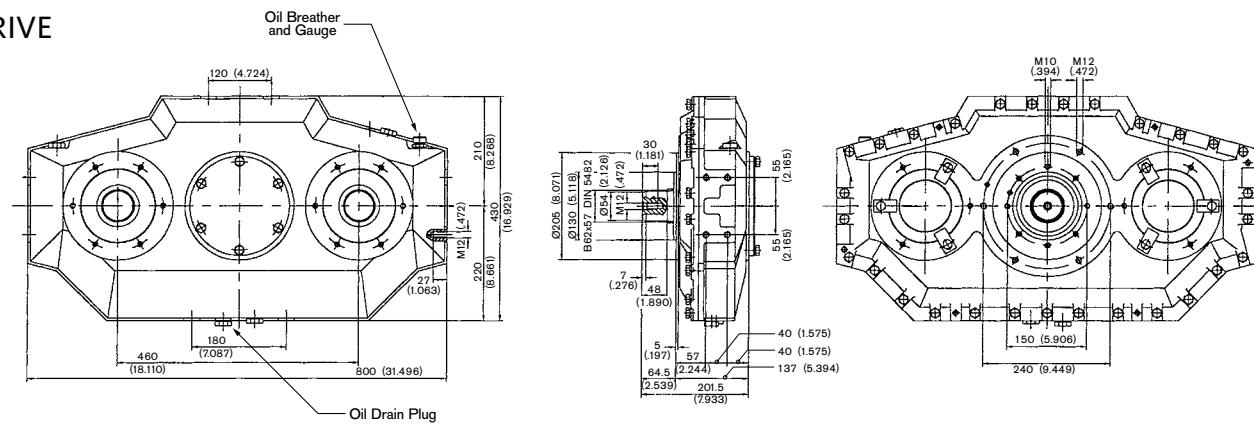

Two additional pump pads available on input side of drive.

MODEL	A	B
AM 232 BD 290	284 (11.18)	39.7 (1.563)
AM 232 BD 2200	373 (14.69)	25.4 (1.000)
AM 232 BD 3300	401 (15.79)	25.4 (1.000)

WITH TWO PLATE 11" CLUTCH AM 232 BD 290

WITH TWO PLATE 14" CLUTCH AM 232 BD 2200

WITH THREE PLATE 14" CLUTCH AM 232 BD 3300

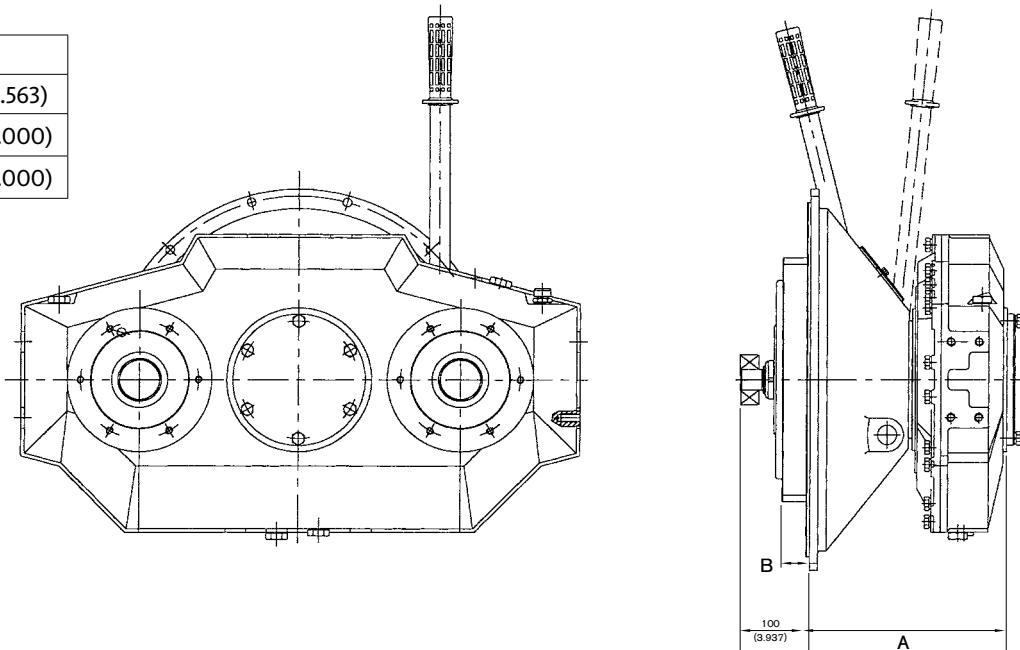

INDEPENDENT MOUNT WITH TWO PLATE 11" CLUTCH AM 232 BDS 290

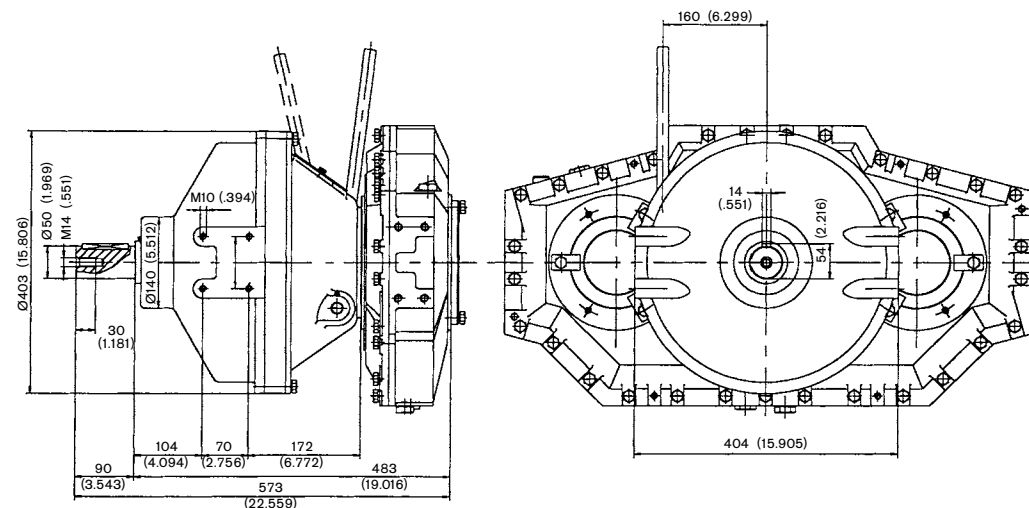

AM 232 TECHNICAL DATA

RATIO	MAX. INPUT TORQUE N-m (lbf-ft)	MAX. OUTPUT TORQUE PER PUMP PAD* N-m (lbf-ft)	MAX. INPUT SPEED RPM	MAX. OUTPUT SPEED RPM	OIL QUANTITY L (gal)
:1					
0.49	2611 (1925)	651 (480)	1750	3571	5.0 (1.32)
0.77	2441 (1800)	943 (695)	2100	2727	5.0 (1.32)
1.00	2279 (1680)	1153 (850)	2400	2400	4.5 (1.19)

AM 232 MOMENT OF INERTIA DATA

RATIO	B	BD 290	BD 2200	BD 3300	BDS 290	BDS 2200
:1	kg-m ² (lb-ft ²)	kg-m ² (lb-ft ²)	kg-m ² (lb-ft ²)	kg-m ² (lb-ft ²)	kg-m ² (lb-ft ²)	kg-m ² (lb-ft ²)
0.49	0.3184 (7.56)	0.768 (18.23)	2.143 (50.86)	2.868 (68.07)	0.993 (23.57)	3.318 (78.75)
0.77	0.2292 (5.44)	0.679 (16.12)	2.054 (48.75)	2.794 (66.29)	0.904 (21.46)	3.229 (76.63)
1.00	0.2026 (4.81)	0.653 (15.49)	2.028 (48.12)	2.753 (65.32)	0.878 (20.83)	3.203 (76.00)

MODEL	WEIGHT kg (lb)
AM 232 B	126 (278)
AM 232 BD 290	192 (423)
AM 232 BD 2200	259 (571)
AM 232 BD 3300	302 (666)
AM 232 BDS 290	219 (483)
AM 232 BDS 2200	369 (814)

INDEPENDENT MOUNT WITH TWO PLATE 14" CLUTCH AM 232 BDS 2200

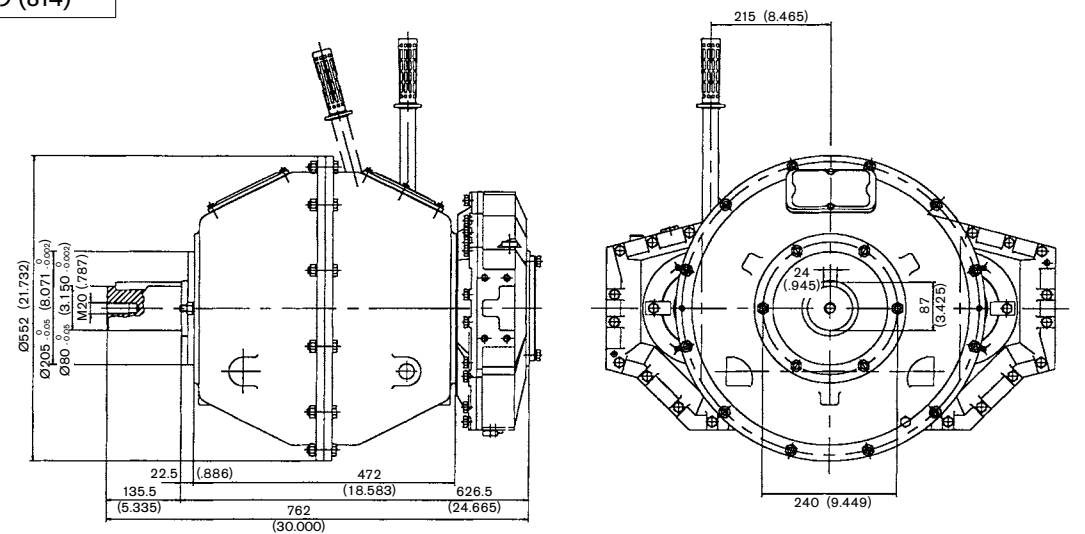

* Maximum output power and torque ratings are based on two pump pads.

Maximum torque and maximum speed may be limited by clutch option. Refer to Option Selection on page 24 for clutch limitations. Refer to pages 24-25 for input and Option Selection.

AM 345 MAXIMUM INPUT POWER 755 kW (1010 hp)

**BASIC PUMP DRIVE
AM 345 B**

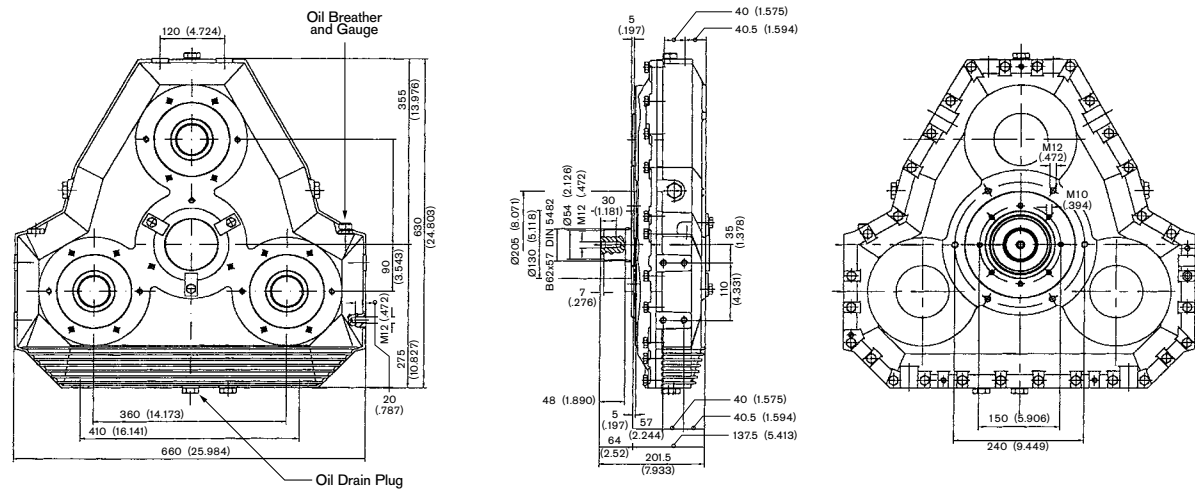

MODEL	A	B
AM 345 BD 290	284.5 (11.20)	39.7 (1.563)
AM 345 BD 2200	373.5 (14.70)	25.4 (1.000)
AM 345 BD 3300	401.5 (15.81)	25.4 (1.000)

**WITH TWO PLATE 11" CLUTCH
AM 345 BD 290**

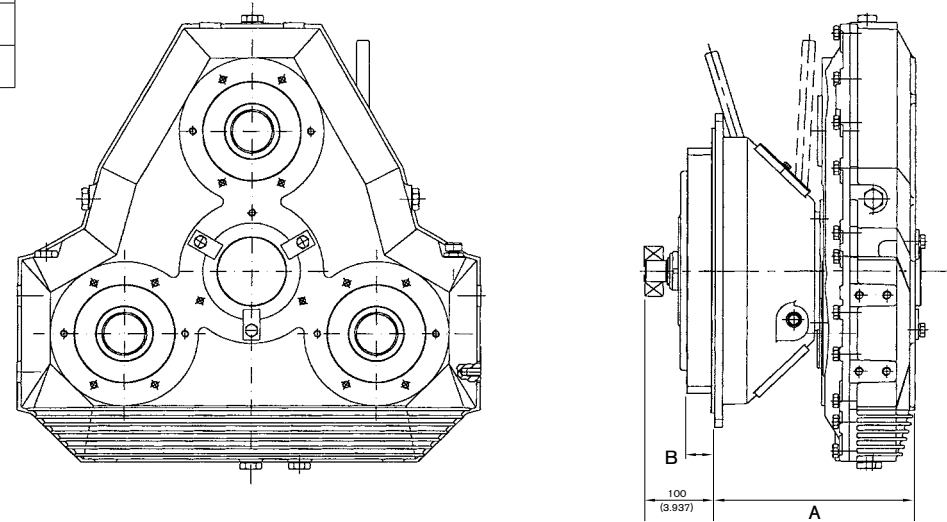

**WITH TWO PLATE 14" CLUTCH
AM 345 BD 2200**

**WITH THREE PLATE 14" CLUTCH
AM 345 BD 3300**

**INDEPENDENT MOUNT
WITH TWO PLATE 11" CLUTCH
AM 345 BDS 290**

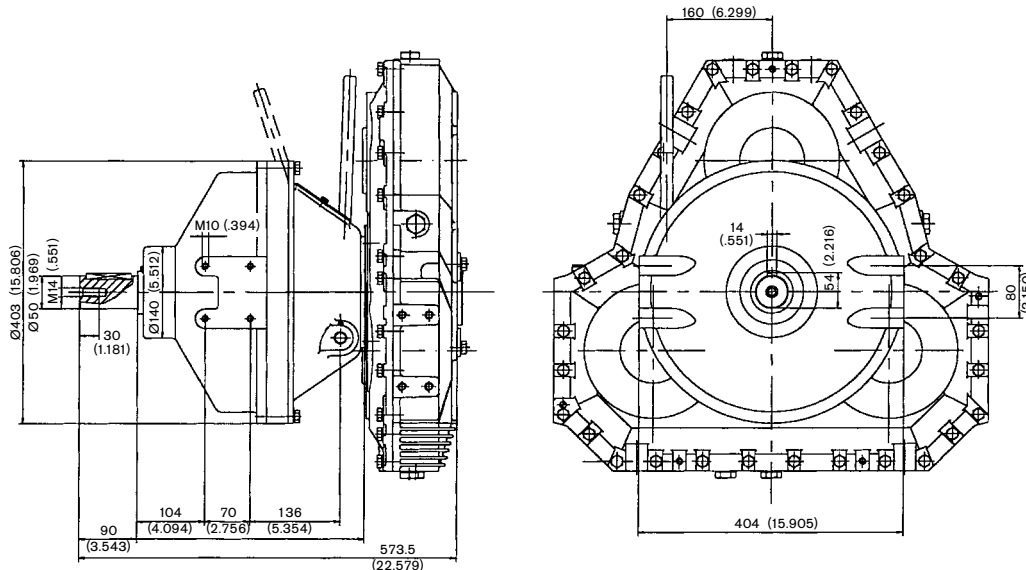

AM 345 TECHNICAL DATA

RATIO :1	MAX. INPUT TORQUE N-m (lbf-ft)	MAX. OUTPUT TORQUE PER PUMP PAD* N-m (lbf-ft)	MAX. INPUT SPEED RPM	MAX. OUTPUT SPEED RPM	OIL QUANTITY L (gal)
0.50	3187 (2350)	563 (415)	1950	3900	4.9 (1.29)
0.58	3154 (2325)	651 (480)	2050	3534	4.7 (1.24)
0.67	3052 (2250)	705 (520)	2200	3284	4.4 (1.16)
0.76	2984 (2200)	800 (590)	2300	3026	4.0 (1.06)
1.00	2767 (2040)	997 (735)	2600	2600	3.6 (0.95)
1.31	2509 (1850)	1065 (785)	3000	2290	3.0 (0.79)
1.48	2374 (1750)	1092 (805)	3200	2162	2.8 (0.74)

AM 345 MOMENT OF INERTIA DATA

RATIO :1	B kg-m ² (lb-ft ²)	BD 290 kg-m ² (lb-ft ²)	BD 2200 kg-m ² (lb-ft ²)	BD 3300 kg-m ² (lb-ft ²)	BDS 290 kg-m ² (lb-ft ²)	BDS 2200 kg-m ² (lb-ft ²)
0.51						
0.58						
0.67	0.2723 (6.46)	0.722 (17.14)	2.097 (49.77)	2.822 (66.97)	0.947 (22.48)	3.272 (77.65)
0.76	0.2436 (5.78)	0.694 (16.46)	2.069 (49.09)	2.794 (66.29)	0.919 (21.80)	3.244 (76.97)
1.00	0.1580 (3.75)	0.608 (14.43)	1.983 (47.06)	2.708 (64.26)	0.833 (19.77)	3.158 (74.94)
1.31	0.1452 (3.45)	0.595 (14.12)	1.970 (46.75)	2.695 (63.96)	0.820 (19.46)	3.145 (74.64)
1.48	0.1405 (3.33)	0.590 (14.01)	1.965 (46.64)	2.690 (63.84)	0.815 (19.35)	3.140 (74.52)

MODEL	WEIGHT kg (lb)
AM 345 B	154 (339)
AM 345 BD 290	188 (414)
AM 345 BD 2200	255 (562)
AM 345 BD 3300	298 (657)
AM 345 BDS 290	215 (474)
AM 345 BDS 2200	365 (805)

**INDEPENDENT MOUNT
WITH TWO PLATE 14" CLUTCH
AM 345 BDS 2200**

**INDEPENDENT MOUNT
WITH THREE PLATE 14"
CLUTCH
AM 345 BDS 3300**

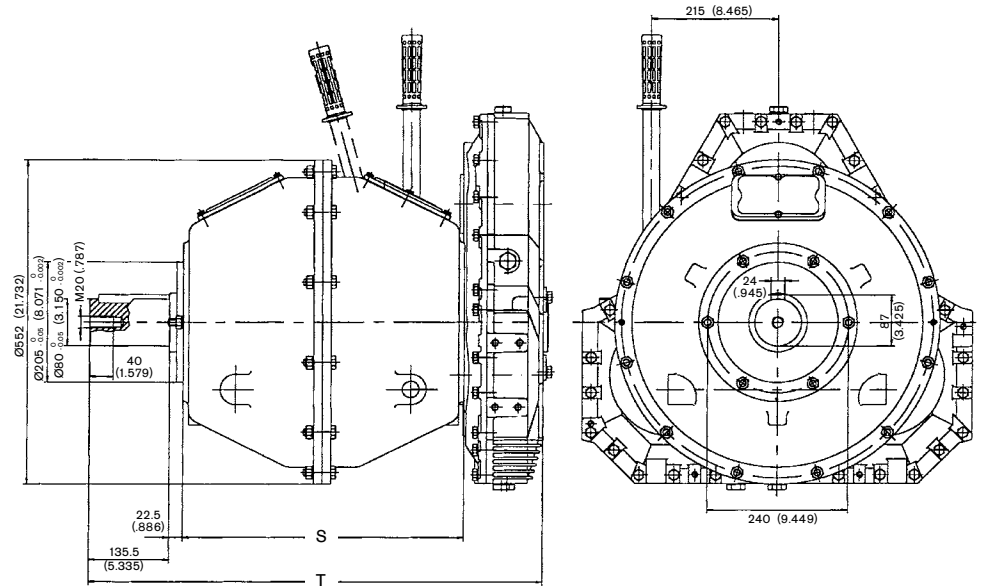

* Maximum output power and torque ratings are based on two pump pads.

Maximum torque and maximum speed may be limited by clutch option. Refer to Option Selection on page 24 for clutch limitations. Refer to pages 24-25 for input and Option Selection.

AM 450 MAXIMUM INPUT POWER 965 kW (1295 hp)

BASIC PUMP DRIVE AM 450 B

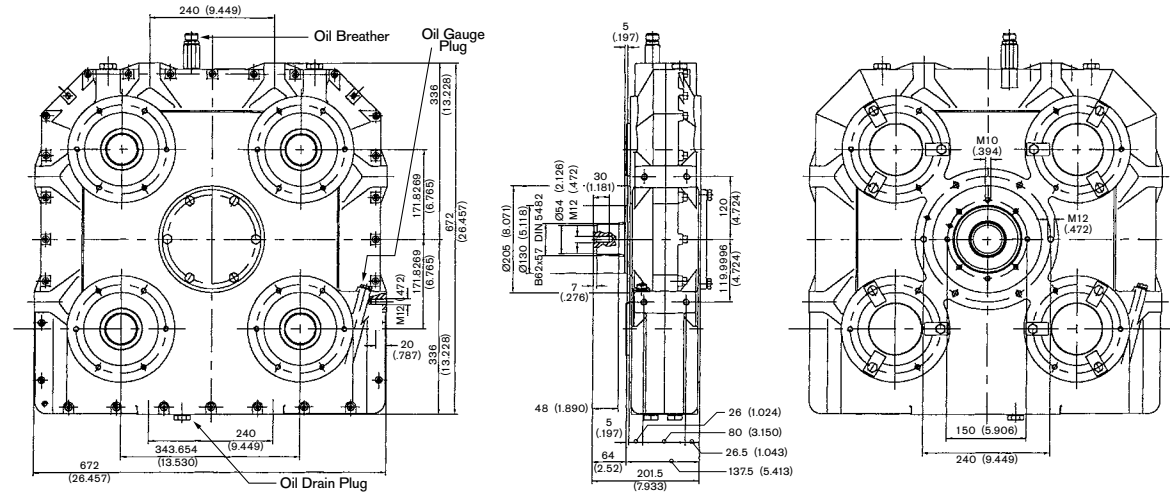

Four additional pump pads available on input side of drive.

MODEL	A	B
AM 450 BD 290	284.5 (11.20)	39.7 (1.563)
AM 450 BD 2200	373.5 (14.70)	25.4 (1.000)
AM 450 BD 3300	401.5 (15.81)	25.4 (1.000)

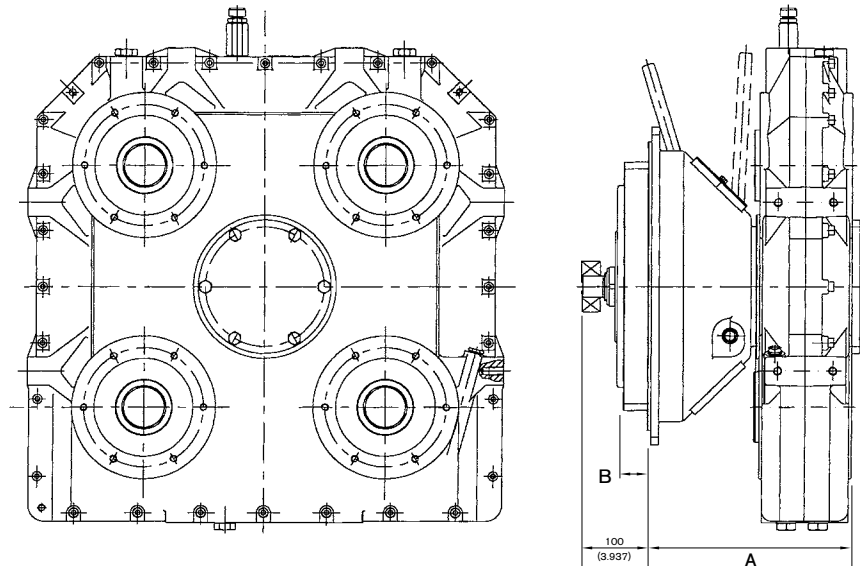

WITH TWO PLATE 11" CLUTCH AM 450 BD 290

WITH TWO PLATE 14" CLUTCH AM 450 BD 2200

WITH THREE PLATE 14" CLUTCH AM 450 BD 3300

INDEPENDENT MOUNT WITH TWO PLATE 11" CLUTCH AM 450 BDS 290

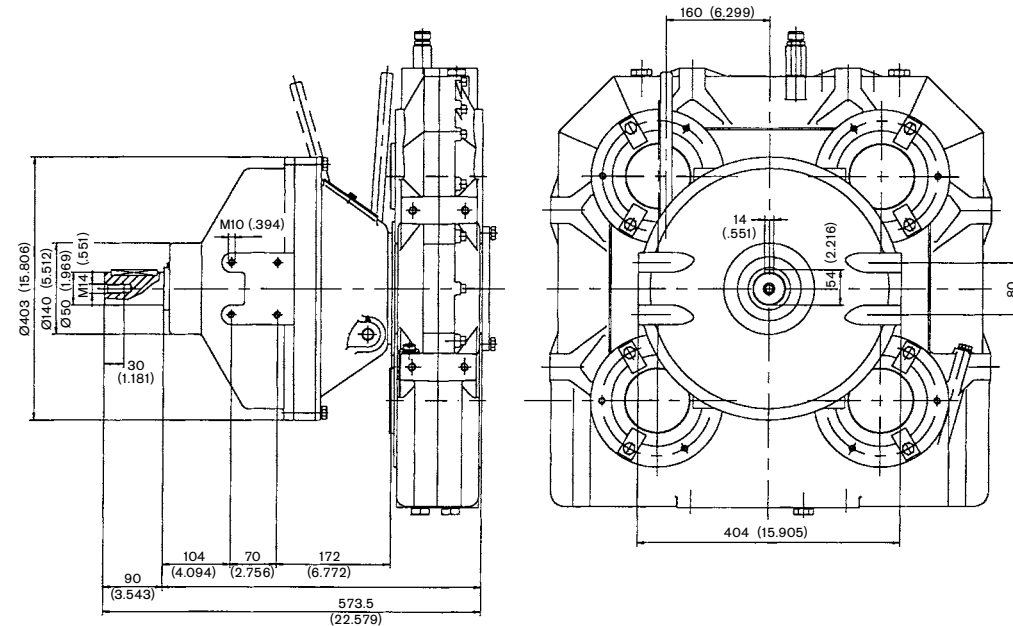

AM 450 TECHNICAL DATA

RATIO	MAX. INPUT TORQUE N-m (lbf-ft)	MAX. OUTPUT TORQUE PER PUMP PAD* N-m (lbf-ft)	MAX. INPUT SPEED RPM	MAX. OUTPUT SPEED RPM	OIL QUANTITY L (gal)
:1					
0.67	5561 (4100)	963 (710)	2000	2985	2.5 (0.66)
0.77	5425 (4000)	1072 (790)	2100	2727	2.5 (0.66)
.89	5154 (3800)	1173 (865)	2250	2528	2.3 (0.61)
1.00	5019 (3700)	1318 (972)	2400	2400	2.3 (0.61)

AM 450 MOMENT OF INERTIA DATA

RATIO	B kg-m ² (lb-ft ²)	BD 290 kg-m ² (lb-ft ²)	BD 2200 kg-m ² (lb-ft ²)	BD 3300 kg-m ² (lb-ft ²)	BDS 290 kg-m ² (lb-ft ²)	BDS 2200 kg-m ² (lb-ft ²)
:1						
0.67	0.6413 (15.22)	1.109 (26.32)	2.466 (58.53)	3.191 (75.73)	1.316 (31.24)	3.641 (86.41)
0.77	0.5777 (13.71)	1.045 (24.80)	2.403 (57.02)	3.128 (74.22)	1.253 (29.73)	3.578 (84.90)
0.89	0.4527 (10.74)	0.920 (21.84)	2.278 (54.05)	3.003 (71.26)	1.128 (26.76)	3.453 (81.93)
1.00	0.4445 (10.55)	0.895 (21.23)	2.270 (53.86)	2.995 (71.06)	1.120 (26.57)	3.445 (81.74)

MODEL	WEIGHT kg (lb)
AM 450 B	205 (452)
AM 450 BD 290	271 (597)
AM 450 BD 2200	338 (745)
AM 450 BD 3300	381 (840)
AM 450 BDS 290	298 (657)
AM 450 BDS 2200	448 (988)

INDEPENDENT MOUNT WITH TWO PLATE 14" CLUTCH AM 450 BDS 2200

INDEPENDENT MOUNT WITH THREE PLATE 14" CLUTCH AM 450 BDS 3300

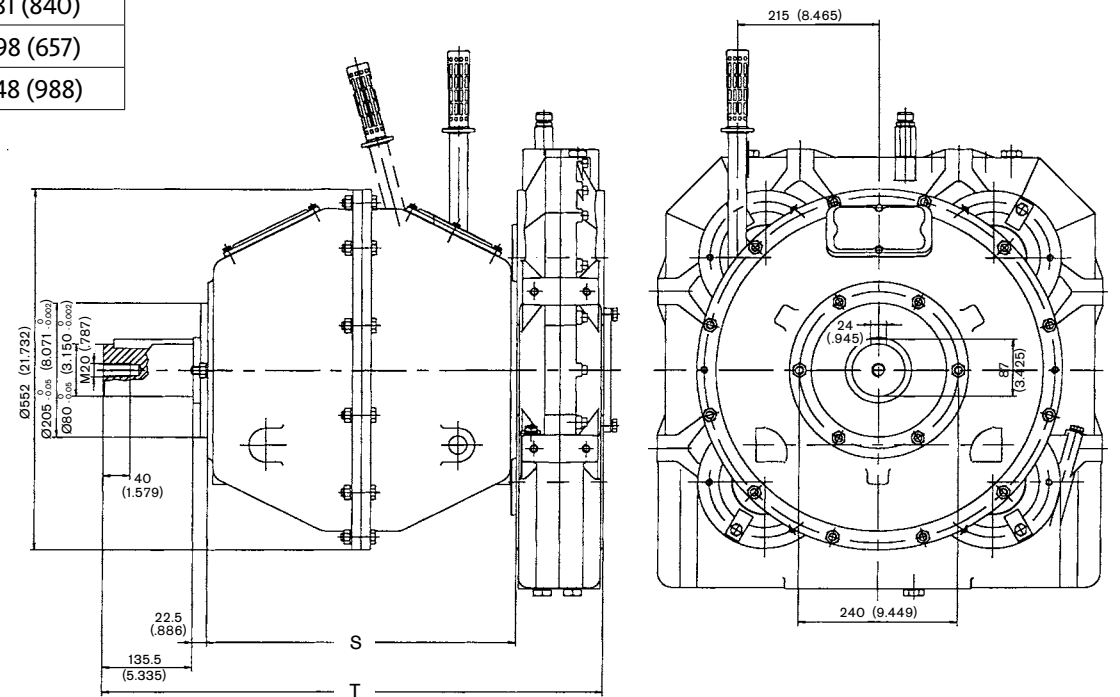

* Maximum output power and torque ratings are based on four pump pads.

Maximum torque and maximum speed may be limited by clutch option. Refer to Option Selection on page 24 for clutch limitations. Refer to pages 24-25 for input and Option Selection.

OPTION SELECTION AM 230-232-345-450

INPUT CONFIGURATIONS

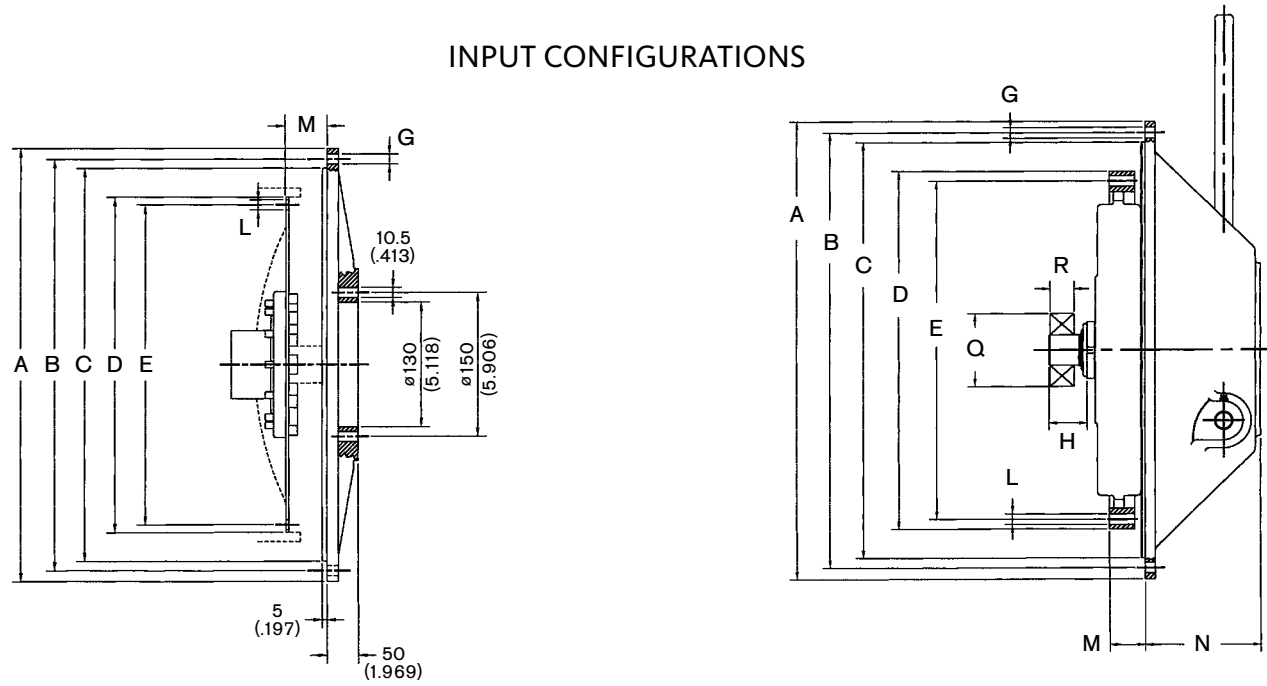

DIMENSIONS				
mm (in)	SAE 1	SAE 2	SAE 3	SAE 4
A	552.00 (21.732)	489.00 (19.252)	451.00 (17.756)	403.22 (15.875)
B	530.22 (20.875)	466.72 (18.375)	428.62 (16.825)	381.00 (15.000)
C	511.17 (20.125)	447.67 (17.625)	409.57 (16.125)	361.95 (14.250)
G	12.00 (0.472)	11.00 (0.433)	11.00 (0.433)	11.00 (0.433)
NUMBER OF HOLES	12	12	12	12

mm (in)	BD 290	BD 2200	BD 3300
D	352.42 (13.875)	466.72 (18.375)	466.72 (18.375)
E	333.37 (13.125)	438.15 (17.250)	438.15 (17.250)
H	37 (1.457)	37 (1.457)	37 (1.457)
L	10.5 (0.413)	10.5 (0.413)	10.5 (0.413)
NUMBER OF HOLES	8	8	8
M	39.7 (1.563)	25.4 (1.000)	25.4 (1.000)
N	147 (5.787)	236 (9.291)	264 (10.394)
Q	72 (2.835)	80 (3.150)	80 (3.150)
R	27 (1.063)	31 (1.220)	31 (1.220)

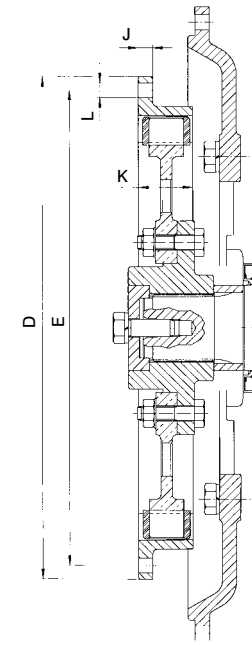

RUBBER BLOCK DRIVE INPUT

RUBBER BLOCK DRIVE MAX. TORQUE RATING		
FLYWHEEL	CONTINUOUS N-m (lbf-ft)	INTERMEDIATE N-m (lbf-ft)
10"	310 (229)	400 (295)
11.5"	480 (354)	620 (457)
14"	940 (693)	1210 (892)

CLUTCH OPTIONS			
CLUTCH MODEL	SAE HOUSING	MAX. INPUT TORQUE N-m (lbf-ft)	MAX. INPUT SPEED RPM
BD 290	1-2-3	880 (649)	2900
BD 2200	1	1960 (1446)	2400
BD 3300	1	2980 (2198)	2400

DIMENSIONS						
FLYWHEEL	D mm (in)	E mm (in)	J mm (in)	K mm (in)	L mm (in)	NUMBER OF HOLES
10"	314.32 (12.375)	295.27 (11.625)	10.00 (0.394)	34.00 (1.339)	10.30 (0.406)	8
11.5"	352.42 (13.875)	333.37 (13.125)	10.00 (0.394)	38.00 (1.496)	10.30 (0.406)	8
14"	466.72 (18.375)	438.15 (17.250)	41.00 (1.614)	41.00 (1.614)	13.502 (0.531)	8

AM 365 MAXIMUM INPUT POWER 885 kW (1185 hp)

BASIC PUMP DRIVE WITH SAE 1 HOUSING AM 365 B

Three additional drives
available on input side
of drive

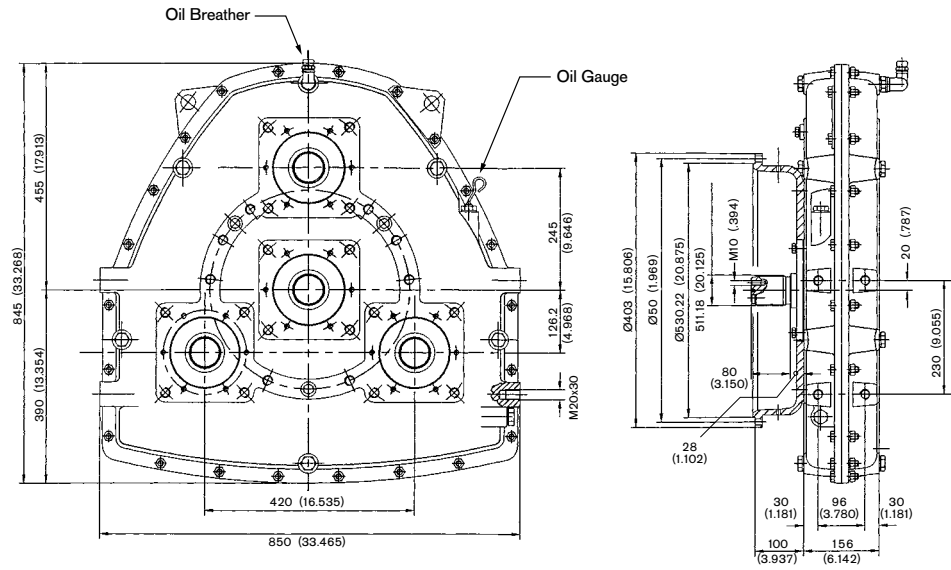

AM 365 TECHNICAL DATA

RATIO :1	MAX. INPUT TORQUE N-m (lbf-ft)	MAX. OUTPUT TORQUE PER PUMP PAD* N-m (lbf-ft)	MAX. INPUT SPEED RPM	MAX. OUTPUT SPEED RPM	OIL QUANTITY L (gal)	MOMENT OF INERTIA kg-m ² (lbf-ft ²)
0.69	3866 (2850)	936 (690)	1800	2609	14.5 (3.83)	0.4391 (10.42)
0.81	3764 (2775)	1031 (760)	2100	2593	14.5 (3.83)	0.4255 (10.10)
1.00	3662 (2700)	1241 (915)	2200	2200	14.5 (3.83)	0.3626 (8.60)
1.23	3425 (2525)	1329 (980)	2400	1951	14.5 (3.83)	0.3428 (8.13)
1.45	3255 (2400)	1397 (1030)	2500	1724	14.5 (3.83)	0.2794 (6.63)

MODEL	WEIGHT kg (lb)
BASIC UNIT	215 (474)

INPUT OPTIONS
SAE 1 HOUSING
65 mm CYLINDRICAL KEYED SHAFT
SPLINED SHAFT

PUMP ADAPTATIONS
SAE A, B, C, D AND E

*Maximum output power and torque ratings are based on three pump pads. Other configurations may be available. Contact Twin Disc, Incorporated.

AM 480 MAXIMUM INPUT POWER 705 kW (945 hp)

BASIC PUMP DRIVE AM 480 B

Four additional
drives available on
input side of drive

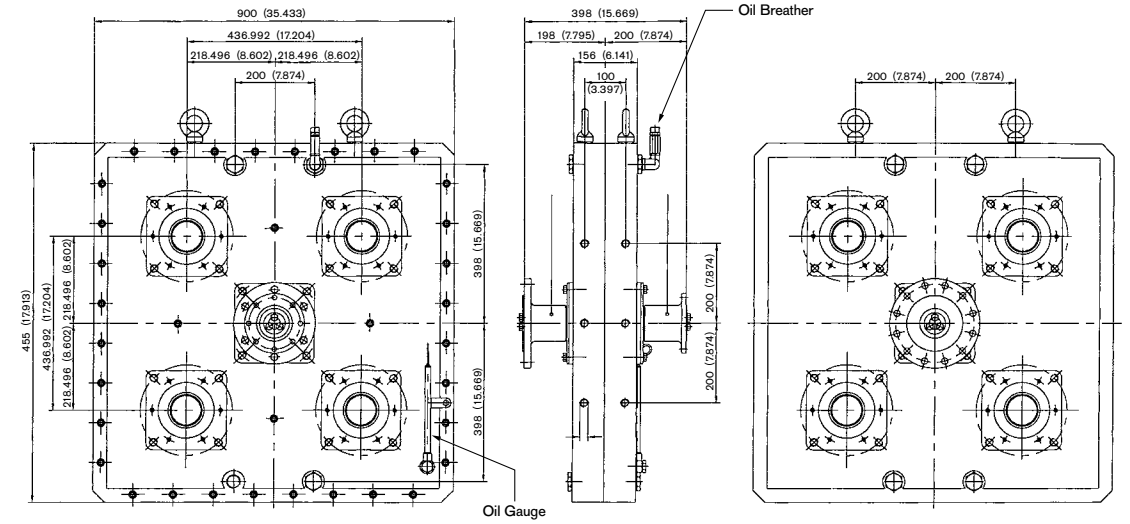

AM 480 TECHNICAL DATA

RATIO :1	MAX. INPUT TORQUE N-m (lbf-ft)	MAX. OUTPUT TORQUE PER PUMP PAD* N-m (lbf-ft)	MAX. INPUT SPEED RPM	MAX. OUTPUT SPEED RPM	OIL QUANTITY L (gal)	MOMENT OF INERTIA kg-m ² (lbf-ft ²)
0.72	5900 (4350)	1072 (790)	1500	2083	7.3 (1.93)	1.4705 (34.90)
0.87	5595 (4125)	1241 (915)	1650	1897	7.0 (1.85)	1.3524 (32.09)
1.00	5493 (4050)	1322 (975)	1750	1750	6.9 (1.82)	1.2394 (29.41)
1.15	5222 (3850)	1390 (1025)	1900	1652	6.7 (1.77)	1.1568 (27.45)

MODEL	WEIGHT kg (lb)
BASIC UNIT	350 (772)

INPUT OPTIONS
SAE 1 HOUSING
65 mm CYLINDRICAL KEYED SHAFT
SPLINED SHAFT

PUMP ADAPTATIONS
SAE A, B, C, D AND E

*Maximum output power and torque ratings are based on four pump pads. Other configurations may be available. Contact Twin Disc, Incorporated.

PUMP DRIVE SELECTION PROCEDURE

Use the following fundamental information to select a pump drive product:

1. Number and type of hydraulic pumps to be applied.
2. Maximum torque absorbed by the pump or pumps on each output of the pump drive.
3. Maximum power entering the pump drive from the prime mover. This should be calculated by multiplying net engine power by an appropriate service factor from Table 1.

Compare the size of the hydraulic pumps to the selected pump drive installation dimensions to determine if proper clearance exists to mount the pumps on the pump drive.

Select the desired input configuration:

1. B – Basic mount, either with drive plate or rubber block
2. BD – Engine mounted clutch input
3. BDS – Independently mounted clutch input

If a BD or BDS option is selected, verify that the input speed does not exceed the maximum allowable speed for the selected clutch. Also verify that the maximum input torque is at least 20% below the maximum torque rating of the clutch.

Select the desired gear ratio from those listed on the technical information pages of this catalog.

Select the proper output option for pump adaptation.

1. SAE adaptors are available for all pump drives.
2. Other adaptations may be available. Contact Twin Disc, Incorporated for non-SAE adaptations.

TECHNICAL INFORMATION

THERMAL CAPACITY

It is advisable to check the pump drive temperature during the first hours of work, assuring that the temperature of the oil doesn't exceed 105°C (221°F). Depending on input power and application, a cooling system may be necessary.

Models AM 220, 330, 230, 232, 345, 450, 365, can be equipped (upon request) with a cooling system consisting of an oil circulation pump on the input shaft on the pump side, and oil/water heat exchanger and relevant pipe fittings.

LUBRICATION

Use gear lube oils with EP additive and minimum viscosity index of 95.

Choose oil based on ambient temperature. (See Table above)

Table 1 – Service Factors

Prime Mover	Duration of Service	Driven Machine Load Classifications		
		Uniform	Moderate Shock	Heavy Shock
Electric Motor, Steam Turbine, or Hydraulic Motor	Occasional ½ hr. per day	0.50	0.80	1.25
	Intermittent 3 hrs. per day	0.80	1.00	1.50
	Over 3 hrs. up to and including 10 hrs. per day	1.00	1.25	1.75
	Over 10 hrs. per day	1.25	1.50	2.00
Multi-Cylinder Internal Combustion Engine	Occasional ½ hr. per day	0.80	1.00	1.50
	Intermittent 3 hrs. per day	1.00	1.25	1.75
	Over 3 hrs. up to and including 10 hrs. per day	1.25	1.50	2.00
	Over 10 hrs. per day	1.50	1.75	2.25

TABLE 1 OIL

AMBIENT TEMPERATURE		-20°C/+5°C (-4°F/41°F)	+5°C/+40°C (41°F/104°F)	-30°C/+65°C (-22°F/149°F)
Viscosity	ISO 3448	VG 100	VG 150	VG 150-220
	IV min	95	95	165
MOBIL		Mobilgear 627	Mobilgear 629	Mobil SHC 629 Mobilgear SHC 150
AGIP		Blasia 100	Blasia 150	Blasia 220
BP MACH		GR XP 100	BR XP 100	SGR XP 220
CASTROL		Alpha SP 100	Alpha SP 150	Alpha SN6
ELF		Reductelf SP 100	Reductelf SP 150	Oritis 125 MS
ESSO		Spartan EP 100	Spartan EP 150	C. Oil Lg 150
I.P.		Mellana 100	Mellana 150	Telesia Oil 150
SHELL		Omala Oil 100	Omala Oil 150	
TOTAL		Carter EP 100N	Carter EP 150	

INSTALLATION

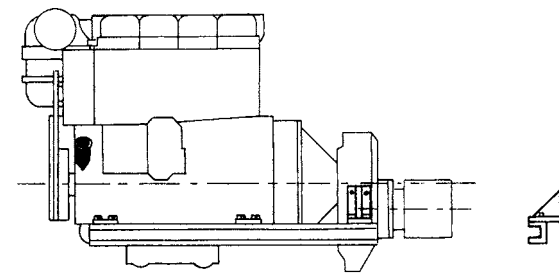

Pump drive with pumps weighing less than 100 kg (220 lb). Normal support brackets.

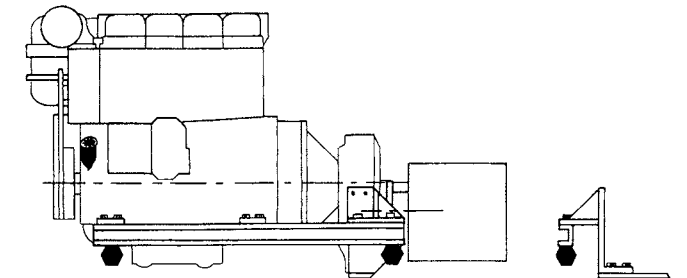

Pump drive with pumps of total weight more than 100 kg (220 lb). The support brackets must be close to pump drive/pumps center of gravity.

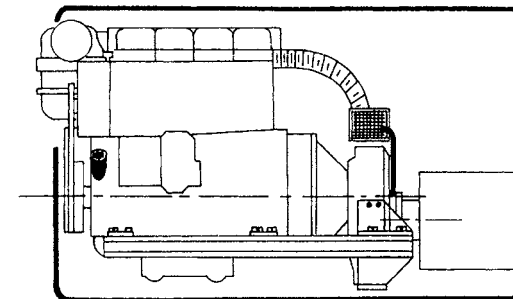

Pump drive in closed surrounding without ventilation. A cooling system is needed.

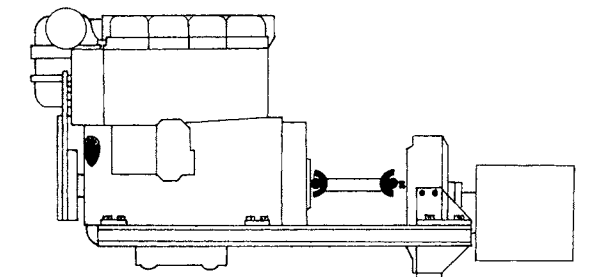

Pump drive driven by cardan joint. The support brackets must be close to pump drive/pumps center of gravity.

SAE HYDRAULIC PUMP STANDARD

SAE Standard J744 is intended to provide a progression of standard mounting flanges and shafts that are dimensionally compatible for hydraulic pumps and motors used on construction and industrial machinery and equipment.

Dimensions and tolerances shown are millimeter (inch).

Dimensions of 2 and 4 Bolt Pump and Motor Mounting Flanges

I.D. CODE	PILOT DIMENSIONS A NOTED	PILOT DIMENSIONS W NOTED	PILOT DIMENSIONS X MIN	PILOT DIMENSIONS Y MAX	2 BOLT TYPE K	2 BOLT TYPE M NOTED	4 BOLT TYPE S	4 BOLT TYPE R NOTED
50 ⁻¹	50.80	6.4	—	0.8	82.6	10.3	—	—
(A-A)	(2.000)	(0.250)	—	(0.03)	(3.250)	(0.406)	—	—
82 ⁻¹	82.55	6.4	—	0.8	106.4	11.1	—	—
(A)	(3.250)	(0.250)	—	(0.03)	(4.188)	(0.438)	—	—
101 ⁻¹	101.60	9.7	5.1	1.5	146.0	14.3	89.8	14.3
(B)	(4.000)	(0.380)	(2.00)	(0.06)	(5.750)	(0.562)	(3.536)	(0.562)
127 ⁻¹	127.00	12.7	6.4	1.5	181.0	17.5	114.5	14.3
(C)	(5.000)	(0.500)	(2.50)	(0.06)	(7.125)	(0.688)	(4.508)	(0.562)
152 ⁻¹	152.50	12.7	7.0	1.5	228.6	20.6	161.6	20.6
(D)	(6.000)	(0.500)	(2.75)	(0.06)	(9.000)	(0.812)	(6.364)	(0.812)
165 ⁻¹	165.10	15.9	7.0	2.3	317.5	27.0	224.5	20.6
(E)	(6.500)	(0.625)	(2.75)	(0.09)	(12.500)	(1.062)	(8.839)	(0.812)

Dimensions of Straight Shafts – Without Thread

I.D. CODE	STRAIGHT SHAFT D _{SI} MAX	STRAIGHT SHAFT D _{SI} MIN	STRAIGHT SHAFT L _S	STRAIGHT SHAFT F NOTED	2 BOLT E NOTED	2 BOLT L _I OPTIONAL
13 ⁻¹	12.70	12.67	19	14.07	3.18	—
(A-A)	(0.500)	(0.499)	(0.750)	(0.554)	(0.125)	—
16 ⁻¹	15.88	15.85	24	17.60	3.97	51
(A)	(0.625)	(0.624)	(0.938)	(0.693)	(0.1563)	(2.00)
22 ⁻¹	22.22	22.20	33	24.90	6.35	63
(B)	(0.875)	(0.874)	(1.312)	(0.982)	(0.250)	(2.50)
25 ⁻¹	25.40	25.35	38	28.10	6.35	70
(B-B)	(1.000)	(0.998)	(1.500)	(1.106)	(0.250)	(2.75)
32 ⁻¹	31.75	31.70	48	35.20	7.94	76
(C)	(1.250)	(1.248)	(1.875)	(1.386)	(0.3125)	(3.00)
38 ⁻¹	38.10	38.05	54	42.27	9.52	83
(C-C)	(1.500)	(1.498)	(2.125)	(1.664)	(0.375)	(3.25)
44 ⁻¹	44.45	44.40	67	49.30	11.11	92
(D & E)	(1.750)	(1.748)	(2.625)	(1.941)	(0.4375)	(3.62)

FIGURE 1 – DIMENSIONS OF 2 AND 4 BOLT PUMP AND MOTOR MOUNTING FLANGES

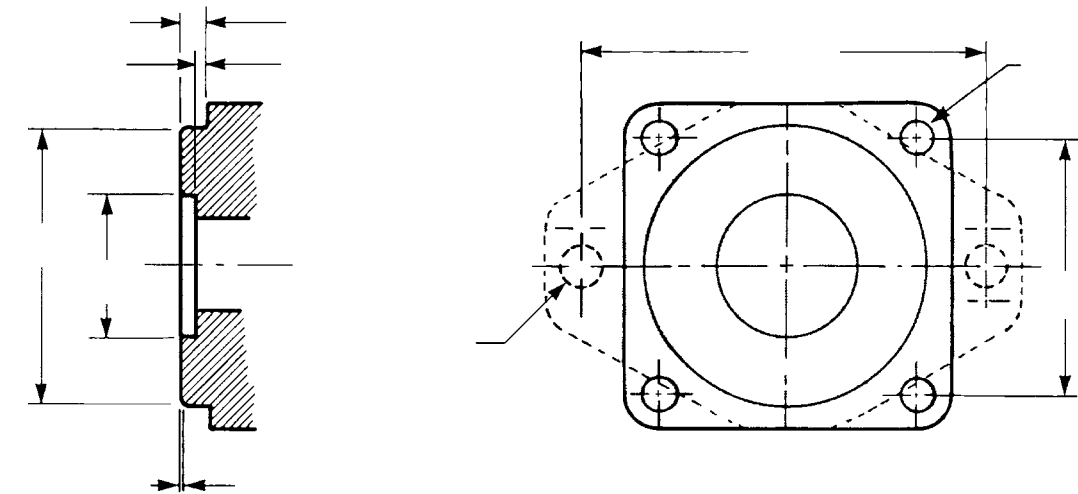

FIGURE 2 – DIMENSIONS OF STRAIGHT SHAFTS – WITHOUT THREAD

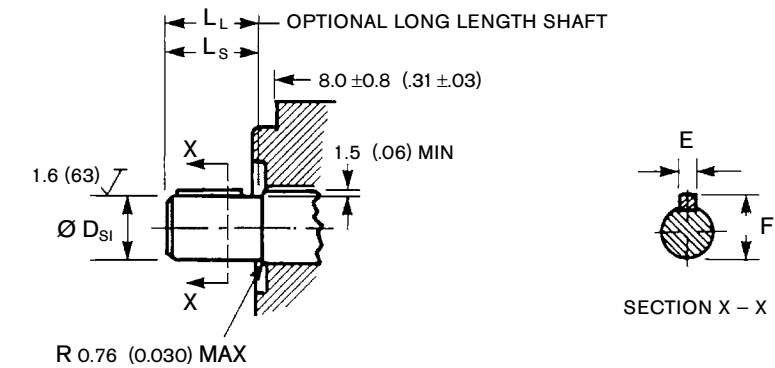
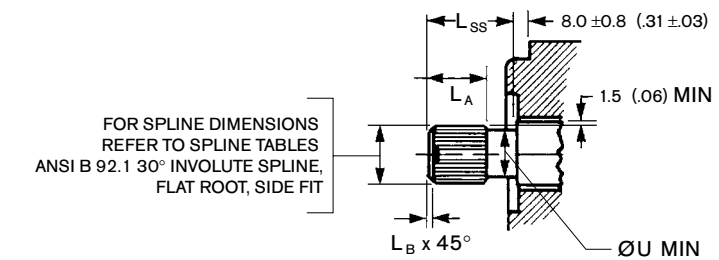

FIGURE 3 – DIMENSIONS OF 30° INVOLUTE SPLINE SHAFTS



Dimensions of 30 Degrees Involute Spline Shafts

SPLINE	U min	L _A	L _{SS} ¹	L _B min
9T 20/40 DP	9.40 (0.3700)	5.1 (0.20)	19 (0.750)	1.5 (0.06)
9T 16/32 DP	11.81 (0.4650)	7.6 (0.30)	24 (0.938)	1.5 (0.06)
13T 16/32 DP	18.16 (0.7150)	10.2 (0.40)	33 (1.312)	1.5 (0.06)
15T 16/32 DP	21.34 (0.8400)	12.7 (0.50)	38 (1.500)	1.5 (0.06)
14T 12/24 DP	26.42 (1.0400)	15.2 (0.60)	48 (1.875)	2.3 (0.09)
17T 12/24 DP	32.77 (1.2900)	17.8 (0.70)	54 (2.125)	2.3 (0.09)
13T 8/16 DP	36.63 (1.4420)	20.3 (0.80)	67 (2.625)	3.0 (0.12)

SAE ENGINE FLYWHEEL HOUSING AND MATING HOUSING FLANGES

SAE Standard J617 is intended to achieve standardization in the design of engine flywheel housings and mating flanges to assure compatibility. Dimensions and tolerances shown are millimeter (inch).

FLYWHEEL HOUSING

Figure 1 and Tables 1A and 1B furnish the dimensions and the hole patterns for dry type engine flywheel housings.

MATING HOUSING FLANGES

The mating housing flange pilot diameter shall be 6.4 (0.25) long, and its lead-in chamfer shall not exceed 2.0 (0.08) in length. The fillet radius between the mounting flange face and the pilot diameter shall not exceed 1.0 (0.04) R.

The diameter of the pilot on the flange of the mating housing shall be the same as the nominal diameter of the bore in the flywheel housing with tolerances as shown in Table 2. Tolerances for pilot diameter and flange face runout and hole sizes are also shown in Table 2.

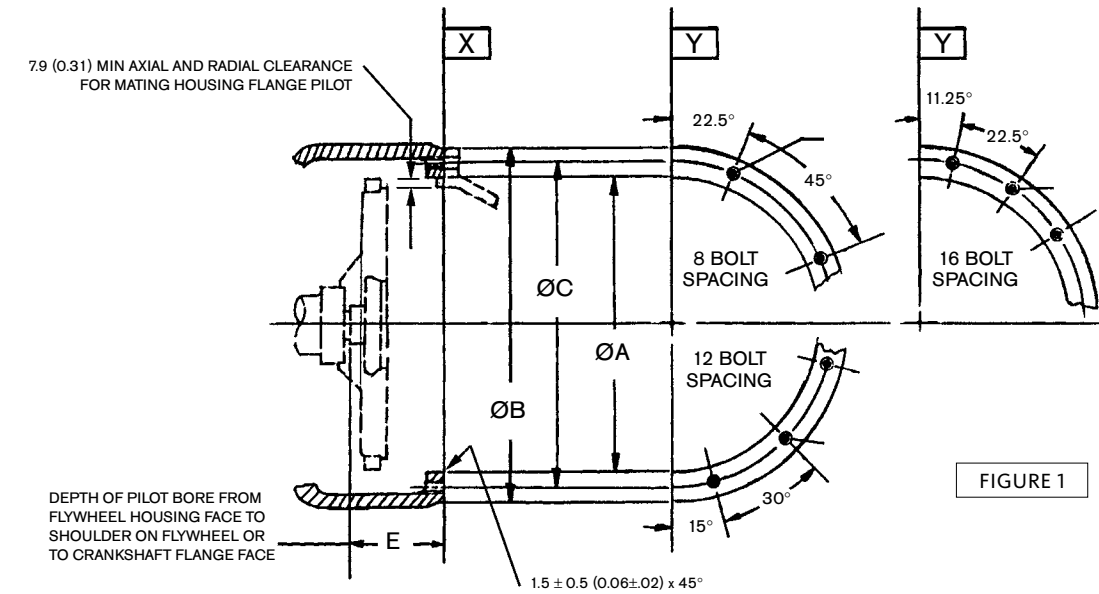

FIGURE 1

TABLE 1B Flywheel Housing Dimensions, mm (in) – See Figure 1

SAE NO. ¹	E NOMINAL DIMENSION	E TOLERANCE ±	TAPPED MOUNTING HOLES ^{1,5,7,8} NUMBER	TAPPED MOUNTING HOLES ^{1,5,7,8} METRIC	TAPPED MOUNTING HOLES ^{1,5,7,8} INCH
6	71.4 (2.81)	1.52 (0.06)	8	M10 X 1.50	3/8 – 16
5	71.4 (2.81) ⁴	1.52 (0.06)	8	M10 X 1.50	3/8 – 16
4	100.1 (3.94) ³	1.52 (0.06)	12	M10 X 1.50	3/8 – 16
3	100.1 (3.94)	1.52 (0.06)	12	M10 X 1.50	3/8 – 16
2	100.1 (3.94)	1.52 (0.06)	12 ⁶	M10 X 1.50	3/8 – 16
1	100.1 (3.94) ²	1.52 (0.06)	12 ⁶	M10 X 1.50	7/16 – 14
1/2	100.1 (3.94) ²	1.52 (0.06)	12	M12 X 1.75	1/2 – 13
0	100.1 (3.94) ²	2.03 (0.08)	16	M12 X 1.75	1/2 – 13
00	100.1 (3.94) ²	2.03 (0.08)	16	M12 X 1.75	1/2 – 13

¹ For differentiating housings using metric tapped holes, add (“M”) designation to the housing size: Example: SAE 2M indicating SAE 2 flywheel housing with metric tapped holes.

² An “E” dimension of 133.4 (5.25) is optional for flywheel housing numbers 1, 1/2, 0 and 00 when multi-plate clutches are used.

³ An “E” dimension of 71.4 (2.81) is required for SAE No. 4 housing when 6/2 or 7/2 size driving ring type overcenter clutches conforming to SAE J621 are used.

⁴ An “E” dimension of 100.1 (3.94) is required for SAE No. 5 housing when an 8 size driving ring type overcenter clutch, conforming to SAE J621 is used.

⁵ Tapped holes shall be equally spaced on each side of the vertical centerline “Y” axis. See Figure 1.

⁶ Optional 24 bolt spacing for SAE No. 1 and 2 aluminum housings.

⁷ Tapped holes shall be threaded in accordance with:
Metric: ISO Coarse pitch series thread class fit 6H as specified in ISO 965/11.
Inch: UNC Class 2B of ANSI B1.1 screw threads.

⁸ Minimum bolt thread engagement length shall be 1.5 times the nominal bolt diameter for “Gray Iron” housing for 2 times the nominal bolt diameter for aluminum housings. Recommended minimum thread engagement length values are for SAE Grade 8 bolt and torque application.

TABLE 1A Flywheel Housing Dimensions, mm (in) – See Figure 1

SAE NO. ¹	A (PILOT DIA) NOMINAL DIMENSION	A (PILOT DIA) TOLERANCE -0.000 FIM	PILOT BORE “A” AND FACE “X” RUNOUT TOLERANCE (T) ²	B	C (BOLT CIRCLE)
6	266.70 (10.500)	+0.13 (0.005)	0.18 (0.007)	307.8 (12.12)	285.75 (11.250)
5	314.32 (12.375)	+0.13 (0.005)	0.20 (0.008)	355.6 (14.00)	333.38 (13.125)
4	361.95 (14.250)	+0.13 (0.005)	0.23 (0.009)	403.4 (15.88)	381.00 (15.000)
3	409.58 (16.125)	+0.13 (0.005)	0.25 (0.010)	450.8 (17.75)	428.62 (16.875)
2	447.68 (17.625)	+0.13 (0.005)	0.28 (0.011)	489.0 (19.25)	466.72 (18.375)
1	511.18 (20.125)	+0.20 (0.008)	0.30 (0.012)	552.4 (21.75)	530.22 (20.875)
1/2	584.20 (23.000)	+0.20 (0.008)	0.36 (0.014)	647.7 (25.50)	619.12 (24.375)
0	647.70 (25.500)	+0.25 (0.010)	0.41 (0.016)	711.2 (28.00)	679.45 (26.750)
00	784.40 (31.000)	+0.25 (0.010)	0.48 (0.019)	882.6 (34.75)	850.90 (33.500)

¹ For differentiating housings using metric tapped holes, add (“M”) designation to the housing size: Example: SAE 2M indicating SAE 2 flywheel housing with metric tapped holes.

² Figures shown for bore and face runout are full indicator readings (FIM). Runout to be measured on assembled engine mounted on its supports and held in its normal operating position. For measuring procedure see SAE J1033.

TABLE 2 Tolerances and Hole Sizes for Mating Transmission Housing Flanges, mm (in)

HOUSING SAE NO.	PILOT DIAMETER “A” TOLERANCE +0	PILOT DIAMETER “A” AND FACE “X” RUNOUT TOLERANCE (t) FIM (FULL INDICATOR READING)	DRILL THRU HOLE METRIC BOLT SIZE	DRILL THRU HOLE METRIC HOLE SIZE MM	DRILL THRU HOLE INCH BOLT SIZE	DRILL
6, 5, 4	-0.13 (-0.005)	0.13 (0.005)	M10	11.20 ¹	3/8	0.422 ¹
3, 2	-0.13 (-0.005)	0.20 (0.008)	M10	11.20 ¹	3/8	0.422 ¹
1	-0.13 (-0.005)	0.20 (0.008)	M10	11.20	7/16	0.484
1/2, 0, 00	-0.20 (-0.008)	0.25 (0.010)	M12	13.50	1/2	0.563

¹ These holes may be drilled to 11.00 (0.433) diameter to provide common hole size for metric and inch bolts. 3/8 bolts should be used with thick hard washers.

SAE ENGINE FLYWHEEL STANDARD

SAE Standard J620 defines flywheel configurations for industry standardization, interchangeability and compatibility. Table 1 and Figure 1 give the dimensions for the flywheels. Dimensions and tolerances shown are millimeter (inch).

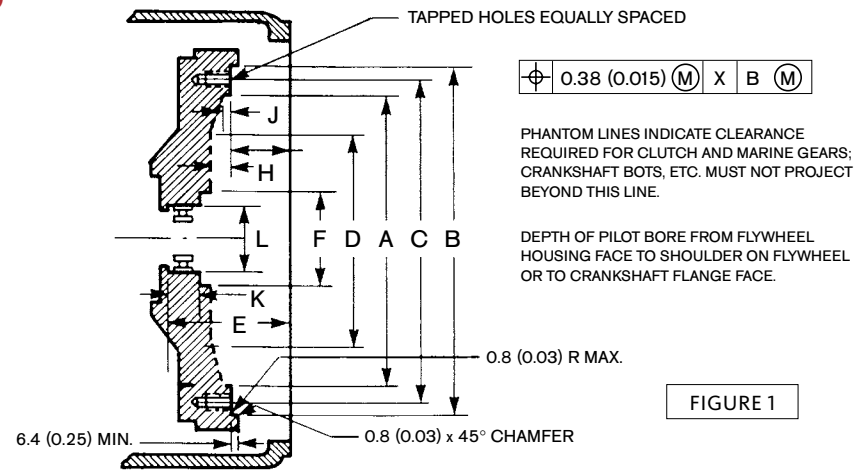

TABLE 1 Dimensions of Flywheels, mm (in)

CLUTCH SIZE	A	B ^{1,2}	C	D	E ^{5,11}	F
165 (6.5)	184.2 (7.25)	215.90 (8.500)	200.02 (7.875)	127.0 (5.00)	71.4 (2.81)	63.5 (2.50)
190 (7.5)	206.2 (8.12)	241.30 (9.500)	222.25 (8.750)	—	71.4 (2.81)	63.5 (2.50)
200 (8)	225.6 (8.88)	263.52 (10.375)	244.48 (9.625)	—	100.1 (3.94)	76.2 (3.00)
255 (10) ⁶	276.4 (10.88)	314.32 (12.375)	295.28 (11.625)	196.8 (7.75)	100.1 (3.94)	76.2 (3.00)
290 (11.5) ⁷	314.5 (12.38)	352.42 (13.875)	333.38 (13.125)	203.2 (8.00)	100.1 (3.94)	—
355 (14) ⁸	409.4 (16.12)	466.72 (18.375)	438.15 (17.250)	222.2 (8.75)	100.1 (3.94)	101.6 (4.00)
405 (16)	460.2 (18.12)	517.52 (20.375)	488.95 (19.250)	254.0 (10.00)	100.1 (3.94)	104.6 (4.12)
460 (18) ⁹	498.3 (19.62)	571.50 (22.500)	542.92 (21.375)	—	100.1 (3.94)	104.6 (4.12)
530 (21) ¹⁰	584.2 (23.00)	673.10 (26.500)	641.35 (25.250)	—	100.1 (3.94)	146.0 (5.75)
610 (24)	644.7 (25.38)	733.42 (28.875)	692.15 (27.250)	—	100.1 (3.94)	146.0 (5.75)

CLUTCH SIZE	G ⁵	H	J	K ^{3,11}	L ^{2,3,22}	TAPPED HOLES ⁴ NO.	TAPPED HOLES ⁴ SIZE
165 (6.5)	30.2 (1.19)	12.7 (0.50)	9.7 (0.38)	17.5 (0.69)	52.000 (2.0472)	6	(⁵ / ₁₆ -18)
190 (7.5)	30.2 (1.19)	12.7 (0.50)	12.7 (0.50)	17.5 (0.69)	52.000 (2.0472)	8	(⁵ / ₁₆ -18)
200 (8)	62.0 (2.44)	12.7 (0.50)	12.7 (0.50)	19.0 (0.75)	62.000 (2.4409)	6	(³ / ₈ -16)
255 (10)	53.8 (2.12)	15.7 (0.62)	12.7 (0.50)	28.4 (1.12)	72.000 (2.8346)	8	(³ / ₈ -16)
290 (11.5)	39.6 (1.56)	28.4 (1.12)	22.4 (0.88)	31.8 (1.25)	72.000 (2.8346)	8	(³ / ₈ -16)
355 (14)	25.4 (1.00)	28.4 (1.12)	22.4 (0.88)	38.1 (1.50)	80.000 (3.1496)	8	(¹ / ₂ -13)
405 (16)	15.7 (0.62)	28.4 (1.12)	22.4 (0.88)	44.4 (1.75)	100.000 (3.9370)	8	(¹ / ₂ -13)
460 (18)	15.7 (0.62)	31.8 (1.25)	31.8 (1.25)	44.4 (1.75)	100.000 (3.9370)	6	(⁵ / ₈ -11)
530 (21)	0.0 (0.00)	31.8 (1.25)	31.8 (1.25)	57.2 (2.25)	130.000 (5.1181)	12	(⁵ / ₈ -11)
610 (24)	0.0 (0.00)	31.8 (1.25)	31.8 (1.25)	57.2 (2.25)	130.000 (5.1181)	12	(³ / ₄ -10)

NOTE - Suggested tolerances are to be measured on assembled engine; for measuring procedure, see SAE J1033.

¹ Diameter tolerance of driving-ring pilot bore 'B' is + 0.13 (0.005), -0.000; maximum eccentricity is 0.13 (0.005) total indicator reading (see footnote 2); face runout maximum total indicator reading is 0.0005 times the measured diameter. Diameter tolerance for mating driving ring, etc., pilot diameter is +0.000, -0.13 (0.005)

² Eccentricity between driving-ring pilot bore 'B' and pilot bearing bore 'L' is not to exceed 0.20 (0.008) total indicator reading.

³ 'K' is length of bore for pilot bearing; 'L' is nominal diameter of bearing. Diameter and fit are to suit installation. Maximum eccentricity is 0.13 (0.005) total indicator reading. (See footnote 2.)

⁴ Tapped holes shall be threaded in accordance with UNC Class 2B tolerances of ANSI/ASME B1.1 screw threads, and the minimum length of thread engagement shall be 1.5 times the nominal diameter.

FLUID POWER FORMULAS

FORMULA FOR:	METRIC	U.S. CUSTOMARY
Fluid Pressure	Pressure (kPa) = $\frac{10 \times \text{Force (N)}}{\text{Area (cm}^2\text{)}}$	Pressure (psi) = $\frac{\text{Force (lb)}}{\text{Area (in}^2\text{)}}$
Cylinder Area	Area (cm ²) = $\pi \times \text{Radius}^2 \text{ (cm)}$ Area (cm ²) = $\pi/4 \times \text{Diameter}^2 \text{ (cm)}$	Area (in ²) = $\pi \times \text{Radius}^2 \text{ (in)}$ Area (in ²) = $\pi/4 \times \text{Diameter}^2 \text{ (in)}$
Cylinder Force	Force (N) = $\frac{\text{Area (cm}^2\text{)} \times \text{Pressure (kPa)}}{10}$	Force (lbf) = Area (in ²) x Pressure (psi)
Cylinder Velocity	Velocity (m/s) = $\frac{\text{Oil Flow (m}^3\text{/min)}}{.006 \times \text{Area (cm}^2\text{)}}$	Velocity (fps) = $\frac{231 \times \text{Oil Flow (gpm)}}{12 \times 60 \times \text{Net Area (in}^2\text{)}}$
Cylinder Volume Capacity	Volume (ℓ) = $\frac{\pi \times \text{Radius}^2 \text{ (cm)} \times \text{Stroke (cm)}}{1000}$	Volume (gal) = $\frac{\pi \times \text{Radius}^2 \text{ (in)} \times \text{Stroke (in)}}{231}$
Cylinder Flow Rate	Flow Rate (ℓ/min) = $\frac{6 \times \text{Velocity (m/s)} \times \text{Area (cm}^2\text{)}}{231}$	Flow Rate (gpm) = $\frac{12 \times 60 \times \text{Velocity (fps)} \times \text{Area (in}^2\text{)}}{231}$
Fluid Motor Torque	Torque (N-m) = $\frac{\text{Pressure (kPa)} \times \text{F.M. Displacement (cm}^3\text{/rev.)}}{2000 \times \pi}$	Torque (in-lb) = $\frac{\text{Pressure (psi)} \times \text{F.M. Displacement (in}^3\text{/rev.)}}{2\pi}$
	Torque (N-m) = $\frac{\text{Power (kW)} \times 9549.3}{\text{rpm}}$	Torque (in-lb) = $\frac{\text{Power (hp)} \times 63025}{\text{rpm}}$
	Torque (N-m) = $\frac{\text{Flow Rate (ℓ/min)} \times \text{Pressure (kPa)}}{6.28 \times \text{rpm}}$	Torque (in-lb) = $\frac{\text{Flow Rate (gpm)} \times \text{Pressure (psi)} \times 36.77}{\text{rpm}}$
Fluid Motor Speed	Speed (rpm) = $\frac{\text{Flow Rate (ℓ/min)}}{1000 \times \text{F. M. Displacement (m}^3\text{/rev.)}}$	Speed (rpm) = $\frac{231 \times \text{Flow Rate (gpm)}}{\text{F.M. Displacement (in}^3\text{/rev.)}}$
Fluid Motor Power	Power (kW) = $\frac{\text{Torque (N-m)} \times \text{Speed (rpm)}}{9549.3}$	Power (hp) = $\frac{\text{Torque (in-lb)} \times \text{Speed (rpm)}}{63025}$
Pump Outlet Flow	Flow (ℓ/min) = $\frac{\text{Speed (rpm)} \times 1000 \times \text{Pump Displacement (m}^3\text{/rev.)}}{231}$	Flow (gpm) = $\frac{\text{Speed (hp)} \times \text{Pump Displacement (in}^3\text{/rev.)}}{231}$
Pump Input Power	Input Power (kW) = $\frac{\text{Flow Rate Output (ℓ/min)} \times \text{Pressure (kPa)}}{60,000 \times \text{Efficiency (overall)}}$	Input Power (hp) = $\frac{\text{Flow Rate Output (gpm)} \times \text{Pressure (psi)}}{1714 \times \text{Efficiency (overall)}}$
Flow Rate Through Piping	Velocity (m/s) = $\frac{\text{Flow Rate Through I.D. (ℓ/min)}}{60,000 \times \text{Internal area (m}^2\text{)}}$	Velocity (fps) = $\frac{.3208 \times \text{Flow Rate Through I.D. (gpm)}}{\text{Internal Area (in}^2\text{)}}$

NOTES

NOTES



GO WITH WHO YOU KNOW

With our vast network of locations around the world, Twin Disc offers you unprecedented sales and service support. We can put engineering and service expertise on location virtually anywhere. We'll work with you on your particular application and product to insure optimum results. We're more than just a name you know, Twin Disc is a name you can trust.



IMPORTANT NOTICE: Twin Disc, Incorporated reminds users of these products that their safe operation depends on use in compliance with engineering information provided in this catalog. Users are also reminded that safe operation depends on proper installation, operation and routine maintenance and inspection under prevailing conditions. It is the responsibility of users (and not Twin Disc, Incorporated) to provide and install guards or safety devices which may be required by recognized safety standards or by the Occupational Safety and Health Act of 1970 and its subsequent provisions.

PUMPDRIVE 4/09 PRINTED IN U.S.A.