



STELLAR® I2621/I2628 TECHNICAL SPECIFICATION GUIDE

12621 12628

Service Crane and TMAX™ Service Bodies



Our People. Our Products.

STELLAR® 12621/12628 TECHNICAL SPECIFICATION GUIDE

■ SPECIFICATION INFORMATION

Crane Rating:	66,000 ft-lbs (9.13 ton-m)
12621 Boom Length:	11' (3.35 m) from CL of Crane
12628 Boom Length:	12' 6" (3.81 m) from CL of Crane
12621 Boom Extension:	
• 1st stage:	Hydraulic 60" (152.4 cm)
• 2nd stage:	Hydraulic 60" (152.4 cm)
12628 Boom Extension:	
• 1st stage:	Hydraulic 96" (243.8 cm)
• 2nd stage:	Hydraulic 96" (243.8 cm)
12621 Max. Reach:	21' (6.40 m) from CL of Crane
12628 Max. Reach:	28' 6" (8.69 m) from CL of Crane
12621 Max. Vertical Lift:	23' (7.01 m)
12628 Max. Vertical Lift:	30' 4" (9.24 m)
Boom Elevation:	-5° to +80°
Stowed Height: (crane only)	35" (88.9 cm)
Mounting Space Required:	20" x 21" (50.8 x 53.3 cm)
Shipping Weight:	2900 lbs (1315 kg)
Controls:	Radio control standard for all functions.
Winch	
• Rope Diameter:	7/16" (1.11 cm)
• Line pull speed:	55 ft/min (16.76 m)
• Max. single part line:	6,000 lbs (2,721 kg)
• Max. double part line:	12,000 lbs (5,443 kg)
Rotation:	400° power (worm gear)
12621 Lifting Capacities:	12,000 lbs @ 5.5' (5,443 kg @ 1.68 m)** 3705 lbs @ 21' (1680 kg @ 6.40 m)**
12628 Lifting Capacities:	12,000 lbs @ 5.5' (5,443 kg @ 1.68 m)** 2745 lbs @ 28' 6" (1245 kg @ 8.69 m)**
Power Supply Required:	PTO & Pump 8 gpm @ 3000 psi (30.3 lpm @ 207 bars)

NOTE: All Stellar cranes meet ANSI B30.5 and OSHA 1910.180 specifications.
Specifications subject to change without notification.

*Crane rating in Boost Mode. Normal crane rating is 66,000 ft-lbs (9.13 ton-m)
**Maximum capacities in Boost Mode.

■ DEFINING CHARACTERISTICS

Stellar® CDT™ Equipped

The Stellar CDT equipped cranes will engage and communicate with the crane operator by using multiple sensory indicators when approaching maximum capacity. This will include the use of colored LED lights and pulsating vibrations. The Stellar CDT control system will also allow the operator to go into a boost mode and operate at nearly 120% of its normal operating capacity for a short period of time.

Remote Control

Stellar Industries was the first U.S. manufacturer to include the state-of-the-art, fully proportional, multi-functional remote control as a standard feature. The radio remote incorporates a variable speed trigger that allows the operators to feather the crane with precise control. Additionally, the radio remote control handle features engine start/stop functions, compressor on/off, engine speed controls, and an emergency shut-off.

Planetary Drive Winch System

To maximize winch speed, Stellar Industries has incorporated a planetary drive winch system with line speeds up to 60-ft/min (18.29 m), giving the 12621/12628 crane over twice the speed of the competition. In addition to speed, the planetary winch also provides mechanical and hydraulic breaks for added security.

Hexagonal Boom Design

Hexagonal booms are stronger and greatly reduce boom flex and side-to-side movement.

Greaseless Bushings

Maintenance free greaseless bushings.

Stainless Steel Pivot Pins

Lower maintenance and extend life.

21' and 28' 6" of Hydraulic Reach

2-stage hydraulic extensions. No manual extensions.

Dual Acting Counter Balance Valves

Integrated into cylinders.

Flip Sheave Optional

Anti Two-Block Device

12621 CAPACITY CHART

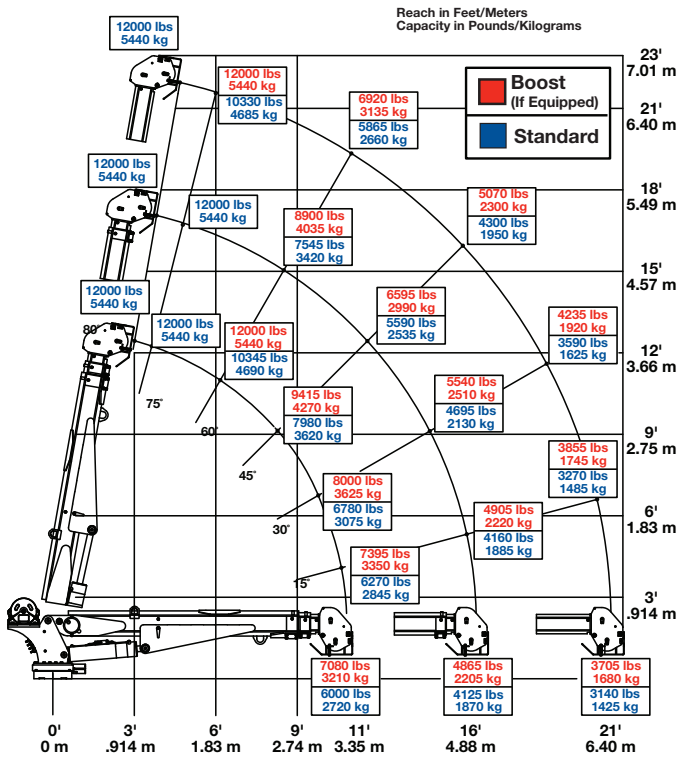

Weight of load handling devices are part of the load lifted and must be deducted from the capacity.

Maximum 1 - part line capacity is 6000 lbs. (2720 kg). For greater loads, use 2 - part line.

12628 CAPACITY CHART

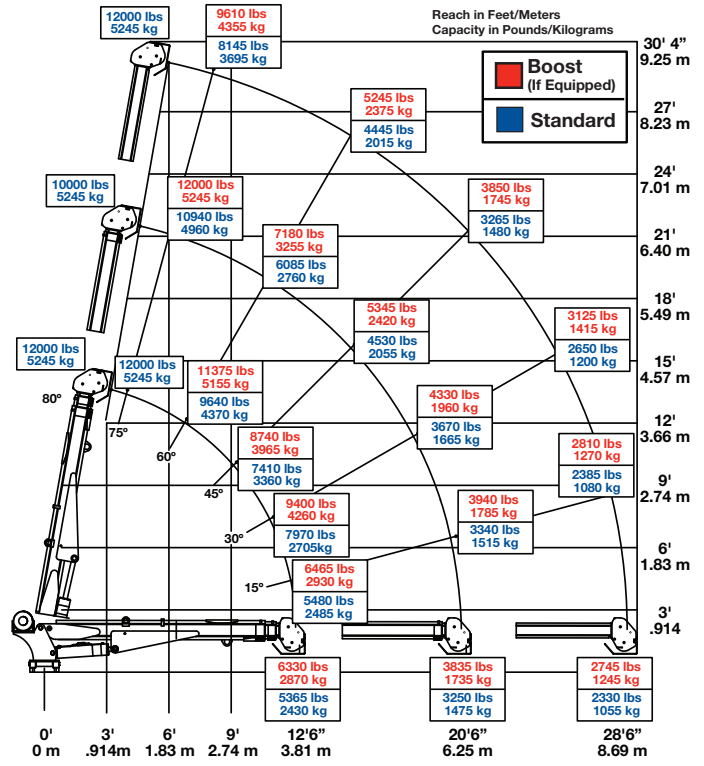

Weight of load handling devices are part of the load lifted and must be deducted from the capacity.

Maximum 1 - part line capacity is 6000 lbs. (2720 kg). For greater loads, use 2 - part line.

ROTATIONAL CLEARANCE

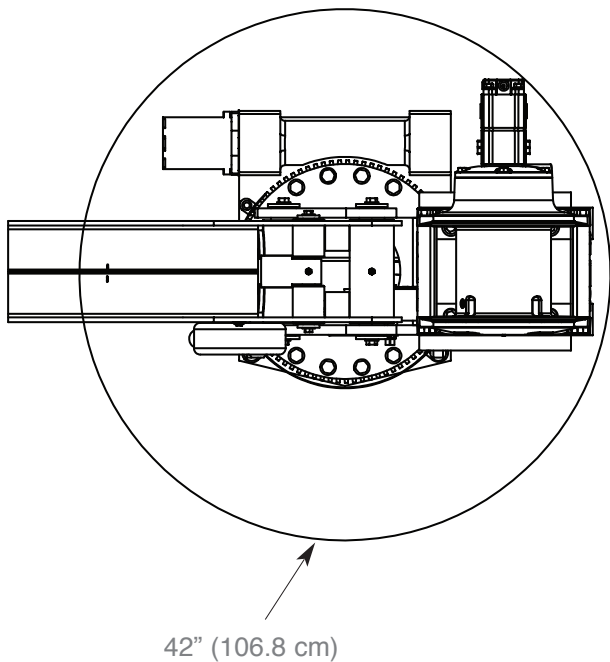

HOLE MOUNTING DETAIL

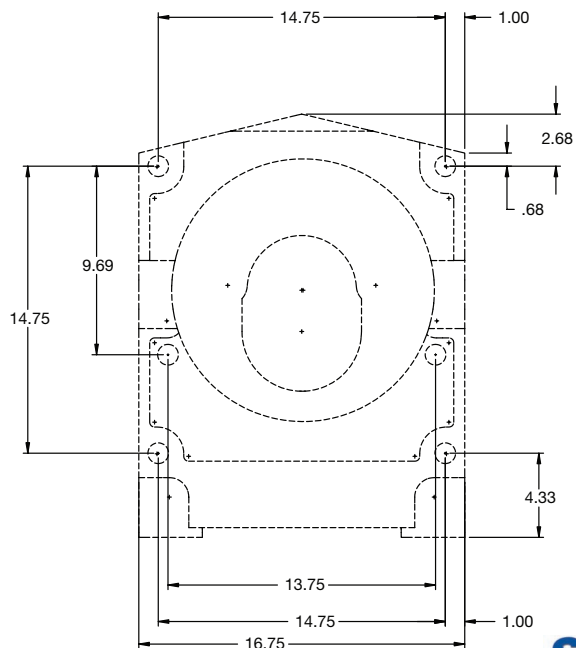

■ **TMAX™ Service Bodies**

TMAX2-11™ Service Body (11' Body)

Applicable Chassis: 25000 GVWR Chassis and up

Crane Models: 7621
7628
9621
9628
10621
10628
12621
12628

Cab to Axle: 84" (213.36 cm)
Body Length Nominal: 133" (337.82 cm)
Body Height: 52" (132.08 cm)
Body Width: 94" (238.76 cm)
Compartment Depth: 22" (55.88 cm)
Floor Width: 50" (127 cm)
Net Weight: 3600 lbs (1632.93 kg)

TMAX2-14™ Service Body (14' Body)

Applicable Chassis: 25000 GVWR Chassis and up

Crane Models: 7621
7628
9621
9628
10621
10628
12621
12628

Cab to Axle: 120" (304.8 cm)
Body Length Nominal: 157" (398.78 cm)
Body Height: 52" (132.08 cm)
Body Width: 94" (238.76 cm)
Compartment Depth: 22" (55.88 cm)
Floor Width: 50" (127 cm)
Net Weight: 4000 lbs (1814.37 kg)

■ **Stellar® Crane Dynamics Technology™ (CDT™)**

A proprietary collection of revolutionary features that includes a two-way communication and feedback feature, a crane boosting feature, and an enhanced safety-monitoring feature.

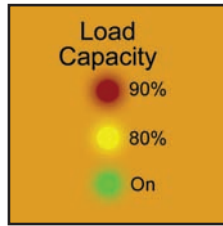

• The new Stellar® CDT™ equipped cranes are the first in the mechanics crane market to offer integral capacity alert into the handheld controller. This system alerts the operator of increasing loads before they reach maximum capacity.

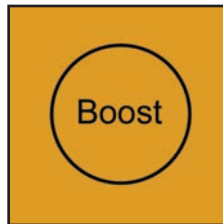

• Through the use of proprietary technology, the Stellar® CDT™ system can also allow operators who exceed standard capacity to productively operate through that situation by increasing crane capacity to 118% of its normal operating capacity for a short period of time.



• The new Stellar® CDT™ equipped cranes feature an enhanced safety system. If a device intended to monitor the capacity of the crane operates incorrectly, the crane will put itself into safe mode. Safe mode will allow the operator to work with the crane at a reduced speed until the safety device is in proper working order.

Your local dealer:



Our People. Our Products.

190 State Street
P.O. Box 169
Garner, IA 50438
Telephone: (641) 923-3741 • (800) 321-3741
Fax: (641) 923-2812
Internet: www.stellarindustries.com
Email: sales@stellarindustries.com

An Employee Owned Company.
Copyright © 2011 Stellar Industries, Inc.