

NOH10N **NOH10NH**

Specifications

**High level
order pickers**
1.0 tonne



Characteristics			Cat Lift Trucks	Cat Lift Trucks
1.01	Manufacturer (abbreviation)		NOH10N	NOH10NH
1.02	Manufacturer's model designation		Battery	Battery
1.03	Power source: (battery, diesel, LP gas, petrol)		Stand-on	Stand-on
1.04	Operator type: pedestrian, (operator)-standing, -seated		1000	1000
1.05	Load capacity	Q (kg)	400/600	400/600
1.06	Load centre distance	c (mm)	210	210/350
1.08	Load wheel axle to fork face (forks lowered)	x (mm)	1490	1490/1525
1.09	Wheelbase	y (mm)		
Weight				
2.01	Truck weight with nominal load & maximum battery weight	kg	4400*	5200*
2.02	Axle loadings with nominal load & maximum battery weight, drive/load side	kg	1050/3350*	1360/3840*
2.03	Axle loadings without load & with maximum battery weight, drive/load side	kg	1450/1950*	2070/2130*
Wheels, Drive Train				
3.01	Tyres: PT=Power Thane, Vul=Vulkollan, drive/load side		Vul/Vul	Vul/Vul
3.02	Tyre dimensions, drive side	(mm)	360x140	360x140
3.03	Tyre dimensions, load side	(mm)	150x100	150x100
3.05	Number of wheels, drive/load side (x=driven)		1x/4	1x/4
3.06	Track width (centre of tyres), drive side	b10 (mm)	867-1270	867-1270
Dimensions				
4.02	Height with mast lowered (see tables)	h1 (mm)	See tables	See tables
4.04	Lift height (see tables)	h3 (mm)	See tables	See tables
4.05	Overall height with mast raised	h4 (mm)	See tables	See tables
4.07	Height to top of overhead guard	h6 (mm)	2260	2260
4.10	Height of load legs	h8 (mm)	151	151
4.11	Supplementary lift	h9 (mm)	750	750
4.14	Platform height, raised	h12 (mm)	See tables	See tables
4.15	Fork height, fully lowered	h13 (mm)	85	85
4.19	Overall length	l1 (mm)	3250	3250
4.20	Length to fork face (includes fork thickness)	l2 (mm)	2095	2095
4.21	Overall width	b1/b2 (mm)	1016/1000-1590	1016/1000-1590
4.22	Fork dimensions (thickness, width, length)	s / e / l (mm)	40/120/1150	40/120/1150
4.25	Outside width over forks (minimum/maximum)	b5 (mm)	540	540
4.27	Width over guide rollers (min.)		1090	1090
4.32	Ground clearance at centre of wheelbase, (forks lowered)	m2 (mm)	45	45
4.33a	Working aisle width (Ast) with 1000 x1200 mm pallets, load crosswise	Ast (mm)	1400	1400
4.34a	Working aisle width (Ast) with 800 x1200 mm pallets, load lengthwise	Ast (mm)	1300	1300
4.35	Turning circle radius	Wa (mm)	1705	1705, 1745
4.41	Transfer aisle width	l8 (mm)	See tables	See tables
Performance				
5.01	Travel speed, with/without load	km/h	9.0/9.0	9.0/9.0
5.02	Lifting speed, with/without load	m/s	0.20/0.30	0.35/0.40
5.03	Lowering speed, with/without load	m/s	0.40/0.45	0.40/0.45
5.10	Service brakes (mechanical/hydraulic/electric/pneumatic)		Electric	Electric
Electric motors				
6.01	Drive motor capacity (60 min. short duty)	kW	3.5	3.5
6.02	Lift motor output at 15% duty factor	kW	5.0	8.5
6.04	Battery voltage/capacity at 5-hour discharge	V/Ah	24/775	48/465, 775
6.05	Battery weight	kg	591	746, 1119
Miscellaneous				
8.01	Type of drive control		Stepless	Stepless
8.04	Noise level, mean value at operator's ear (EN 12053)	dB(A)	-	-

* Platform height 6100mm



NOH10N/NH

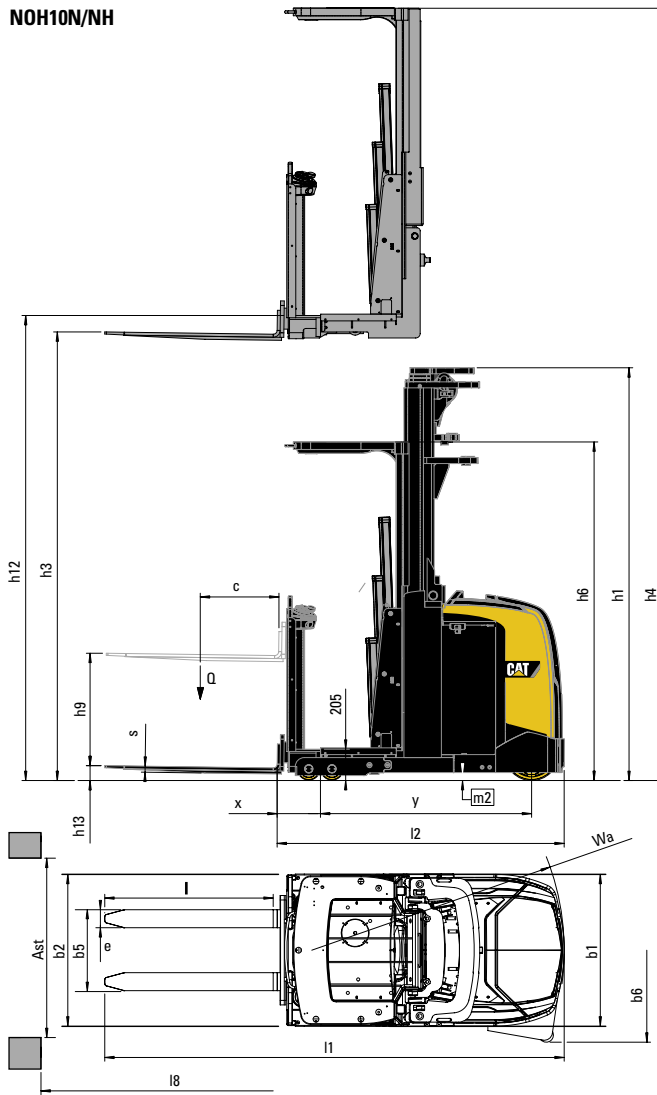

- Ast = Working aisle width
- $Ast = Wa + \sqrt{(l6 + x)^2 + (b12 / 2)^2} + a$
- Wa = Turning radius
- l6 = Pallet length
- x = Load wheel axle to fork face
- b1/b2 = Overall width
- a = Safety clearance = 2 x 100 mm

Lower Cost of Ownership

- A market leading 11.5 meter picking height and fast lowering and travel speeds improve throughput and reduce cycle times, contributing directly to bottom line profits. The NOH10N/NH models are designed for high stability and feature excellent residual capacities.
- AC power gives these trucks excellent levels of performance with minimal maintenance requirements. These trucks are available in 24V (NOH10N) or high performance 48V (NOH10NH) configurations.
- A variety of optional features and programmable performance allows for customization to each users' requirements, ensuring maximum return from your investment.
- Low service costs due to long service interval, reliable, tested components, easy access, quick fault finding, good access to major components and AC technology.

Unmatched Productivity

- The lifting mechanism of the Ergolift is placed below the cabin floor giving the operator very good access to the load from the cabin.
- High picking height and the truck's suitability for use in very narrow aisles permits efficient use of warehouse space.
- Standard lift-height preselector allows a more convenient picking operation.
- Highest lifting speed in the market (NOH10NH).
- PoweRamic mast gives excellent visibility particularly when the truck is travelling with the forks trailing.
- Triplex mast available for applications requiring a low overall height.
- Three different chassis widths and 4 different cabin widths available to allow the truck to be adapted to its application.
- PIN code startup combined with driver specific settings as standard.
- Small turning radius allows for a small transfer aisle.
- AC lifting & driving motors (NOH10NH).
- Up to 775 Ah battery capacity for long shifts.
- Battery rollers included as standard making battery changing a quick and effortless process.

Safety and Ergonomics

- Split control unit provides good pallet access, and reduces the risk of the operator accidentally touching the controls when leaning outside the cabin. The controls can be placed mast or fork side.
- Redesigned ergonomic controls, including a joystick and a inductive hand detector for safe operation inside the aisle.
- Smoothly shaped lightweight aluminium side gates for comfortable orderpicking and a comfortable, height adjustable backrest.
- Specially designed floormat prevents slipping.
- Double load wheels for extra stability and low step in height of 205 mm.

Options

- Wire guidance and two versions of rail guidance (40 mm and 100 mm height) possible.
- Automatic braking at the end of the aisle.
- Special design covers.
- Key switch to replace the PIN code.
- Working lights and cabin lights.
- Various fork lengths and widths.
- Liftstop with override function.
- Automatic stop in case of obstacles in the aisle.

Cat® Lift Trucks.

Your partner in materials handling.

NOH10N					
Mast Type	h12	h1	h4	h3+h9+h13	h12+1500
	mm	mm	mm	mm	mm
D	3200	2237	5250	3830	4700
	3500	2417	5550	4130	5000
	4200	2757	6250	4830	5700
	4800	3032	6850	5430	6300
	5200	3237	7250	5830	6700
	6200	3737	8250	6830	7700
T	4100	2237	6150	4730	5600
	4600	2237	6650	5230	6100
	5100	2417	7150	5730	6600
	6100	2757	8150	6730	7600
	7000	3032	9050	7630	8500
	7700	3437	9750	8330	9200
	8100	3577	10150	8730	9600

Mast Performance and Capacity

D	Duplex PoweRamic mast
T	Triplex PoweRamic mast
h1	Lowered mast height
h4	Raised mast height
h12	Platform height
h3+h9+h13	Maximum fork height
h12+1500	Order picking height

NOH10NH					
Mast Type	h12	h1	h4	h3+h9+h13	h12+1500
	mm	mm	mm	mm	mm
D	3200	2237	5250	3830	4700
	3500	2417	5550	4130	5000
	4200	2757	6250	4830	5700
	4800	3032	6850	5430	6300
	5200	3237	7250	5830	6700
	6200	3737	8250	6830	7700
T	4100	2237	6150	4730	5600
	4600	2237	6650	5230	6100
	5100	2417	7150	5730	6600
	6100	2757	8150	6730	7600
	7000	3032	9050	7630	8500
	7700	3437	9750	8330	9200
	8100	3577	10150	8730	9600
	8600	3737	10650	9230	10100
	9300	3997	11350	9930	10800
	10000	4207	12050	10630	11500

MINIMUM TRANSFER AISLE WIDTH*			
	NOH10N		NOH10NH
	775 Ah	465 Ah	775 Ah
1200 x 1000 cross wise	3256	3256	3422
1200 x 800 cross wise	3080	3080	3242
1200 x 800 length wise	3371	3371	3546

* Including 200 mm clearance and 1000 mm or 1150 mm forks

catliftruck@mcf.nl
www.catliftruck.com

WESC1139(05/09)ok
Copyright ©2009, MCFE. All rights reserved.
CATERPILLAR, CAT, their respective logos,
'Caterpillar yellow' and the 'POWER EDGE' trade dress,
as well as corporate and product identity used herein,
are trademarks of Caterpillar and may not be used
without permission.
Printed in The Netherlands

NOTE: Performance specifications may vary depending on standard manufacturing tolerances, vehicle condition, types of tyres, floor or surface conditions, applications, or operating environment. Trucks may be shown with non-standard options. Specific performance requirements and locally available configurations should be discussed with your Cat lift trucks Dealer. Cat Lift Trucks follows a policy of continual product improvement. For this reason, some materials, options and specifications could change without notice.

CAT® Lift Trucks